



International Space Agency, ISA
International Space Administration
Founded In 1986 -&- Incorporated In 1990
Presently Seeking International Treaty -&- Charter Status

1986 / 2017 - PROPOSAL

**INTERNATIONAL SPACE AGENCY ORGANIZATION
VISION, CONCEPT, THESIS, STRUCTURE & MISSION**

**Special Thanks To: Dr. Frank Rhoads & Dr. Norman Scott
And To: Cornell University In Ithaca, New York State
Birth Place Of The International Space Agency Endeavor**



International Space Agency , I.S.A.
International Space Administration
 Founded In 1986 -&- Incorporated In 1990
 Presently Seeking International Treaty -and- Charter Status

1986 / 2017 - PROPOSAL
INTERNATIONAL SPACE
AGENCY ORGANIZATION
VISION, CONCEPT, THESIS
STRUCTURE -&- MISSION

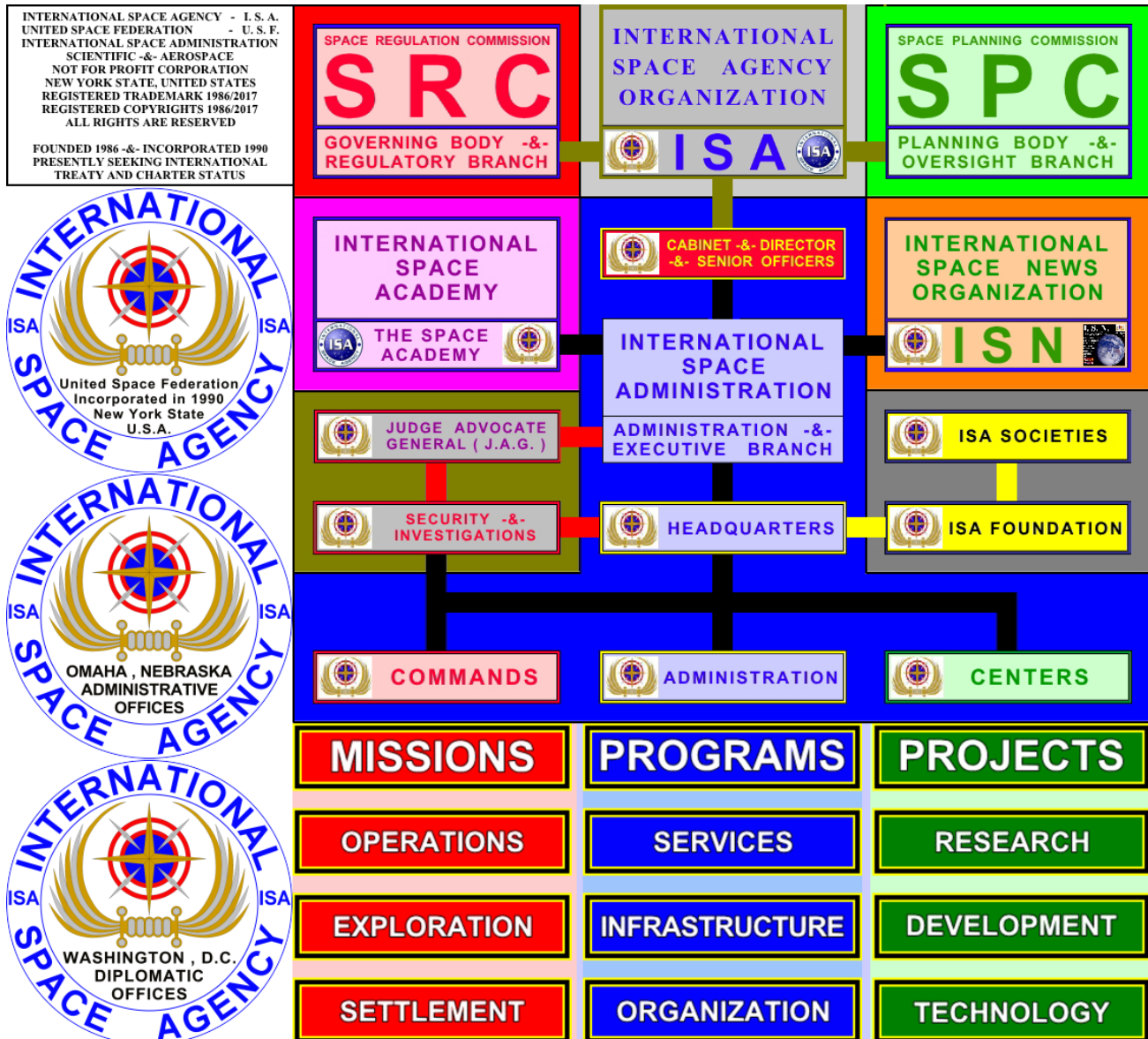

A. General Information

Project Title:	International Space Agency: (Phase 1 - Corporation) / (Phase 2 - Treaty & Charter Organization)
Brief Project Description:	To: Promote, Create, Develop, Organize, Operate, and Fund the International Space Agency Organization into: FIRSTLY , in planned “Phase 1” as a “ Non-Profit Corporation in the United States ”, and then after it sufficiently matures over time, the International Space Agency will then, SECONDLY , be advanced into “Phase 2” as a “ Joint / International / Multi-National - Treaty and Fully Internationally Chartered and Recognized Organization ”. It is to be noted here that: “Phase 1 Has Already Been Achieved In 1990”. The body of extensive and dedicated work achieved to date, in 2017, is in the thousands of pages, and many hundreds of Diplomatic, Private, Public meetings
Prepared By:	Admiral, Rick R. Dobson, Jr. - United States - Founder, Chairman & CEO, International Space Agency
Date:	<ol style="list-style-type: none"> 1) 21 August, 1986 - Founded By Admiral, Rick R. Dobson, Jr. in: 1986 “Circa” (Trademark & Copyright 1986) 2) 17 October, 1987 - International Space Agency “Organization” - Initial Vision, Concept & Thesis Completed 3) 19 June, 1990 - Non-Profit Scientific & Aerospace Corporation, New York State, United States “United Space Federation” 4) 22 May, 1992 - First International Meeting was held at the: Carnegie Endowment For International Peace, Washington, D.C. 5) 1992 -&- 2002 - International Diplomatic, Meetings, Dispatch’s, Presentations – Attendance At: “World Space Conference” 6) 1990 to 2017 - International Space Agency is: “Presently Seeking International Treaty & Charter Status” 7) International Space Agency 1990 Proposal “Globally ResubmittedIn2017” / “1986 To 2017 - 30+ Years Of History” <p>Note: All Activities and Endeavors of the International Space Agency are: “Perpetual -&- On Going Since 1986”</p>

B. Project Objective:

PURPOSE: International Space Agency is a Scientific & Aerospace “SPACE” Organization, which has as its Vision & Core Focus a “Global/International/Multi-National” Perspective & Mission. Its Primary Purpose, Focus, Mission Directives are to:

- 1) Act as a Central Diplomatic & Neutral Unifying Conduit and Enabler Organization between “National Entities” and “National Space Agencies” for Co-Operative/Joint International “Non-Military” Civil Space Activities “**Outside The National Domain & Capability**”.

For Example: Extensive Infrastructure of Scope & Scale & Longevity, such as: International Programs, Missions, Stations, Bases, and Human Settlement “In/To/On” Earths Orbit, Earths Moon “Luna”, Mars, and though out Earths Solar System, “and Beyond”.

It Must Be Noted Here For The Official Public Record: The International Space Agency does **NOT!** seek to eliminate “**National Space Agencies**” or directly compete in “**For Profit**” Aerospace, Commercial, Technology Sectors. The International Space Agency does **NOT!** seek to become a “**World Space Agency**” or in anyway be “**Part Of / Or Under The Control Of**” the United Nations.

- 2) Act as a permanent “Perpetual” and dedicated international space organization and expertise asset “**Outside The National Domain & Capability**”; which can provide central joint/cooperative/multi-National: Diplomacy & Treaties, Leadership & Administration, Education & Personnel Training, Research & Development, Quality Control & Safety, Technology Creation & Deployment, Exploration & Resource Acquisition, Programs & Projects, , Extra-Earth Human Planet/Moon Facilities & Settlements, Orbital Launch & Return Infrastructure, Orbital/Space Stations & Facilities, Ships & Missions, Remote Sensing Satellites & Robotic Technologies, Solar/Extra-Solar Communications & Navigations Networks, Central Data-Storage & Retrieval Facility, Radio & Visual Astronomy Networks, Space Search & Rescue, Space News “Journalism” and public informational seminars, Asteroid/Comet/SpaceWeather Monitoring & Protocols, Classified National Military Joint Hazards Warning & Launch Warning Protocols, Space Debris Mitigation & Protocols, Patent & Trademark Protocols, Corporation & Licensing Protocols, Trade & Tourism Protocols, Space Law & Judicial Protocols, Astrobiology/Exobiology/Biology Research & Protocols, Global Citizen Involvement through the “*International ISA Foundation*” & “*National-ISA Societies*”. Global Institutions like the European Space Agency, Intelsat, Airbus Industries, and International Red Cross are Organizational Models on which the Conceptual Work & Thesis of the International Space Agency was greatly influenced by.
- 3) Act as a central “Earth Surface to Earth Orbit” / “Planet/Moon Orbital & Inter-Planetary/Moon” / “Solar & Extra-Solar” transportation grid and established neutral Joint/International/Multi-National infrastructure and network of Peaceful Human Activities in Earths Orbit, Earths Solar System, and Beyond. (ie: Joint/International/Multi-National Space Highway & Infrastructure System – Based on a Fee System and Pay as you Go Strategy & Philosophy to finance the design, building, operation, and maintenance of this state of the art global space infrastructure and asset, which would be managed, operated, and maintained by the International Space Agency on the behalf of its treaty partners, contributors, and end users) (ISA will also act like a Stock Market and Trade & Jobs Creation Conduit)
- 4) Act as a central depository, conduit, and cross roads for the Cultures, Knowledge, Science, Arts, History, of the Peoples of Earth.
- 5) In the “**Hypothetical**” case of an impending disastrous impact of Earth of any dangerous space object or debris, such as a large “**Asteroid or Comet**”. The International Space Agency would act as a rapid enabler & conduit to National Military Organizations with the means and abilities to project large scale force “Nuclear Weapons” to divert the course of any such dangerous Earth impactors away from Earth, render them less dangerous, or to destroy them entirely. Also, in the “**Hypothetical**” case of contact in Space, “**On The Space Frontier**”, between Humans of Earth and “**Beings Not Of Earth**”, the International Space Agency will uniquely possess the specific and specialized expertise, personnel, training, and mindset to best act on the behalf of the Peoples of Earth, either Confidentially, or Openly, as the reality of any such scenario may demand; and to interact peacefully with any such Beings/Entities should they be, likewise peaceful. However, if any such Beings/Entities prove to be hostile, the International Space Agency would act as a unified conduit between National Military Organizations of Earth in Defending Earth and its Peoples from any overtly hostile beings or scenario. Both “**Hypothetical Scenarios**” would most likely be “**Highly Classified**” Extremely Limited in Public Domains, and very narrow and specific in the protocols and interaction with, and between, the International Space Agency and National Military Organizations and Governments of Earth. It is therefore, essential, for the International Space Agency to actively engage these topics.

CAPABILITY: Areas of Operations, Programs, Missions Authority: Treaty & Diplomatic, Organization & Administration, Leadership & Personnel, Operations & Missions, Projects & Programs, Research & Development, Education & Training, Foundation & Societies

BENEFITS: International Space Agency will Dramatically Reduce Costs & Obligations to: Governments & NGO’s Globally, due to Coordinated, Unified, and Shared - Financial, Material, Research & Development, Program, Organizational, Expertise, Training, Personnel Resources & Assets for Peaceful Human Space Activities & Endeavors - “**Outside The National Domain & Capability**”.

FUNDING: Costs for all International Space Agency: Infrastructure, Administration, Operations will be obtained primarily through a pay for use strategy “**Toll or Fee**” by all end users, whether they be National Governments or Non-Governmental Entities, Organizations, or Persons; and “**Augmented**” by approved Multi-National & Joint Programs Participation, Government & Private Grants, Private Philanthropy. A proposed initial amount of (\$ 7 Million) U.S. Dollars is sought for “**Phase 2**” ISA start up funding.





FROM THE STARS WE CAME
TO THE STARS WE RETURN
~ IN PEACE ~
FOR ALL
~ MANKIND ~

THE KNOWN AND CREATED
UNIVERSE

AND BEYOND

9
INTERSTELLAR
SPACE EXPLORATION
(I.S.E.) PROGRAM

INTERSTELLAR
SPACE

8
SOLAR SYSTEM
EXPLORATION
(S.S.E.) PROGRAM

7
INTERNATIONAL
MARS EXPLORATION
(I.M.E.) PROGRAM

MARS

5
INTERNATIONAL
PLANETARY / MOON
LAUNCHER / LANDER
(I.P.M.L.L.) PROGRAM

4
INTERNATIONAL
SOLAR CRUISER
(I.S.C.) PROGRAM

6
INTERNATIONAL
LUNA EXPLORATION
(I.L.E.) PROGRAM

LUNA

SEVEN
GATEWAY
PROGRAMS
LUNA / MARS
EARTH
I.S.O.C.
~7~

EARTH ORBIT

3
INTERNATIONAL
SPACE STATION
(I.S.S.) PROGRAM

2
INTERNATIONAL EARTH
ORBITAL INFRASTRUCTURE
(I.E.O.I.) PROGRAM

1
INTERNATIONAL
SPACE PLANE
(I.S.P.) PROGRAM

EARTH

INTERNATIONAL SPACE OPERATIONS CENTER
I.S.O.C. - SEVEN "7" KEY GATEWAY PROGRAMS

**E.L.M.A.
EARTH / LUNA / MARS
AND BEYOND**

VISION & MISSION DIRECTIVES

E. L. M. A. - EARTH / LUNA / MARS / AND BEYOND

**INTERNATIONAL SPACE EXPLORATION PROGRAM
SEVEN "7" KEY GATEWAY PROGRAMS**

**INTERNATIONAL SPACE OPERATIONS CENTER
I. S. O. C. - 1, 2, 3, 4, 5, 6, 7**



INTERNATIONAL SPACE OPERATIONS CENTER
 I. S. O. C. - SEVEN "7" KEY GATEWAY PROGRAMS

E.L.M.A.
EARTH / LUNA / MARS
AND BEYOND



THE KNOWN AND CREATED
UNIVERSE

FUTURE MANNED & ROBOTIC MISSIONS

INTERSTELLAR SPACE

INTERSTELLAR SPACE EXPLORATION (I.S.E.) PROGRAM

AND BEYOND

SOLAR SYSTEM EXPLORATION (S.S.E.) PROGRAM

INTERNATIONAL MARS EXPLORATION (I.M.E.) PROGRAM

INTERNATIONAL PLANETARY / MOON LAUNCHER / LANDER (I.P.M.L.L.) PROGRAM

HAB MODULES
INCHERS
LANDERS

MARS

SURFACE ACTIVITIES CONSTRUCTION EQUIPMENT & ROVERS & AIRCRAFT & BASES

ADVANCED HUMAN SETTLEMENTS
INDUSTRY / COMMERCE / FARMS

MANNED & ROBOTIC

INTERNATIONAL SOLAR CRUISER (I.S.C.) PROGRAM

INTERNATIONAL LUNA EXPLORATION (I.L.E.) PROGRAM

HAB MODULES
INCHERS
LANDERS

LUNA

SURFACE ACTIVITIES CONSTRUCTION EQUIPMENT & ROVERS & BASES

LIMITED HUMAN OUTPOSTS

ARTIFICIAL GRAVITY STATION

EARTH ORBIT

INTERNATIONAL SPACE STATION (I.S.S.) PROGRAM

ZERO GRAVITY STATION

INTERNATIONAL EARTH ORBITAL INFRASTRUCTURE (I.E.O.I.) PROGRAM

INTERNATIONAL SPACE PLANE (I.S.P.) PROGRAM

EARTH

INTERNATIONAL SPACE OPERATIONS CENTER
I.S.O.C. - SEVEN "7" KEY GATEWAY PROGRAMS

**E.L.M.A.
EARTH / LUNA / MARS
AND BEYOND**

TECHNOLOGY & PROGRAMS

- 1 - INTERNATIONAL EARTH ORBITAL INFRASTRUCTURE (I.E.O.I.) PROGRAM
- 2 - INTERNATIONAL SPACE PLANE (I.S.P.) PROGRAM
- 3 - INTERNATIONAL SPACE STATION (I.S.S.) PROGRAM
- 4 - INTERNATIONAL SOLAR CRUISER (I.S.C.) PROGRAM
- 5 - INTERNATIONAL PLANETARY/MOON - LAUNCHER/LANDER (I.P.M.L.L.) PROGRAM
- 6 - INTERNATIONAL LUNA EXPLORATION (I.L.E.) PROGRAM
- 7 - INTERNATIONAL MARS EXPLORATION (I.M.E.) PROGRAM

International Space Agency – Phase 2

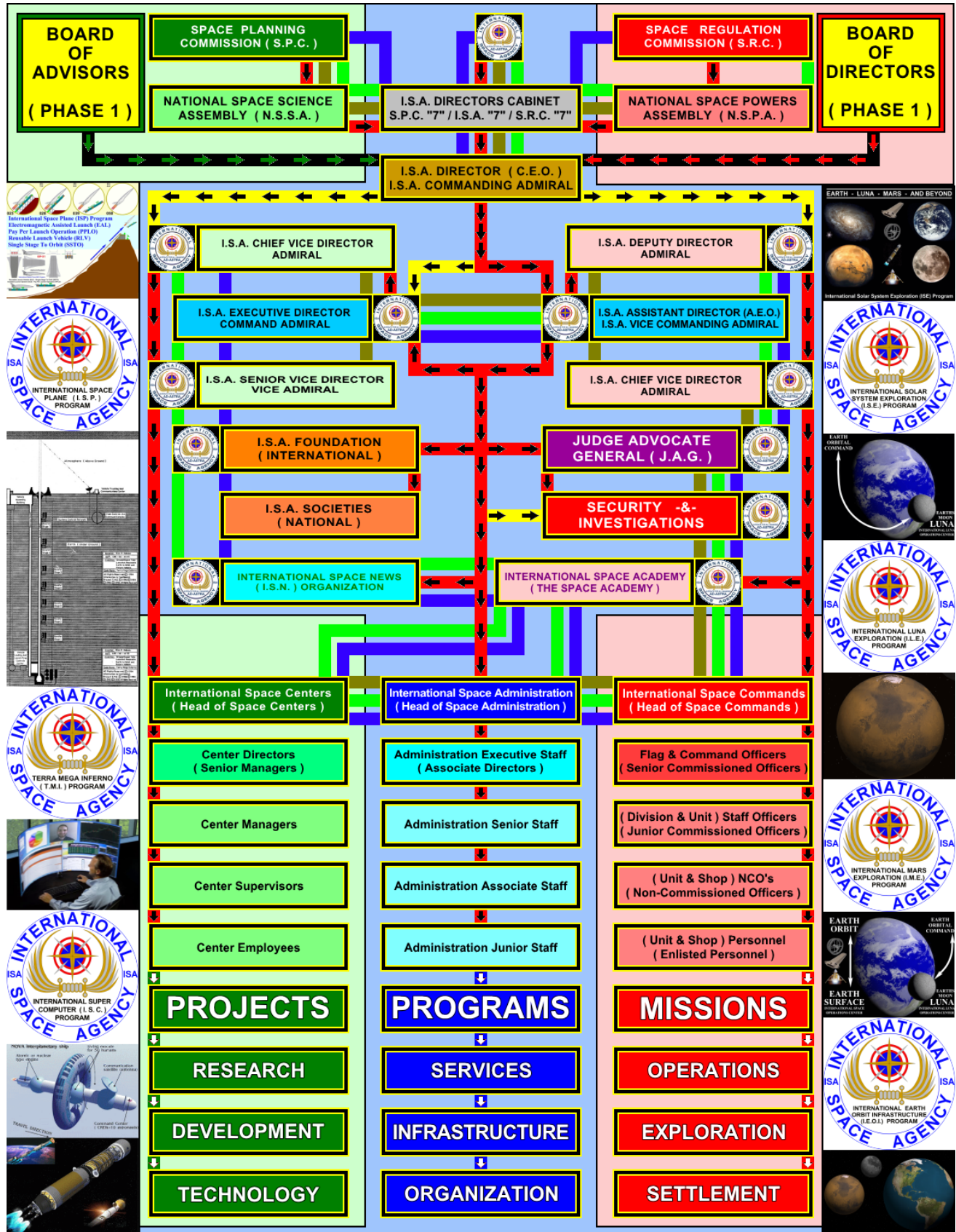

International Space Agency, I.S.A.: Name, Public Identity, Logo, Emblem: Are: U.S.A. Registered®: Trademark™ -&- Copyrights©, 1986-2017, All Rights Reserved
 United Space Federation, U.S.F.: Scientific -&- Aerospace / Research -&- Development / Non-Profit Corporation / Incorporated 1990 / New York State / United States

Director “Chief Executive Officer” (CEO) of the **International Space Agency, I.S.A. / International Space Administration**
 ISA Board of Directors Voting Rights (**13th Board Member**), Over All Veto Rights, First Over All **ISA Control & Command (*ISA Director)**
ISA Commanding Admiral (0-12) (5 Stars Gold) – “Appointed by the Board of Directors” / “Term Perpetual”
Assistant Director “Assistant Executive Officer” (AEO) of the **International Space Agency, I.S.A. / International Space Administration**
 ISA Board of Directors Voting Rights, Second Over All ISA Control & Command (****Chairperson, Board of Directors**)
ISA Vice Commanding Admiral (0-11) (4 Stars Gold) – “Appointed by the Board of Advisors” / “Term Perpetual”
Executive Director of the **International Space Agency, I.S.A. / International Space Administration**
 ISA Board of Directors Voting Rights, Third Over All ISA Control & Command (***) **Vice Chairperson, Board of Directors**)
Command Admiral (0-10) (3 Stars Gold) – “Appointed by the ISA Officers Rank & File By Majority Vote Annually” / “Term Perpetual”
Deputy Director of the **International Space Agency, I.S.A. / International Space Administration**
 ISA Board of Directors Voting Rights, Fourth Over All ISA Control & Command (******Secretary, Board of Directors**)
Admiral (0-9) (3 Silver Stars) – “Appointed by ISA Non-Officers/Staff Rank & File By Majority Vote Annually” / “Term Perpetual”
Chief Vice Director of the **International Space Agency, I.S.A. / International Space Administration**
 ISA Board of Advisors No Voting Rights, Fifth Over All ISA Control & Command (*******Chairman, Board of Advisors**)
Admiral (0-9) (3 Silver Stars) – “Appointed by SRC By Majority Vote Annually” / “Term Perpetual”
Senior Vice Director of the **International Space Agency, I.S.A. / International Space Administration**
 ISA Board of Advisors No Voting Rights, Sixth Over All ISA Control & Command (*******Vice Chairman, Board of Advisors**)
Vice Admiral (0-8) (2 Silver Stars) – “Appointed by SPC By Majority Vote Annually” / “Term Perpetual”
Junior Vice Director of the **International Space Agency, I.S.A. / International Space Administration**
 ISA Board of Advisors No Voting Rights, Seventh Over All ISA Control & Command (*******Secretary, Board of Advisors**)
Rear Admiral (0-7) (1 Silver Star) – “Appointed by ISA Director” / “Term Perpetual”

Board of Directors - “Full Voting Rights” - International Space Agency (I.S.A.) - (CORPORATION)

- 1) ***Chairperson - ISA Vice Commanding Admiral** (0-11) (4 Stars Gold) - **ISA Assistant Director** “Assistant Executive Officer” (DAO)
- 2) ****Vice Chairperson - Command Admiral** (0-10) (3 Stars Gold) - Chief Administrative Officer (CAO)
- 3) *****Secretary - Admiral** (0-9) (3 Stars Silver) - Chief of Records (COR)
- 4) **Commanding Officer Of The International Space Academy - Admiral** (0-9) (3 Stars Silver)
- 5) **Chief Legal Officer (CLO) “External” -&- Judge Advocate General “Internal” - Admiral** (0-9) (3 Stars Silver)
- 6) **Treasurer – Vice Admiral** (0-8) (2 Stars Silver) - Chief Financial Officer (CFO)
- 7) **Chief of Personnel -&- Facilities Security – Vice Admiral** (0-8) (2 Stars Silver)
- 8) **Chief of Data & Electronic Communications – Vice Admiral** (0-8) (2 Stars Silver)
- 9) **Chief of Programs -&- Projects – Rear Admiral** (0-7) (1 Silver Star)
- 10) **Chief of Commands -&- Missions - Rear Admiral** (0-7) (1 Silver Star)
- 11) **Chief of Centers -&- Facilities - Rear Admiral** (0-7) (1 Silver Star)
- 12) **Editor in Chief of International Space News - Captain** (0-6) (Silver Crest)

Board of Advisors - “No Voting Rights Externally from Board of Advisors” - International Space Agency (ISA) CORPORATION

- 1) ******Chairperson - Admiral** (0-9) (3 Stars Silver)
- 2) *******Vice Chairperson - Vice Admiral** (0-8) (2 Stars Silver)
- 3) *******Secretary - Rear Admiral** (0-7) (1 Silver Star)
- 4) **Director of Government Space Affairs Office – Captain** (0-6) (Silver Eagle)
- 5) **Director of Commercial Space Affairs Office – Commander** (0-5) (Silver Crest)
- 6) **Director of Academic & Scientific Affairs Office – Lieutenant Commander** (0-4) (Gold Crest)
- 7) **Director of Space Institutions, NGO’s, Foundations, Societies Affairs Office – Lieutenant** (0-3) (Silver Twin Bars)
- 8) **Director of ISA Foundation & Societies – Lieutenant** (0-3) (Silver Twin Bars)
- 9) **Director of Public Affairs – Lieutenant** (0-3) (Silver Twin Bars)
- 10) **Director of Board of Advisors Outreach & Recruitment – Lieutenant** (0-3) (Silver Twin Bars)
- 11) **Director of Board of Advisors Internal Communications & Affairs – Lieutenant** (0-3) (Silver Twin Bars)
- 12) **Members of the ISA Board of Advisors**
 - A) **Master Member** – Official Representative of a Government, Corporation, or Institute. - **Lieutenant Junior Grade** (0-2) (Silver Bar)
 - B) **Senior Member** – Recognized By ISA Administration as Critical Guild or Skill & Service More Than 4 Years – **Ensign** (0-1) (Gold Bar)
 - C) **Full Member** – Approved Voluntary Service of more than 4 years – **Master Chief** (E-9)
 - D) **Junior Member** - Approved Voluntary Service of less than 4 years, but more than 30 days - **Senior Chief** (E-8)
 - E) **Candidate Member** - Approved Voluntary Service of less than 30 days - **Chief** (E-7) or **Petty Officer 1st Class** (E6)

INTERNATIONAL SPACE AGENCY ORGANIZATION- (INTERNATIONAL SPACE COMMANDS) RANKS:

Commissioned Officers: Commanding Admiral (0-12), Vice Commanding Admiral (0-11), Command Admiral (0-10), Admiral (0-9), Vice Admiral (0-8), Rear Admiral (0-7), Captain (0-6), Lieutenant Commander (0-5), Commander (0-4), Lieutenant (0-3), Lieutenant Junior Grade (0-2), Ensign (0-1), Acting Ensign or Command Cadet (0-AE / 0-CC)

Warrant Officers: Master Warrant Officer (W-4/0-2) Senior Warrant Officer (W-3/0-1) Chief Warrant Officer (W-2/E-9) Warrant Officer (W-1/E-8)

Non-Commissioned Officers: Master Chief of ISA (E-12), Master Chief of Commands (E-11), Command Master Chief (E-10), Master Chief (E-9), Senior Chief (E-8), Chief (E-7), Petty Officer 1st Class (E-6), Petty Officer 2nd Class (E-5), Petty Officer 3rd Class (E-4)

Enlisted Ranks: Crewman (E-3), Crewman Apprentice (E-2), Crewman Recruit (E-1), Recruit in Training (E-0)

INTERNATIONAL SPACE ACADEMY “The Space Academy:

(4YR) Officer Cadets: Command Cadet (Yr 4), Master Cadet (Yr 4), Senior Cadet (Yr 3), Chief Cadet (Yr 2), Cadet Recruit (Yr 1)

(2YR) NCO Cadets: Petty Officer 1st Class (Yr1-Mth6+), Petty Officer 2nd Class (Yr1+), Petty Officer 3rd Class (Mth6+), Crewman (Mth0+)

(1YR) Enlisted Recruits: Crewman (Mth 9+), Crewman Apprentice (Mth 6+), Crewman Recruit (Mth 3+), Recruit in Training (Mth 0+)

INTERNATIONAL SPACE AGENCY (ISA) – PHASE 2 – LEADERSHIP STRUCTURE

International Space Agency (ISA) – Organizational: Branches / Divisions / Departments

Space Regulations Commission (SRC) – Governing & Regulatory Branch

Nations “Governmental” - Agencies, Organizations, Institutes, and Diplomatic Representatives which are Signatory Members to the International Space Agency Charter, or Treaty, or Contracted

Space Planning Commission (SPC) – Planning & Oversight Branch

Non-Governmental” - Organizations, Corporations, Institutes, Foundations, Societies and Persons which are Signatory Members to the International Space Agency Charter and being under Contract

International Space Administration – Executive & Administration Branch

- 1) **International Space Administration - Headquarters - ISA Administration “Executive” Branch**
 - A - Executive Leadership (ISA Director & ISA Directors Cabinet)
 - B - Judge Advocate General - ISA Division
 - C - Security Office - ISA Division
 - D - International Space Academy “The Space Academy” - ISA Division
 - E - International Space News - ISA Division
 - F - International Space Agency Foundation & Societies - ISA Division
 - G - Commissions, Committees, Working Groups
 - H - Programs / Administration – Diplomatic & Executive Structure “Elected & Appointed Organizational Structure”
- 2) **International Space Commands - Headquarters - ISA Commands Branch**
 - A - Planet / Moon – Orbital Space Colonies / Artificial Gravity “Spun” Orbital Stations / “0” Gravity Orbital Stations
 - B - Planet / Moon / Asteroid – Surface / Sub-Surface - Settlements / Outposts / Bases / Facilities / Operations / Missions
 - C - Planet / Moon / Asteroid – Launchers / Landers / Probes / Aircraft / Surface Vehicles / Civil Engineering Equipment
 - D - Interplanetary Transits / Deep Space – Solar Cruisers / “Crewed” Ships / “Cargo” Ships / Probes / Specialized Craft
 - E - Missions / Commands – Maritime Chain Of Command “United States Navy Ranking & Organizational Structure”¹
- 3) **International Space Centers - Headquarters - ISA Centers Branch**
 - A - International Space Operations Center (I. S. O. C.) - ISA Division
 - B - International Super Computer Center (I. S. C. C.) - ISA Division
 - C - International Advanced Space Technology Research & Development Center (I.A.S.T.R.D.C.) - ISA Division “Group”
 - International Advanced Space Propulsion Division (I. A. S. P. D.)
 - International Advanced Space Power Division (I. A. S. P. D)
 - International Advanced Space Structures Division (I. A. S. S. D)
 - International Advanced Planet & Moon Structures Division (I. A. P. M. S. D)
 - International Advanced Space Life Support Systems Division (I. A. S. L. S. S. D)
 - International Advanced Space Craft Division (I. A. S. C. D)
 - * Planet/Moon – Orbital Transit / Interplanetary – Solar Cruisers Department
 - * Planet/Moon – Orbital Transit / Interplanetary – “Crewed” & “Cargo” Ships Department
 - * Planet/Moon – Orbital Transit / Interplanetary – “Robotic” Probes / Satellites Department
 - * Planetary/Moon/Asteroid – “Surface to Orbit” Launchers Department
 - * Planetary/Moon/Asteroid – “Orbit to Surface” Landers Department
 - * Planetary/Moon/Asteroid – “Surface” Vehicles Department
 - * Planetary/Moon/Asteroid – “Atmospheric” Vehicles “Aircraft/Balloons” Department
 - * Planetary/Moon/Asteroid – Surface Civil Engineering Equipment Department
 - D - International Space/Planet/Moon Sciences & Astrophysics Research Center (I. S. P. M. S. A. R. C.) - ISA Division
 - E - International Astronomical Observation Research Center (I. A. O. M. R. C.) – ISA Division “Group”
 - * Deep Space – Universe/Dark Matter/Galaxies/Nebulas/ExoSolar Systems/ExoPlanets/ExoMoons – Research Center
 - * Optical Astronomy Department
 - * Radio / Inferred / X-Ray / Cosmic Radiation Astronomy Department
 - * Space Weather Monitoring & Warning & Research Department
 - * Asteroid/Comet Monitoring & Warning & Research Department
 - F - International Human Biology & Medical Services & Astrobiology/Exobiology/SETI Research Center - ISA Division
 - G - International Space Resources Exploration/Exploitation & Industrial Processes Research Center - ISA Division
 - H - International Space Agriculture/Farming & Food Processing/Storage/Preparation Research Center – ISA Division
 - I - International Space Society Archive/Study/Research Center - ISA Division (Located at International Space Academy)
PhD Departments In: Government / Religion / Culture / Philosophy / Sciences / Arts / Media / Law / Military / History
 - J - International Space Commerce/Trade/Hospitality/Tourism - Global Cooperation & Research Center – ISA Division
 - K - Projects / Centers – Corporate & Academic Structure “Management/Supervisor/Employee - Organization Structure”

International Space Agency – Phase 1



Trademark & Copyright - 1986 to 2017

INTERNATIONAL SPACE AGENCY - I.S.A.
 UNITED SPACE FEDERATION - U.S.F.
 INTERNATIONAL SPACE ADMINISTRATION
 SCIENTIFIC -& AEROSPACE
 NOT FOR PROFIT CORPORATION
 NEW YORK STATE, UNITED STATES
 REGISTERED TRADEMARK 1986/2017
 REGISTERED COPYRIGHTS 1986/2017
 ALL RIGHTS ARE RESERVED

FOUNDED 1986 -& INCORPORATED 1990
 PRESENTLY SEEKING INTERNATIONAL
 TREATY AND CHARTER STATUS



Board of Directors
I.S.A.

Chairman
B.O.D.
I.S.A.

Assistant Director
I.S.A.

Director (C.E.O.)
I.S.A.

Board of Advisors
I.S.A.

Chairman
B.O.A.
I.S.A.

SPACE REGULATION COMMISSION
S R C
GOVERNING BODY -&-
REGULATORY BRANCH

INTERNATIONAL SPACE AGENCY ORGANIZATION
ISA

SPACE PLANNING COMMISSION
S P C
PLANNING BODY -&-
OVERSIGHT BRANCH

INTERNATIONAL SPACE ACADEMY
THE SPACE ACADEMY

CABINET -&- DIRECTOR -&- SENIOR OFFICERS

INTERNATIONAL SPACE NEWS ORGANIZATION
ISN

JUDGE ADVOCATE GENERAL (J.A.G.)

INTERNATIONAL SPACE ADMINISTRATION
ADMINISTRATION -&- EXECUTIVE BRANCH

ISA SOCIETIES

SECURITY -&- INVESTIGATIONS

HEADQUARTERS

ISA FOUNDATION

COMMANDS

ADMINISTRATION

CENTERS

MISSIONS

PROGRAMS

PROJECTS

OPERATIONS

SERVICES

RESEARCH

EXPLORATION

INFRASTRUCTURE

DEVELOPMENT

SETTLEMENT

ORGANIZATION

TECHNOLOGY

INTERNATIONAL SPACE AGENCY (ISA) - PHASE 1 - LEADERSHIP STRUCTURE

International Space Agency (ISA) Corporation - U.S.A. - Leadership Structure

- A) International Space Agency Corporation – United States of America
- ** Incorporated In 1990 – New York, USA – Scientific & Aerospace – Not-For-Profit Corporation
- B) International Space Agency Foundation – Global / International
- C) International Space Agency Foundation – World Society Congress – Global / International
- D) International Space Agency Societies – Nations / National
- E) International Space Agency Corporation – Commissions
- F) International Space Agency Foundation – Committees
- G) International Space Agency Society – Working Groups

A) International Space Agency (ISA) Corporation - U.S.A. - Board of Directors

ISA Vision Established Under A Clear Starry Sky In The Summer Of 1986 In Virginia Beach, Virginia, By: Admiral, Rick R. Dobson, Jr.
Incorporated 1990, Ithaca, New York (Birth Place At Cornell University – Special Thanks To: Dr. Frank Rhoads -and- Dr. Norman Scott)
Phase 1 - New York State, USA - Scientific & Aerospace Not-For-Profit Corporation (Diplomatic/Organizational Preparations For Phase 2)
Phase 2 - Presently Seeking International Charter -&- Treaty Status (Governmental Signatories To ISA Charter -&- Established Treaties)

International Space Agency Corporation – U.S.A. “Chief Executive Officers” - Senior Directors / Officers

Executive Leadership - International Space Agency / Command Flag Officers - International Space Administration

Director “Chief Executive Officer” (CEO) of the International Space Agency, I.S.A. / International Space Administration
ISA Board of Directors Voting Rights (13th Board Member), Veto Rights, First In ISA Control & Command (*ISA Director)
ISA Commanding Admiral (0-12) (5 Stars Gold) – “Appointed by the Board of Directors” / “Term Perpetual”

Assistant Director “Assistant Executive Officer” (AEO) of International Space Agency, I.S.A. / International Space Administration
ISA Board of Directors Voting Rights, Second Over All ISA Control & Command (**Chairperson, Board of Directors)
ISA Vice Commanding Admiral (0-11) (4 Stars Gold) – “Appointed by the Board of Advisors” / “Term Perpetual”

Executive Director of the International Space Agency, I.S.A. / International Space Administration
ISA Board of Directors Voting Rights, Third Over All ISA Control & Command (***) Vice Chairperson, Board of Directors)
Command Admiral (0-10) (3 Stars Gold) - “Appointed by ISA Officers Rank & File By Majority Vote Annually”/“Term Perpetual”

Deputy Director of the International Space Agency, I.S.A. / International Space Administration
ISA Board of Directors Voting Rights, Fourth Over All ISA Control & Command (****Secretary, Board of Directors)
Admiral (0-9) (3 Silver Stars) - “Appointed by ISA Non-Officers/Staff Rank & File By Majority Vote Annually” / “Term Perpetual”

Chief Vice Director of the International Space Agency, I.S.A. / International Space Administration
ISA Board of Advisors No Voting Rights, Fifth Over All ISA Control & Command (*****Chairman, Board of Advisors)
Admiral (0-9) (3 Silver Stars) – “Appointed by SRC By Majority Vote Annually” / “Term Perpetual”

Senior Vice Director of the International Space Agency, I.S.A. / International Space Administration
ISA Board of Advisors No Voting Rights, Sixth Over All ISA Control & Command (*****Vice Chairman, Board of Advisors)
Vice Admiral (0-8) (2 Silver Stars) – “Appointed by SPC By Majority Vote Annually” / “Term Perpetual”

Junior Vice Director of the International Space Agency, I.S.A. / International Space Administration
ISA Board of Advisors No Voting Rights, Seventh Over All ISA Control & Command (*****Secretary, Board of Advisors)
Rear Admiral (0-7) (1 Silver Star) – “Appointed by ISA Director” / “Term Perpetual”

International Space Agency Corporation – U.S.A. Board of Directors - “Full Voting Rights”

- 01) *Chairperson - ISA Vice Commanding Admiral (0-11) (4 Stars Gold) ISA Assistant Director “Assistant Executive Officer”
- 02) **Vice Chairperson - Command Admiral (0-10) (3 Stars Gold) - Chief Administrative Officer (CAO)
- 03) ***Secretary - Admiral (0-9) (3 Stars Silver) - Chief of Records (COR)
- 04) Commanding Officer Of The International Space Academy - Admiral (0-9) (3 Stars Silver)
- 05) Chief Legal Officer (CLO) “External” -&- Judge Advocate General “Internal” - Admiral (0-9) (3 Stars Silver)
- 06) Treasurer – Vice Admiral (0-8) (2 Stars Silver) - Chief Financial Officer (CFO)
- 07) Chief of Personnel -&- Facilities Security - Vice Admiral (0-8) (2 Stars Silver)
- 08) Chief of Data & Electronic Communications - Vice Admiral (0-8) (2 Stars Silver)
- 09) Chief of Programs -&- Commissions - Rear Admiral (0-7) (1 Silver Star)
- 10) Chief of Commands -&- Missions - Rear Admiral (0-7) (1 Silver Star)
- 11) Chief of Centers -&- Projects - Rear Admiral (0-7) (1 Silver Star)
- 12) Editor in Chief of International Space News - Captain (0-6) (Silver Crest)

International Space Agency Corporation – U.S.A.

Board of Advisors - “No Voting Rights Externally from Board of Advisors”

- 01) ****Chairperson - Admiral (0-9) (3 Stars Silver)
- 02) *****Vice Chairperson - Vice Admiral (0-8) (2 Stars Silver)
- 03) *****Secretary - Rear Admiral (0-7) (1 Silver Star)
- 04) Director of Government Space Affairs Office – Captain (0-6) (Silver Eagle)
- 05) Director of Commercial Space Affairs Office – Commander (0-5) (Silver Crest)
- 06) Director of Academic & Scientific Affairs Office – Lieutenant Commander (0-4) (Gold Crest)
- 07) Director of Space Institutions, NGO’s, Foundations, Societies Affairs Office – Lieutenant (0-3) (Silver Twin Bars)
- 08) Director of Public Affairs Officer for the International Space Agency Foundation & Societies – Lieutenant (0-3) (Silver Twin Bars)
- 09) Director of Public Affairs – Lieutenant (0-3) (Silver Twin Bars)
- 10) Director of Board of Advisors Outreach & Recruitment – Lieutenant (0-3) (Silver Twin Bars)
- 11) Director of Board of Advisors Internal Communications & Affairs – Lieutenant (0-3) (Silver Twin Bars)
- 12) **Members of the ISA Board of Advisors**
 - A) **Master Member** – Official Representative of a Government, Corporation, or Institute. - Lieutenant Junior Grade (0-2) (Silver Bar)
 - B) **Senior Member** – Recognized By ISA Administration as Critical Guild or Skill & Service More Than 4 Years – Ensign (0-1) (Gold Bar)
 - C) **Full Member** – Approved Voluntary Service of more than 4 years – Master Chief (E-9)
 - D) **Junior Member** - Approved Voluntary Service of less than 4 years, but more than 30 days - Senior Chief (E-8)
 - E) **Candidate Member** - Approved Voluntary Service of less than 30 days - Chief (E-7) or Petty Officer 1st Class (E6)

International Space Agency Organization – Programs /Projects / Missions Corporation Commissions / Foundation Committees / Society Working Group

ISA Corporation “USA” Commissions

Any Group formed by the International Space Agency Corporation Board of Directors to Review, Investigate, Research, or Implement any International Space Agency Program, Project, or Mission, which will be directly under the control of the International Space Agency Corporation Board of Directors at all times. Each International Space Agency Corporation Commission will have a Commission Chair, Co-Chair, and Secretary who will be appointed by the International Space Agency Corporation Director “Board Chair & CEO”. International Space Agency Corporation Commissions may be composed of several, or more, International Space Agency Foundation Committees, and in the case in which a Complex Commission is formed of numerous Committees, the International Space Agency Corporation Director “Board Chair & CEO” will appoint the Chairs of each Committee, and the International Space Agency Foundation “Vice” Chair will appoint Committee Co-Chairs and Secretaries.

ISA Foundation “Global” Committees

Any Group formed by the International Space Agency Foundation “International” Board of Directors to Review, Investigate, Research, or Implement any International Space Agency Program, Project, or Mission, which will be directly under the control of the International Space Agency Foundation “International” Board of Directors at all times. International Space Agency Corporation Director “Board Chair & CEO” will appoint the Chairs of each Committee, and the International Space Agency Foundation Chairman will appoint the Committee Co-Chairs and Secretaries.

ISA Societies “Nations/National” Working Groups

Any Group formed by any International Space Agency Society “Nation/National” Board of Directors to Review, Investigate, Research, or Implement any International Space Agency Program, Project, or Mission, which will be directly under the control of the International Space Agency Society “Nation/National” Board of Directors at all times. International Space Agency Foundation Chair “President - International ISA Society Congress” will appoint the Chair, Co-Chair, and Secretaries of each Working Group.

International Space Agency Corporation: Board of Directors / Officers / Board of Advisors

(Present) International Space Agency - Board of Directors:

- 01) **Admiral, Rick R. Dobson, Jr. – Chair (CEO) (USA/Nebraska/New York) (Circa. 1986)-1990/Present**
- 02) **Admiral, Mrs. Diane Rousseau, PhD, LHD – Vice Chair (AEO/CAO) (USA/Washington) 2013/Present**
- 03) **Commander, Dr. Alexander Bolonkin – Secretary (Chief Science Officer) (USA/New York) 2002/Present**
- 04) **Commander, Robert D McGown, M.Sci – Member (IME-PO) (USA/Oregon) 2013/Present**

(Former) International Space Agency - Board of Directors:

- ** **Dr. John Kadar, Professor - (USA/New York)(Founding Member) 1990/2002 – Never Formally Resigned**
 - ** **Mr. Matthew Baizer - Cornell (USA/New York) (Founding Member) 1990/2002 – Never Formally Resigned**
 - ** **Mr. Eric D. Byrd - Cornell (USA/New York) (Founding Member) 1990/2002 – Never Formally Resigned**
 - ** **Mr. Chris Anderson - Cornell (USA/New York) (Founding Member) 1990/2002 – Never Formally Resigned**
- 01) **Mr. Scott Huscroft - (USA/Nebraska) 2001/2003**
 - 02) **Dr. Morice Andem, Space Law Professor - (Finland/University) 2002/2004 – Never Formally Resigned**
 - 03) **Dr. David Maker - (USA/Alabama) 2003/2005 – Never Formally Resigned**
 - 04) **Mr. Mike J. McCarthy “U.S. Navy Commander Retired” - (USA-Pennsylvania) 2002/2006**
 - 05) **Dr. Jerald Schneider – (USA/Nebraska) 2002/2006**
 - 06) **Mr. Robert Daley – (USA/Nebraska) 2005/2007 – Never Formally Resigned**
 - 07) **Dr. Vadim Makarov - (Russia/USA/Nebraska) 2002/2006**
 - 08) **Dr. Rustam Rustamov – (Azerbaijan/University/ Azerbaijan National Space Agency) 2003/2007**
 - 09) **Mrs. Darla Quandt – (USA/Nebraska) (Assistant to Chairman/CEO) 2005/2013**
 - 10) **Dr. Liu Yonghua – (China/University) 2003/2007 – Never Formally Resigned**
 - 11) **Pastor Ralph Wright, PhD – (USA/Long Island, New York) 2002/2006**
 - 12) **Mr. Adam Jacobs, Attorney – (USA/Nebraska) 2002 / Died While In Office / Never Resigned**

(Present) International Space Agency - Board of Advisors:

- 01) **Admiral, Mrs. Diane Rousseau, PhD, LHD – “Acting” Chair (USA/Washington) 2015/Present**
- 02) **Commander, Robert D McGown, M.Sci – “Acting” Co-Chair (USA/Oregon) 2013/Present**

(Former) International Space Agency - Board of Advisors:

- ** **Mr. Tony F. Deboeck - Cornell (USA/New York) 1989/1993 - Father Worked For United Nations**
 - ** **Mr. Raul Rockwell - George Town University (USA/Washington DC) 1990/1994 - Never Formally Resigned**
 - ** **Dr. Norman Scott – Vice President of Cornell University (USA/New York) 1989/1991**
- 01) **Dr. Bill Biven - (USA/Nebraska) 2001/2003**
 - 02) **Mr. John A. Sellers, Attorney - (USA/Nebraska) 2002/2003**
 - 03) **Mr. Gary F. Wence, Attorney - (USA/Nebraska) 2002/2003**
 - 04) **Mr. Pournan Letchoumanane - (India/Bombay) 2003/2005**
 - 05) **Mr. Eric Ho - (USA/Nebraska)(*China/Hong Kong) 2003/2005 - Never Formally Resigned**
 - 06) **Dr. Jeroen Wouda - (Netherlands/European Space Agency,ESA) 2004/2005 - Never Formally Resigned**
 - 07) **Mr. Mike J. McCarthy “U.S. Navy Commander Retired” - (USA/Pennsylvania) 2007/2010**
 - 08) **Dr. Jerald Schneider – (USA/Nebraska) 2007/2010**
 - 09) **Mr. Dmitry Shats – (Russia/Moscow) - (Presently Living in America, Nebraska University) 2003/2006**
 - 10) **Mr. Rick Berkshire, Attorney – (USA/Nebraska) 2003/2005**
 - 11) **Mr. Tristan Laurant – (Living in China) (USA/New York) 2013/2014**
 - 12) **Dr. Susie Purtee, Police Officer / Private Investigator - (USA/Ohio) 2003/2007 (ISA Chief of Security)**
 - 13) **Dr. Deepak Kapadia – (India/Bombay) 2013/2015 - Never Formally Resigned “Still Semi-Active”**

(Present) International Space Agency - Officers / Staff (Many of the above listed people also served as Officers)

- 01) **Captain, Mr. Mike J. McCarthy “U.S. Navy Commander Retired” (USA/Pennsylvania) 2016/Present**
- 02) **Mrs. Shelli Leick “Mr. Chris Leick, Police Officer” (USA/Nebraska) 2011/Present**

NOTE: Many other people served in, and on the behalf of, the International Space Agency since 1986, but have been lost to time, or the records of them were destroyed when ISA Offices were firebombed in 2010. In 2013 the International Space Agency Foundation/Societies had nearly 400+ “and growing” active people globally involved; but due to espionage/criminal acts against the International Space Agency “www.linkedin.com” paid network, these names cannot be listed due to credibility issues. Since the International Space Agency had little financial resources for paid staff or security personnel, the vast majority of everything done to date, since 1986, by the International Space Agency, was largely done exclusively by ISA Founder, Admiral, Rick R. Dobson, Jr.

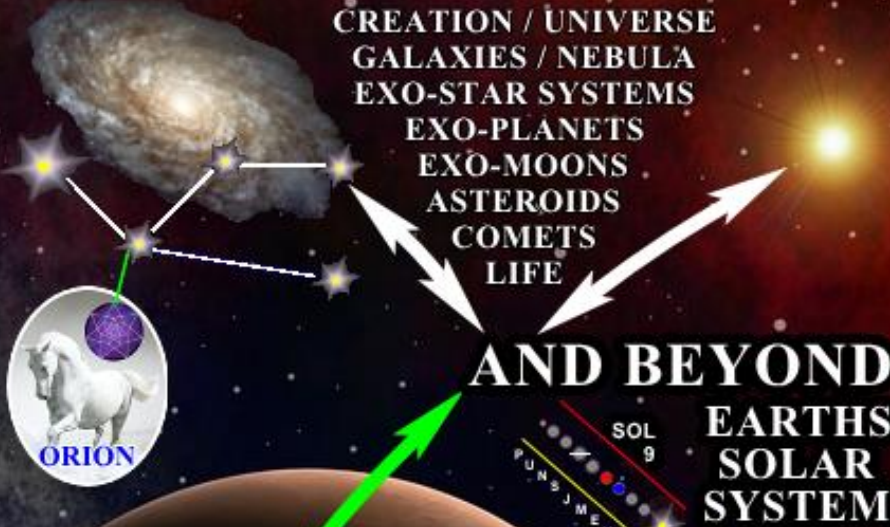

FROM THE STARS WE COME
TO THE STARS WE RETURN
~ IN PEACE ~
FOR ALL
~ MANKIND ~

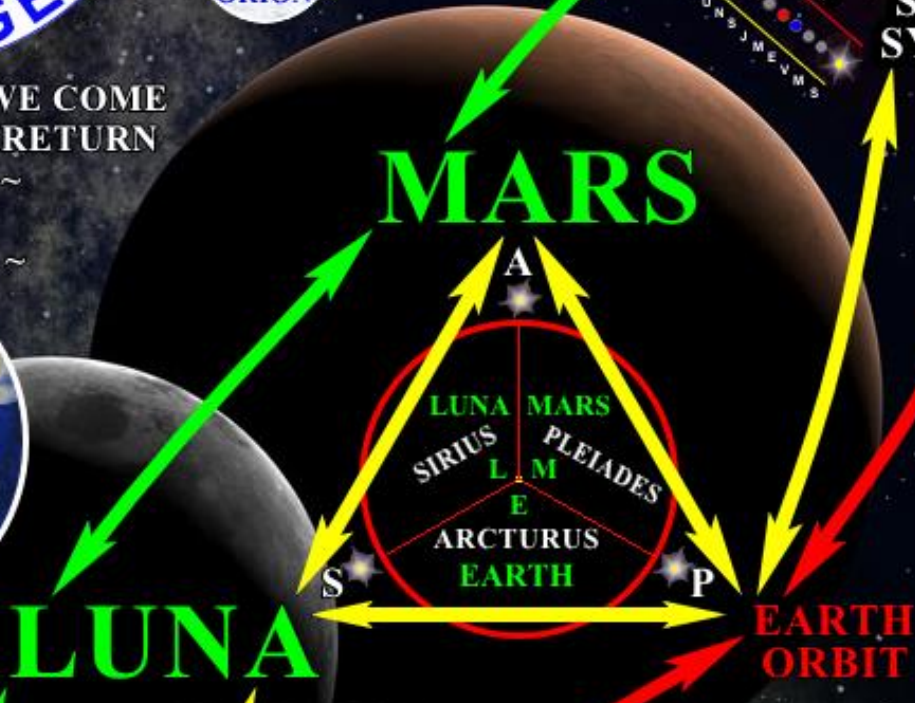

EARTH

1986 TO 2017
30+ YEARS OF HISTORY
COPYRIGHT -&- TRADEMARK
ALL RIGHTS ARE RESERVED

SEVEN "7" KEY - GATEWAY TECHNOLOGIES -&- PROGRAMS

**EARTH/LUNA/MARS/AND BEYOND
INTERNATIONAL SPACE
EXPLORATION PROGRAM**

**VISION & MISSION DIRECTIVES
SPACE TRANSPORTATION
INFRASTRUCTURE
TECHNOLOGY & PROGRAMS**



**CREATION
UNIVERSE**

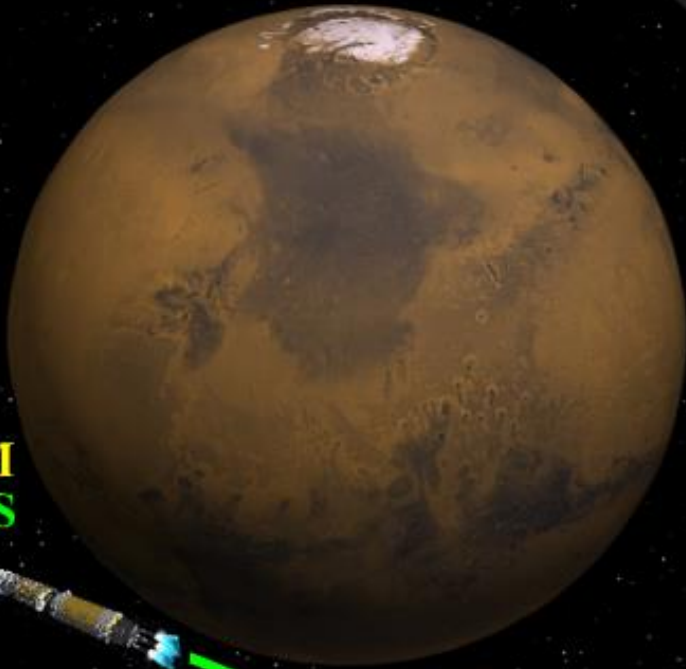
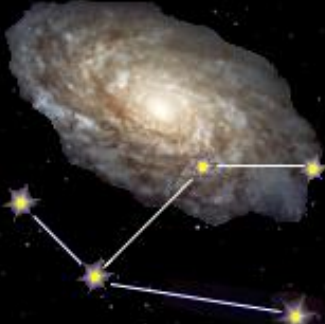

**SOLAR SYSTEM
LUNA * MARS
EARTH**



**EARTH
ORBIT**

**VISION -&-
MISSION
DIRECTIVES
INTERNATIONAL
SPACE
EXPLORATION
TECHNOLOGY
-&- PROGRAMS**



**International Space Agency
P.O. Box 541053
Omaha, Nebraska
68154**

**Omaha, Nebraska
(402) 299-2799
Washington, D.C.
(202) 917-0209**

**International Space Agency
1986 to 2017
30+ Years Of History
Copyright 1986 to 2017**

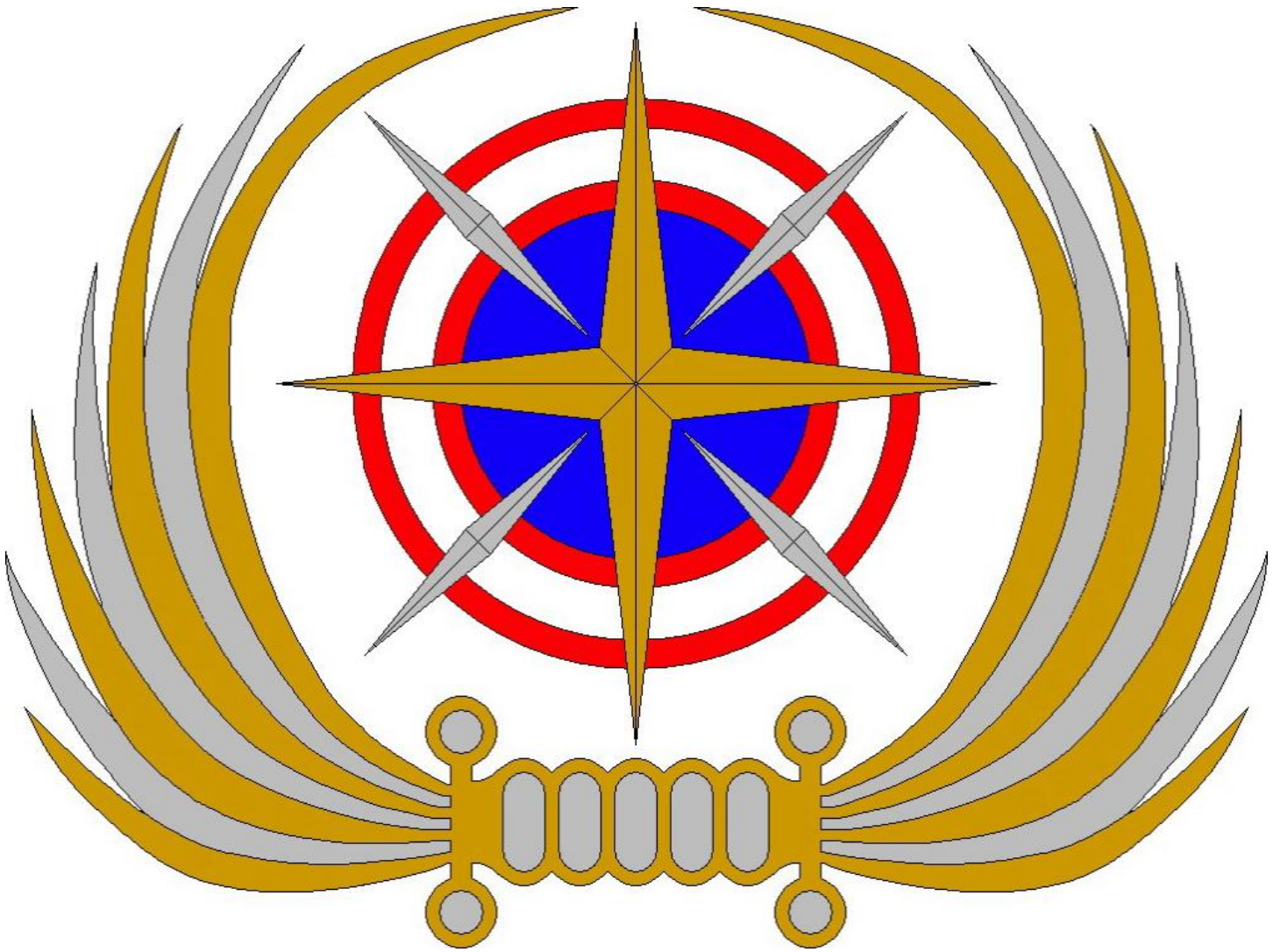

International Space Agency, ISA
International Space Administration
Founded In 1986 -&- Incorporated In 1990
Presently Seeking International Treaty -&- Charter Status

2013 - PROPOSAL

INTERNATIONAL SPACE AGENCY FOUNDATION
-and- INTERNATIONAL SPACE AGENCY SOCIETIES
ISA SOCIETY "NATIONAL - CHAPTERS/GROUPS/CLUBS"

2013 Proposal for the Establishment of the International Space Agency Foundation-& Societies

A. General Information

Project Title:	International Space Agency Foundation "I.S.A.F." – Division of the International Space Agency Corporation
Brief Project Description:	International Space Agency Organization - International/Global: Political Action, Recruitment, Public Outreach & Education, and also serves as Central Leadership and Headquarters for all International Space Agency "National" Societies, Globally.
Prepared By:	Admiral. Rick R. Dobson, Jr. - Founder, Chairman & CEO, International Space Agency
Date:	20 th October 2013 – "From: International Space Agency Thesis - Circa 1986/1988"

B. Project Objective:

PURPOSE: International Space Agency Foundation: is a Division of the International Space Administration which is the Executive (Administrative) Branch of International Space Agency Corporation. The International Space Agency Foundation is the "International" Board of Directors for the International Space Agency, and reports directly to the Board of Directors of the International Space Agency Corporation; and is the Central Leadership for the International Space Agency "National" Societies, Globally. Formed to provide Global "International" political activism and alternate private funding support for the International Space Agency, and to enable and support approved International Space Agency Programs, Projects, or Missions, which will be directly under the control of the International Space Agency Corporation Board of Directors at all times, and will be mainly used to encourage and support grass roots private citizens and NGO entities with a Global "International" view point and perspective for the International Space Agency Vision, Charter, Programs, Projects, and Mission.

Areas of International Space Agency Foundation "I.S.A.F." Authority:

International Space Agency Societies Congress "I.S.A.S.C." -and- International Space Agency Foundation Board of Directors

The President of each of the International Space Agency "National" Societies, Globally, sits as a Delegate "Senator", of the International Space Agency Societies Congress. Every 4 years the International Space Agency Societies Congress Elects 12 International Space Agency "National" Society Presidents "Senators" to sit on the **International Space Agency Foundation Board of Directors**. The Director (CEO) of the International Space Administration of the International Space Agency Corporation, then appoints one of the 12 Board Members of the International Space Agency Foundation to be the President / Vice Chair of the International Space Agency Foundation Board of Directors "Appointed Term 4 Years", and will act as the Chief Executive Officer (CEO) of International Space Agency Foundation; and who will also act as the Head "President" of the **International Space Agency Societies Congress "I.S.A.S.C."**, which is the collective body of all the Presidents "Senators" of each of the International Space Agency "National" Societies, Globally.

International Space Agency Societies Congress (I.S.A.S.C.)

Senators "Representatives" - President of each International Space Agency "National" Society, Globally

Mandatory - International Space Agency Societies Congress meets in Full Session, Every 4 Years, starting on first Saturday of January, for 9 days.

Airfare / Lodging / Food / Event Services are paid for by International Space Agency Foundation - & International Space Agency Corporation

* Friday - 9AM-10PM Delegates Arrival (Box Meals Provided To All Arriving Delegates) / 6PM-10PM Informal Meet and Greet Session

Day One: Saturday

7AM-12Noon Delegates Arrival / 12Noon Lunch / 1PM-6PM Admissions Session / 7PM-10PM Formal Dinner And Opening Presentation

Day Two: Sunday

6AM-7AM Breakfast / 7AM-12Noon (*) Committees & Working Groups Formation / 12Noon Lunch / 1PM-6PM (*) / 6PM Diner

Day Three: Monday

6AM-7AM Breakfast / 7AM-12Noon Working Session #1 / 12Noon Lunch / 1PM-6PM Working Session #2 / 6PM Diner

Day Three: Tuesday

6AM-7AM Breakfast / 7AM-12Noon Working Session #3 / 12Noon Lunch / 1PM-6PM Working Session #4 / 6PM Diner

Day Four: Wednesday

6AM-7AM Breakfast / 7AM-12Noon Working Session #5 / 12Noon Lunch / 1PM-6PM Working Session #6 / 6PM Diner

Day Five: Thursday

6AM-7AM Breakfast / 7AM-12Noon Working Session #7 / 12Noon Lunch / 1PM-6PM Working Session #8 / 6PM Diner

Days One to Five - Monday to Thursday

7PM-8PM Committees & Working Groups - Open Debate & Presentations Sessions / 8PM End Sessions & Snacks

Day Six: Friday

6AM-7AM Breakfast / 7AM-12Noon Committee Executive Sessions / 12Noon Lunch / 1PM-5PM Presentation Preparations are Finalized

Day Seven: Friday

5PM-6PM Diner / 6PM-Midnight (Twelve "12" Thirty "30" Minute) Committees Formal Video Presentations – Conclusions from 8 Working Sessions

Day Eight: Saturday

7AM-8AM Breakfast / 9AM to 12Noon Senators Open Session #1 / 12Noon Lunch / 1PM-4PM Senators Open Session #2

4PM-6PM - Elections & Voting Closed Session / 7PM-Midnight - Gala Dinner -and- Closing Presentations, Awards, and Entertainment

Day Nine: Sunday

7AM-8AM Breakfast / 9AM-11AM Open Executive Session / 11PM-12Noon Closed Executive Session / 12Noon Lunch/Check Out

The 12 Committees Are: 01) International Space Agency- Proposed Draft Charter 02) International Space Agency- Proposed 4 Year Main Directives/Priorities

03) International Space Agency- Proposed Key Divisions/Centers/Departments & Defined Purpose 04) International Space Agency- Proposed 7 Key Programs

05) International Space Agency- Proposed Key Science & Technology Projects 06) International Space Agency- Proposed Key Missions & Destinations

07) International Space Agency- Proposed Key Earth Orbital Infrastructure 08) International Space Agency- Proposed Orbital Space Stations/Facilities

09) International Space Agency- Proposed Planetary/Moon Launchers/ Landers 10) International Space Agency- Proposed Interplanetary: Ships/Craft/Probes

11) International Space Agency- Proposed International Luna Exploration 12) International Space Agency- Proposed International Mars Exploration

Each of the above 12 Committees: will be Broken Down into Working Groups, Representing Key, Defined, and Specific Elements, Categories, and Topics. Each Working Group will have a Director. Directors of all Working Groups of a Committee, will select one Director to be Chairman of that Committee. Each Committee will have following Key Positions: Chairman, Presentator, Video/Audio, Video/Audio Editor, Graphics, Artist, Text Editor, Writer, Typist, Researchers. Each Committee, and its Working Groups, will endeavor over "8" Eight (Five "5" Hour Working Sessions) to Create and Develop a Draft 30 Minute Professional Video Presentation for that Committee. All Committees Video Presentations will then be "Management & Peer" Reviewed over "4" Four, One "1" Hour, Debate and Brain Storming Sessions. All Committees Video Presentations will then be Reviewed by Management in a Five "5" Hour Committees Executive Session. Then each Committee will make Final Changes and Editing in a Four "4" Hour Session to its Video Presentation. Then all 12 Committees will show their 30 Minute Finished Videos to the entire ISA Societies Congress, ISA Foundation Board of Directors, and International Space Agency Participants and VIP Guests. These 30 Minute Videos will then be added into International Space Agency Corporation and International Space Agency Academy Archives & Data Bases, and also distributed to All International Space Agency "National" Societies, Globally. These 30 Minute Videos will also be distributed to National Space Agencies, Universities, Aerospace & Scientific Organizations, and Media, Globally.

Proprietary Information -& Trademark -& Copyright Protected – 1986 to 2013 - International Space Agency, I.S.A. - 20/10/2013 - Page 1 of 2

International Space Agency Foundation (I.S.A.F.) – Board of Directors “Directors”

Mandatory - Meets Weekly “Saturday” collectively in person or electronically for two to four “2-4” hours

Mandatory - Meets Monthly “First Saturday” collectively in person or electronically for four to eight “4-8” hours

Mandatory - Meets Annually “First Saturday & Sunday Of Every Year” in person “only” for two (twelve “12” hour working sessions)

Mandatory - Meets every 4 Years at the International Space Agency Society Congress (9 Days)

01 - “Acting” Chair (Is at all times the International Space Agency Corporation - Director & CEO)

02 - President- Vice Chair - Chief Executive Officer (CEO) - President of the “International Space Agency Societies Congress”

03 - Vice President - Executive Chair - Chief Administrative Officer (CAO)

04 - Secretary - Deputy Chair - Chief Records Officer (CRO)

05 - Treasurer - Chief Financial Officer (CFO) – Director for ISA Foundation Donations, Grants, Philanthropy Activities & ISA Society Dues

06 - Member - National Space Agency Relations Officer - (NSARO)

07 - Member - Government & Military Relations Officer - (GMRO)

08 - Member - Industrial & Commercial Relations Officer - (ICRO)

09 - Member - Science & Technology Relations Officer - (STRO)

10 - Member - University & Academic Relations Officer - (UARO) - (Universities, Colleges, Academies, Foundations, Societies, NGO's)

11 - Member - Chief Legal & Judicial Officer - (CLJO) - Judge Advocate General “JAG” for ISA Foundation and over all ISA Societies

12 - Member - Chief Security & Safety Officer - (CSSO)

13 - Member - Committees & Working Groups Officer - (CWGO) - Director for ISA Foundation Magazine & Newspaper

A - Appointed Officers & Directors - Serve at the Need, Direction, Oversight of the International Space Agency Foundation Board of Directors

B - International Space Agency Foundation - Board of Advisors - Officials, Professional Persons, Academics in Support to ISA Foundation

C - International Space Agency “National” Society Members, Volunteers, Supporters, Globally

International Space Agency Foundation (I.S.A.F.) - Committees: Any Group formed by the International Space Agency Foundation “International” Board of Directors to Review, Investigate, Research, or Implement any International Space Agency Program, Project, or Mission, which will be directly under the control of the International Space Agency Foundation “International” Board of Directors at all times. International Space Agency Corporation Director “Board Chair & CEO” will appoint the Chairs of each Committee, and the International Space Agency Foundation Chairman will appoint the Committee Co-Chairs and Secretaries. All approvals or directives for ISA Foundation Committees will come directly from the International Space Agency Corporation.

International Space Agency Societies “National - Chapters / Groups / Clubs”: are sanctioned and approved Groups of the International Space Agency Foundation, which is a Division of the International Space Administration, which is the Executive (Administrative) Branch of International Space Agency Corporation. The International Space Agency “National” Societies are the “National” Board of Directors for the International Space Agency, and reports directly to the Board of Directors of the International Space Agency Corporation. Formed to provide political activism and alternate private funding support for the International Space Agency, and to enable and support approved International Space Agency Programs, Projects, or Missions, which will be directly under the control of the International Space Agency Foundation “International” Board of Directors at all times, and will be mainly used to encourage and support grass roots private citizens and NGO entities with a “National” view point and perspective for the International Space Agency Vision, Charter, Programs, Projects, and Mission. International Space Agency “National” Societies are Independent “National - Chapters / Groups / Clubs” of the International Space Agency Foundation, and have: Over all oversight of National Citizens interested in supporting or joining the International Space Agency in their respective Nations Globally. The International Space Agency “National” Societies are Non-Profit, Non-Political, Non Governmental Societies of National Citizens who are voluntary members, and serve no official position or office in the International Space Agency Corporation. The International Space Agency “National” Societies have as their Official Charter the supporting of the International Space Agency Vision, Mission, and Endeavors through Debate, Activism, Philanthropy, and Common Association, by Citizens of Nations Globally. The International Space Agency “National” Societies will also act as a catalyst and enabler for National Citizens Globally to join the International Space Agency Corporation as Board Members, Officers, Staff, and Volunteers, and to engage in support of the International Space Agency Global Vision, Mission, Programs, Projects, Endeavors in their respective Nations and Communities, Globally.

International Space Agency Society (Chapter/Group/Club) “National” Board of Directors

Mandatory - Meets Weekly “Saturday” collectively in person or electronically for one to two “1-2” hours

Mandatory - Meets Monthly “First Saturday” collectively in person or electronically for two to four “2-4” hours

Mandatory - Meets Annually “First Saturday & Sunday Of Every Year” in person “advised” or electronically for two (twelve “12” hour working sessions)

Mandatory - Meets every 4 Years at the International Space Agency Society Congress (9 Days) in person “only”

01 - “Acting” Chair (Is at all times the International Space Agency Corporation - Director & CEO)

02 - President- Vice Chair - Chief Executive Officer (CEO) - President of the “International Space Agency Societies Congress”

03 - Vice President - Executive Chair - Chief Administrative Officer (CAO)

04 - Secretary - Deputy Chair - Chief Records Officer (CRO)

05 - Treasurer - Chief Financial Officer (CFO) – Director for ISA Society Donations, Grants, Philanthropy Activities & Membership Dues

06 - Member - National Space Agency Relations Officer - (NSARO)

07 - Member - Government & Military Relations Officer - (GMRO)

08 - Member - Industrial & Commercial Relations Officer - (ICRO)

09 - Member - Science & Technology Relations Officer - (STRO)

10 - Member - University & Academic Relations Officer - (UARO) - (Universities, Colleges, Academies, Foundations, Societies, NGO's)

11 - Member - Chief Legal & Judicial Officer - (CLJO)

12 - Member - Chief Security & Safety Officer - (CSSO)

13 - Member - Working Groups Officer - (WGO) - Director for ISA Foundation Magazine & Newspaper

International Space Agency “National” Societies - Working Groups: Any Group formed by any International Space Agency Society “Nation/National” Board of Directors to Review, Investigate, Research, or Implement any International Space Agency Program, Project, or Mission, which will be directly under the control of the International Space Agency Society “Nation/National” Board of Directors at all times. International Space Agency Foundation Vice Chair “President – International Space Agency Society Congress” will appoint the Chair of each Working Group. The President of International Space Agency “National” Society which has formed the Working Group, will appoint the Working Groups, Co-Chairs and Secretaries. All approvals or directives for ISA Society Working Groups will come directly from the International Space Agency Corporation.

BENEFITS: The International Space Agency Foundation (International Space Agency Foundation Board of Directors & Board of Advisors & Officers & Volunteers -and- International Space Agency Societies Congress “Senators” -and- International Space Agency “National” Societies, Globally) will provided a diverse and broad spectrum of human resources, specialized expertise and knowledge, political action, funding stream and base, governmental and non-governmental support and participation, and creativity and vision; which can enable, support, and magnify the Primary Vision, Mission, and Endeavors of the International Space Agency Organization, Globally; and act as a critical enabler and support base for International Space Agency and its International Space Exploration: Programs, Projects, and Missions.



International Space Agency , I.S.A. International Space Administration

PURPOSE: International Space Agency Foundation: is a Division of the International Space Administration which is the Executive (Administrative) Branch of International Space Agency Corporation. The International Space Agency Foundation is the "International" Board of Directors for the International Space Agency, and reports directly to the Board of Directors of the International Space Agency Corporation; and is the Central Leadership for the International Space Agency "National – Chapters /Groups / Clubs" Societies, Globally. Formed to provide Global "International" political activism and alternate private funding support for the International Space Agency, and to enable and support approved International Space Agency Programs, Projects, or Missions, which will be directly under the control of the International Space Agency Corporation Board of Directors at all times, and will be mainly used to encourage and support grass roots private citizens and NGO entities with a Global "International" view point and perspective for the International Space Agency Vision, Charter, Programs, Projects, and Mission. International Space Agency Societies Congress (I.S.A.S.C.), Senators "Representatives", President of each International Space Agency "National" Society, Globally, meets in Full Session, Every 4 Years, starting on first Saturday of January, for 9 days.



INTERNATIONAL SPACE AGENCY FOUNDATION
 The purpose of the International Space Agency Foundation is to act as the central focal point for the many International Space Agency Societies (National: Chapters, Groups, Clubs) around the World. The I.S.A. Foundation has an International Focus, while the many I.S.A. Societies, consisting of National: Chapters, Groups, and Clubs have more of a National Focus.

INTERNATIONAL SPACE AGENCY SOCIETIES
 NATIONAL CHAPTERS ARE 1000+ MEMBERS OR MORE
 NATIONAL GROUPS ARE 100+ MEMBERS OR MORE
 NATIONAL CLUBS ARE 10+ MEMBERS OR MORE



**UNITED STATES
 ISA
 SOCIETY**



IN PEACE FOR ALL MANKIND
 AD-ASTRA! TO THE STARS!



**INDIA
 ISA
 SOCIETY**



IN PEACE FOR ALL MANKIND
 AD-ASTRA! TO THE STARS!



**ROMANIA
 ISA
 SOCIETY**



IN PEACE FOR ALL MANKIND
 AD-ASTRA! TO THE STARS!



**BRAZIL
 ISA
 SOCIETY**



IN PEACE FOR ALL MANKIND



INTERNATIONAL SPACE AGENCY FOUNDATION
 The purpose of the International Space Agency Foundation is to act as the central focal point for the many International Space Agency Societies (National: Chapters, Groups, Clubs) around the World. The I.S.A. Foundation has an International Focus, while the many I.S.A. Societies, consisting of National: Chapters, Groups, and Clubs have more of a National Focus.

INTERNATIONAL SPACE AGENCY SOCIETIES
 NATIONAL CHAPTERS ARE 1000+ MEMBERS OR MORE
 NATIONAL GROUPS ARE 100+ MEMBERS OR MORE
 NATIONAL CLUBS ARE 10+ MEMBERS OR MORE



International Space Agency Foundation “International” Board of Directors

International Space Agency Foundation is a Division of the International Space Administration which is the Executive (Administrative) Branch of International Space Agency Corporation. The International Space Agency Foundation is the “International” Board of Directors for the International Space Agency, and reports directly to the Board of Directors of the International Space Agency Corporation; and is the Central Leadership for the National ISA Societies Globally.

International Space Agency Foundation is a International Division of the International Space Agency Corporation, formed to provide Global “International” political activism and alternate private funding support for the International Space Agency, and to enable and support approved International Space Agency Programs, Projects, or Missions, which will be directly under the control of the International Space Agency Corporation Board of Directors at all times, and will be mainly used to encourage and support grass roots private citizens and NGO entities with a Global “International” view point and perspective for the ISA Vision, Charter, Programs, Projects, and Mission.

ISA Foundation “International” Executive Directors

- 01 - “Acting” Chairman ** (International Space Agency Corporation - Director)
- 02 - President / “Vice” Chairman - Chief Executive Officer (CEO) ** President of the “International ISA Societies Congress”
- 03 - Vice President - Chief Administrative Officer (CAO)
- 04 - Secretary - Chief Records Officer (CRO)
- 05 - Treasurer - Chief Financial Officer (CFO)
- 06 - Government Relations Officer - (GRO)
- 07 - Commercial Relations Officer - (CRO)
- 08 - Scientific Relations Officer - (SRO)
- 09 - Academic Relations Officer - (ARO)
- 10 - Military Relations Officer - (MRO)
- 11 - Chief Legal Officer - (CLO)
- 12 - Chief Security Officer - (CSO)
- 13 - Committees & Working Groups Officer - (CWGO)

ISA Foundation “International” Senators (International ISA Societies Congress)

- 14 – Senators - International Societies Congress (Presidents of ISA “National” Societies)
- 15 – Chairs of ISA Foundation Committees -and- 16 – Chairs of ISA Society Working Groups

International ISA Societies Congress

The President of each National ISA Society sits as a Delegate “Senator” of the International Space Agency Foundation “International ISA Societies Congress”. Every 4 years the International Space Agency Foundation “International ISA Societies Congress” Elects 12 of the National ISA Society Presidents “Senators” to sit on the International Space Agency Foundation “International” Board of Directors. The Director of the International Space Administration of the International Space Agency Corporation, then appoints one of the 12 “Elected” Board Members “Senators” of the International Space Agency Foundation to be the Chief Executive Officer of the International Space Agency Foundation, who will act as the Head of all the National ISA Societies Globally, and will also sit as “Vice” Chair for the International Space Agency Foundation “International” Board of Directors” for an appointed term of 4 years. The Chief Executive Officer of the International Space Agency Foundation, will also act as the President of the “International ISA Societies Congress” at its annual week long session. The “International ISA Societies Congress” meets collectively in full session once annually at an appointed place and date. The Board of Directors of the International Space Agency Foundation will meet collectively once per month in a “2 day closed session” at an appointed place and date.

International Space Agency Foundation ISAF - World Space Societies Congress

International Space Agency Foundation is a Division of International Space Administration which is the Executive (Administrative) Branch of International Space Agency Corporation. The International Space Agency Foundation is the International Board of Directors for the National ISA Societies Globally.

The President of each National ISA Society sits as a Delegate of the International Space Agency Foundation Congress. Every 4 years the International Space Agency Foundation Congress Elects 12 National ISA Presidents to sit on the ISA Foundation

Board of Directors. Director of the International Space Administration of the International Space Agency, then appoints one of the 12 Board Members of the International Space Agency Foundation to be Chief Executive Officer of International Space Agency Foundation who will act as the Head of all National ISA Societies Globally, and will also sit as the Chairperson for International Space Agency Foundation Board of Directors for an appointed term of 4 years.

International Space Agency Foundation 2013 Board of Directors

- 01) **Chairperson** (Chief Executive Officer - CEO) – Appointed by the ISA Director
- 02) **Vice Chairperson** – Voted on by the ISA Foundation Board of Directors
- 03) **Secretary** – Appointed by the Chairperson
- 04) **Treasurer** – Appointed by the Chairperson
- 05) Global ISA Society Public & Relations - Appointed by the Chairperson
- 06) Global ISA Society Membership Relations - Appointed by the Chairperson
- 07) Global ISA Society Events Coordinator - Appointed by the Chairperson
- 08) Director of Academic & Student Affairs - Appointed by the Vice Chairperson
- 09) Director of Scientific & Technology Affairs - Appointed by the Vice Chairperson
- 10) Director of Records & Data - Appointed by the Vice Chairperson
- 11) Director of Donations & Grants - Appointed by the Vice Chairperson
- 12) Director of ISA Foundation Magazine - Appointed by the Vice Chairperson

2013 - World Space Societies - Congress Delegates

- 01) **India - Mr. Ashish Shrivastava – Official Group – 103 Members**
- 02) **United States - Ms. Beverly H. Coan – Official Club – 29 Members**
- 03) **Romania - Ms. Corina Stiubei – Official Club – 11 Members**
- 04) **Brazil - Dr. Roger Ribeiro Riehl – Official Club – 11 Members**
- 05) **Italy - Mr. Nicola Evangelista – Official Club – 11 Members**
- 06) **Georgia - Dr. Prof. George Jandieri – Official Club – 11 Members**
- 07) **United Kingdom - Mr. Tony James – 9 Members – “Not 3 Officers”**
- 08) **Serbia - Mr. Dusan Drndarski – 5 Members – “Not 3 Officers”**
- 09) **Nigeria - Mr. Ayodele Onibudo – 5 Members**
- 10) **Iceland - Dr. Thorsteinn Olafsson – 4 Members – “Not 3 Officers”**
- 11) **Iran - Mr. Soheil Salimi – 3 Members – “Not 3 Officers”**



International Space Agency Societies “Nation/National”

Any International Space Agency Foundation “National” Chapters, Groups, or Clubs formed to provide political activism and alternate private funding support for the International Space Agency, and to enable and support approved International Space Agency Programs, Projects, or Missions, which will be directly under the control of the International Space Agency Foundation “International” Board of Directors at all times, and will be mainly used to encourage and support grass roots private citizens and NGO entities with a “National” view point and perspective for the ISA Vision, Charter, Programs, Projects, and Mission.

International Space Agency “National” Societies (Chapters / Groups / Clubs)

International Space Agency Societies are Independent National “Chapters / Groups / Clubs” of the International Space Agency Foundation, and have: Over all oversight of National Citizens interested in supporting or joining the International Space Agency in their respective Nations Globally. The National ISA Societies are Non-Profit, Non-Political, Non Governmental Societies of National Citizens who are voluntary members, and serve no official position or office in the International Space Agency. The National ISA Societies have as there Official Charter the supporting of the International Space Agency Vision, Mission, and Endeavors through Debate, Activism, Philanthropy, and Common Association, by Citizens of Nations Globally. The National ISA Societies will also act as a catalyst and enabler for National Citizens Globally to join the International Space Agency as Board Members, Officers, Staff, and Volunteers, and to engage in support of the International Space Agency Global Vision, Mission, Programs, Projects, Endeavors in their respective Nations and Communities Globally.

International Space Agency Society (Chapter/Group/Club) “National” Board of Directors

- | | |
|---|---|
| 01 - “Acting” Chairman | ** (International Space Agency Corporation - Director) |
| 02 - President / “Vice” Chair - Chief Executive Officer (CEO) | * (Must be a Naturalized Citizen from the Host Country) |
| ** Senator “International ISA Societies Congress” | ** (Appointed or Approved by the Host Government) |
| 03 - Vice President - Chief Administrative Officer (CAO) | * (Must be a Naturalized Citizen from the Host Country) |
| 04 - Secretary - Chief Records Officer (CRO) | * (Must be a Naturalized Citizen from the Host Country) |
| 05 - Treasurer - Chief Financial Officer (CFO) | * (Must be a Naturalized Citizen from the Host Country) |
| 06 - Government Relations Officer - (GRO) | * (Must be a Naturalized Citizen from the Host Country) |
| 07 - Commercial Relations Officer - (CRO) | * (Must be a Naturalized Citizen from the Host Country) |
| 08 - Scientific Relations Officer - (SRO) | * (Must be a Naturalized Citizen from the Host Country) |
| 09 - Academic Relations Officer - (ARO) | * (Must be a Naturalized Citizen from the Host Country) |
| 10 - Military Relations Officer - (MRO) | * (Must be a Naturalized Citizen from the Host Country) |
| 11 - Chief Legal Officer - (CLO) | * (Must be a Naturalized Citizen from the Host Country) |
| 12 - Chief Security Officer - (CSO) | * (Must be a Naturalized Citizen from the Host Country) |
| 13 - Working Groups Officer - (WGO) | * (Must be a Naturalized Citizen from the Host Country) |

International Space Agency Organization – Programs /Projects / Missions Corporation Commissions / Foundation Committees / Society Working Group

E) ISA Corporation “USA” Commissions

Any Group formed by the International Space Agency Corporation Board of Directors to Review, Investigate, Research, or Implement any International Space Agency Program, Project, or Mission, which will be directly under the control of the International Space Agency Corporation Board of Directors at all times. Each International Space Agency Corporation Commission will have a Commission Chair, Co-Chair, and Secretary who will be appointed by the International Space Agency Corporation Director “Board Chair & CEO”. International Space Agency Corporation Commissions may be composed of several, or more, International Space Agency Foundation Committees, and in the case in which a Complex Commission is formed of numerous Committees, the International Space Agency Corporation Director “Board Chair & CEO” will appoint the Chairs of each Committee, and the International Space Agency Foundation “Vice” Chair will appoint the Committee Co-Chairs and Secretaries.

F) ISA Foundation “Global” Committees

Any Group formed by the International Space Agency Foundation “International” Board of Directors to Review, Investigate, Research, or Implement any International Space Agency Program, Project, or Mission, which will be directly under the control of the International Space Agency Foundation “International” Board of Directors at all times. International Space Agency Corporation Director “Board Chair & CEO” will appoint the Chairs of each Committee, and the International Space Agency Foundation Chairman will appoint the Committee Co-Chairs and Secretaries.

G) ISA Societies “Nations/National” Working Groups

Any Group formed by any International Space Agency Society “Nation/National” Board of Directors to Review, Investigate, Research, or Implement any International Space Agency Program, Project, or Mission, which will be directly under the control of the International Space Agency Society “Nation/National” Board of Directors at all times. International Space Agency Foundation Chair “President - International ISA Society Congress” will appoint the Chair, Co-Chair, and Secretaries of each Working Group.



INTERNATIONAL SPACE AGENCY FOUNDATION

The purpose of the International Space Agency Foundation is to act as the central focal point for the many International Space Agency Societies (National: Chapters, Groups, Clubs) around the World. The I.S.A. Foundation has an International Focus, while the many I.S.A. Societies, consisting of National: Chapters, Groups, and Clubs have more of a National Focus.

- INTERNATIONAL SPACE AGENCY SOCIETIES**
- NATIONAL CHAPTERS ARE 1000+ MEMBERS OR MORE
- NATIONAL GROUPS ARE 100+ MEMBERS OR MORE
- NATIONAL CLUBS ARE 10+ MEMBERS OR MORE



UNITED STATES ISA SOCIETY



IN PEACE FOR ALL MANKIND
AD-ASTRA! TO THE STARS!



INDIA ISA SOCIETY



IN PEACE FOR ALL MANKIND
AD-ASTRA! TO THE STARS!



ROMANIA ISA SOCIETY



IN PEACE FOR ALL MANKIND
AD-ASTRA! TO THE STARS!



BRAZIL ISA SOCIETY



IN PEACE FOR ALL MANKIND
AD-ASTRA! TO THE STARS!



ICELAND ISA SOCIETY



IN PEACE FOR ALL MANKIND
AD-ASTRA! TO THE STARS!



GEORGIA ISA SOCIETY



IN PEACE FOR ALL MANKIND
AD-ASTRA! TO THE STARS!

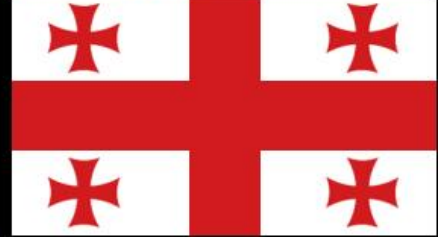

2013 Active National - ISA Societies -&- Officers

There Are 347 Active National ISA Society Members In 2013

India - ISA Society - International Space Agency Foundation

<http://www.linkedin.com/groups?gid=4917847>

India ISA Society Is A Member Group of the International Space Agency Foundation which is a Division of the International Space Administration which is a Branch of International Space Agency Corporation.

Here are the 2013 Officers of the India ISA Society:

Mr. Ashish Shrivastava

President - India ISA Society

Profile: <http://in.linkedin.com/in/shrivastvaashish>

Email: ashish.shrivastava@international-space-agency.us

Miss. Aakanksha Shirbhate

Vice President - India ISA Society

Profile: <http://uk.linkedin.com/in/aakanksha2806>

Email: aakanksha.shirbhate@international-space-agency.us

Mr. Joshane Kelsy

Secretary - India ISA Society

Profile: <http://in.linkedin.com/in/joshanekelsy>

Email: joshane.kelsy@international-space-agency.us

India - ISA Society - Charter - Over all oversight of Indian Citizens interested in supporting or joining the International Space Agency in India. The India ISA Society is a Non-Profit, Non-Political, Non-Governmental Society of Indian Citizens who are voluntary members, and serve no official position or office in the International Space Agency. The India ISA Society has as its Official Charter the supporting of the International Space Agency Vision, Mission, and Endeavors through Debate, Activism, Philanthropy, and Common Association, by Citizens of India. The India ISA Society will also act as a catalyst and enabler for Indian Citizens to join the International Space Agency as Officers, Staff, and Board Members, to engage in support of the International Space Agency Global Vision, Mission, Programs, Projects, Endeavors.

United States - ISA Society - International Space Agency Foundation

<http://www.linkedin.com/groups?gid=4916055>

United States ISA Society Is A Member Group of the International Space Agency Foundation which is a Division of the International Space Administration which is a Branch of International Space Agency Corporation.

Here are the 2013 Officers of the United States ISA Society:

Ms. Beverly H. Coan

President - United States ISA Society

Profile: <http://www.linkedin.com/pub/beverly-coan/10/271/580>

Email: beverly.h.coan@international-space-agency.us

Mr. Martin Cabaniss

Vice President - United States ISA Society

Profile: <http://www.linkedin.com/in/cabanissaero>

Email: martin.cabaniss@international-space-agency.us

Mr. Kenneth Edson Ford

Secretary - United States ISA Society

Profile: <http://www.linkedin.com/in/kennethford>

Email: kenneth.edson.ford@international-space-agency.us

United States of America - ISA Society - Charter - Over all oversight of American Citizens interested in supporting or joining the International Space Agency in the United States. The United States ISA Society is a Non-Profit, Non-Political, Non Governmental Society of American Citizens who are voluntary members, and serve no official position or office in the International Space Agency. The United States ISA Society has as its Official Charter the supporting of the International Space Agency Vision, Mission, and Endeavors through Debate, Activism, Philanthropy, and Common Association, by Citizens of United States. The United States ISA Society will also act as a catalyst and enabler for American Citizens to join the International Space Agency as Officers, Staff, and Board Members, and to engage in support of the International Space Agency Global Vision, Mission, Programs, Projects, and Endeavors.

India ISA Society Members - 103



United States ISA Society Members - 29



Romania - ISA Society - International Space Agency Foundation

<http://www.linkedin.com/groups?gid=6500919>

Romania ISA Society Is A Member Group of the International Space Agency Foundation which is a Division of the International Space Administration which is a Branch of International Space Agency Corporation.

Here are the 2013 Officers of the Romania ISA Society:

Ms. Corina Stiubei

President - Romania ISA Society

Profile: <http://www.linkedin.com/in/corinastiubei>

Email: corina.stiubei@international-space-agency.us

Mr. George Dan Muntean

Vice President - Romania ISA Society

Profile: <http://ro.linkedin.com/pub/george-dan-muntean/63/567/157>

Email: george.dan.muntean@international-space-agency.us

Mr. Mihai Deaconu

Secretary - Romania ISA Society

Profile: <http://ro.linkedin.com/pub/mihai-deaconu/2a/a6b/448>

Email: mihai.deaconu@international-space-agency.us

Romania ISA Society Members - 11



Romania - ISA Society - Charter - Over all oversight of Romanian Citizens interested in supporting or joining the International Space Agency in Romania. The Romania ISA Society is a Non-Profit, Non-Political, Non Governmental Society of Romanian Citizens who are voluntary members, and serve no official position or office in the International Space Agency. The Romania ISA Society has as its Official Charter the supporting of the International Space Agency Vision, Mission, and Endeavors through Debate, Activism, Philanthropy, and Common Association, by Citizens of Romania. The Romania ISA Society will also act as a catalyst and enabler for Romanian Citizens to join the International Space Agency as Officers, Staff, Board Members and to engage in support of the International Space Agency Global Vision, Mission, Programs, Projects, Endeavors

Brazil - ISA Society - International Space Agency Foundation

<http://www.linkedin.com/groups?gid=491792>

Brazil ISA Society Is A Member Group of the International Space Agency Foundation which is a Division of the International Space Administration which is a Branch of International Space Agency Corporation.

Here are the 2013 Officers of the Brazil ISA Society:

Dr. Roger Ribeiro Riehl

President – Brazil ISA Society

Profile: <http://br.linkedin.com/pub/roger-riehl/20/670/15>

Email: roger.ribeiro.riehl@international-space-agency.us

Dr. Sergio Cabral Cavalcanti

Vice President – Brazil ISA Society

Profile: <http://br.linkedin.com/in/sergiocabral>

Email: sergio.cabral.cavalcanti@international-space-agency.us

Dr. Boris Petrovic

Secretary – Brazil ISA Society

Profile: <http://br.linkedin.com/in/borispetrovic>

Email: @international-space-agency.us

Brazil ISA Society Members - 11



Brazil - ISA Society - Charter - Over all oversight of Brazilian Citizens interested in supporting or joining the International Space Agency in Brazil. The Brazil ISA Society is a Non-Profit, Non-Political, Non-Governmental Society of Brazilian Citizens who are voluntary members, and serve no official position or office in the International Space Agency. The Brazil ISA Society has as its Official Charter the supporting of the International Space Agency Vision, Mission, and Endeavors through Debate, Activism, Philanthropy, and Common Association, by Citizens of Brazil. The Brazil ISA Society will also act as a catalyst and enabler for Brazilian Citizens to join the International Space Agency as Officers, Staff, and Board Members, to engage in support of the International Space Agency Global Vision, Mission, Programs, Projects, Endeavors.

Georgia - ISA Society - International Space Agency Foundation

<http://www.linkedin.com/groups?gid=5185998>

Georgia ISA Society Is A Member Group of the International Space Agency Foundation which is a Division of the International Space Administration which is a Branch of International Space Agency Corporation.

Here are the 2013 Officers of the Georgia ISA Society:

Mr. Prof. George Jandieri

President - Georgia ISA Society

Profile: <http://www.linkedin.com/pub/george-jandieri/47/b00/873>

Email: george.jandieri@international-space-agency.us

Mr. Prof. Zhuzhuna Diasamidze

Vice President - Georgia ISA Society

Profile: ?? "No LinkedIn URL" ??

Email: zhuzhuna.diasamidze@international-space-agency.us

Mr. Prof. Tamar Bzhalava

Secretary - Georgia ISA Society

Profile: <http://www.linkedin.com/pub/tamar-bzhalava/40/b6/b50>

Email: tamar.bzhalava@international-space-agency.us

Georgia ISA Society Members - 11

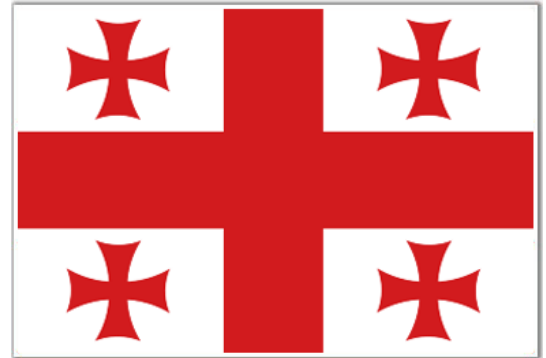

Georgia - ISA Society - Charter - Over all oversight of Georgian Citizens interested in supporting or joining the International Space Agency in Georgia. The Georgia ISA Society is a Non-Profit, Non-Political, Non-Governmental Society of Georgian Citizens who are voluntary members, and serve no official position or office in the International Space Agency. The Georgia ISA Society has as its Official Charter the supporting of the International Space Agency Vision, Mission, and Endeavors through Debate, Activism, Philanthropy, and Common Association, by Citizens of Georgia. The Georgia ISA Society will also act as a catalyst and enabler for Georgian Citizens to join the International Space Agency as Officers, Staff, Board Members, and to engage in support of the International Space Agency Global Vision, Mission, Programs, Projects, and Endeavors

Italy - ISA Society - International Space Agency Foundation

<http://www.linkedin.com/groups?gid=4985093>

Italy ISA Society Is A Member Group of the International Space Agency Foundation which is a Division of the International Space Administration which is a Branch of International Space Agency Corporation.

Here are the 2013 Officers of the Italy ISA Society:

Mr. Nicola Evangelista

President - Italy ISA Society

Profile: <http://uk.linkedin.com/pub/nicola-evangelista/3a/562/142>

Email: nicola.evangelista@international-space-agency.us

"Vacant"

Vice President – Italy ISA Society

Profile: N/A

Email: @international-space-agency.us

"Vacant"

Secretary – Italy ISA Society

Profile: N/A

Email: @international-space-agency.us

Italy ISA Society Members - 11

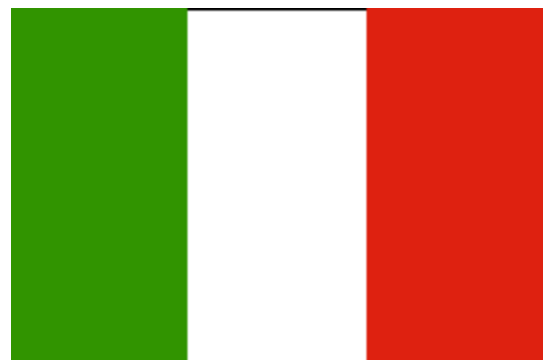

Italy - ISA Society - Charter - Over all oversight of Italian Citizens interested in supporting or joining the International Space Agency in Italy. The Italy ISA Society is a Non-Profit, Non-Political, Non Governmental Society of Italian Citizens who are voluntary members, and serve no official position or office in the International Space Agency. The Italy ISA Society has as its Official Charter the supporting of the International Space Agency Vision, Mission, and Endeavors through Debate, Activism, Philanthropy, and Common Association, by Citizens of Italy. The Italy ISA Society will also act as a catalyst and enabler for Italian Citizens to join the International Space Agency as Officers, Staff, and Board Members, to engage in support of the International Space Agency Global Vision, Mission, Programs, Projects, Endeavors.

United Kingdom - ISA Society - International Space Agency Foundation

<http://www.linkedin.com/groups?gid=4926226>

United Kingdom ISA Society Is A Member Group of the International Space Agency Foundation which is a Division of the International Space Administration which is a Branch of International Space Agency Corporation.

Here are the 2013 Officers of the United Kingdom ISA Society:

Mr. Tony James

President - United Kingdom ISA Society

Profile: <http://uk.linkedin.com/in/cyberwebspace>

Email: tony.james@international-space-agency.us

Mr. Anthony Masuku

Vice President - United Kingdom ISA Society

Profile: <http://www.linkedin.com/profile/view?id=48858772>

Email: another.masuka@international-space-agency.us

"Vacant"

Secretary – United Kingdom ISA Society

Profile: N/A

Email: @international-space-agency.us

United Kingdom ISA Society Members - 9



United Kingdom - ISA Society – Charter - Over all oversight of British Citizens interested in supporting or joining the International Space Agency in the United Kingdom. The United Kingdom ISA Society is a Non-Profit, Non-Political, Non Governmental Society of British Citizens who are voluntary members, and serve no official position or office in the International Space Agency. The United Kingdom ISA Society has as its Official Charter the supporting of the International Space Agency Vision, Mission, and Endeavors through Debate, Activism, Philanthropy, and Common Association, by Citizens of United Kingdom. The United Kingdom ISA Society will also act as a catalyst and enabler for British Citizens to join the International Space Agency as Officers, Staff, and Board Members, and to engage in support of the International Space Agency Global Vision, Mission, Programs, Projects, and Endeavors.

Serbia - ISA Society - International Space Agency Foundation

<http://www.linkedin.com/groups?gid=6512042>

Serbia ISA Society Is A Member Group of the International Space Agency Foundation which is a Division of the International Space Administration which is a Branch of International Space Agency Corporation.

Here are the 2013 Officers of the Serbia ISA Society:

Mr. Dusan Drndarski

President - Serbia ISA Society

Profile: <http://www.linkedin.com/profile/view?id=60039254>

Email: dusan.drudarski@international-space-agency.us

"Vacant"

Vice President –Serbia ISA Society

Profile: N/A

Email: @international-space-agency.us

"Vacant"

Secretary –Serbia ISA Society

Profile: N/A

Email: @international-space-agency.us

Serbia ISA Society Members - 5



Serbia - ISA Society - Charter - Over all oversight of Serbian Citizens interested in supporting or joining the International Space Agency in Serbia. The Serbia ISA Society is a Non-Profit, Non-Political, Non Governmental Society of Serbian Citizens who are voluntary members, and serve no official position or office in the International Space Agency. The Serbia ISA Society has as its Official Charter the supporting of the International Space Agency Vision, Mission, and Endeavors through Debate, Activism, Philanthropy, and Common Association, by Citizens of Serbia. The Serbia ISA Society will also act as a catalyst and enabler for Serbian Citizens to join the International Space Agency as Officers, Staff, and Board Members, to engage in support of the International Space Agency Global Vision, Mission, Programs, Projects, Endeavors.

Nigeria ISA Society – International Space Agency Foundation

<http://www.linkedin.com/groups?gid=4956477>

Nigeria ISA Society Is A Member Group of the International Space Agency Foundation which is a Division of the International Space Administration which is a Branch of International Space Agency Corporation.

Here are the 2013 Officers of the Nigeria ISA Society:

Mr. Ayodele Onibudo

President - Nigeria ISA Society

Profile: <http://ng.linkedin.com/pub/ayodele-onibudo/26/b30/90a>

Email: ayodele.onibudo@international-space-agency.us

Mr. Psalm Okemson

Vice President – Nigeria ISA Society

Profile: <http://ng.linkedin.com/pub/psalm-okemson/2b/445/216>

Email: psalm.okemson@international-space-agency.us

Mr. Oniosun Temidayo Isaiah

Secretary - Nigeria ISA Society

Profile: <http://ng.linkedin.com/in/oniosuntemidayoisaiah>

Email: oniosun.temidayo.isaiah@international-space-agency.us

Nigeria ISA Society Members - 5



Nigeria ISA Society Charter - Over all oversight of Nigerian Citizens interested in supporting or joining the International Space Agency in Nigeria. The Nigeria ISA Society is a Non-Profit, Non-Political, Non Governmental Society of Nigerian Citizens who are voluntary members, and serve no official position or office in the International Space Agency. The Nigeria ISA Society has as its Official Charter the supporting of the International Space Agency Vision, Mission, and Endeavors through Debate, Activism, Philanthropy, Common Association, by Citizens of Nigeria. The Nigeria ISA Society will also act as a catalyst and enabler for Nigerian Citizens to join the International Space Agency as Officers, Staff, Board Members, to engage in support of the International Space Agency Global Vision, Mission, Programs, Projects, Endeavors.

Iceland - ISA Society - International Space Agency Foundation

<http://www.linkedin.com/groups?gid=6512042>

Iceland ISA Society Is A Member Group of the International Space Agency Foundation which is a Division of the International Space Administration which is a Branch of International Space Agency Corporation.

Here are the 2013 Officers of the Iceland ISA Society:

Dr. Thorsteinn Olafsson

President - Iceland ISA Society

Profile: <http://is.linkedin.com/pub/thorsteinn-olafsson/43/aa5/633>

Email: thorsteinn.olafsson@international-space-agency.us

"Vacant"

Vice President – Iceland ISA Society

Profile: N/A

Email: @international-space-agency.us

"Vacant"

Secretary – Iceland ISA Society

Profile: N/A

Email: @international-space-agency.us

Iceland ISA Society Members - 4

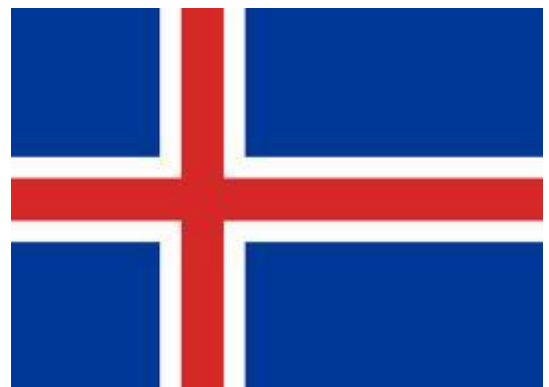

Iceland - ISA Society - Charter - Over all oversight of Icelandic Citizens interested in supporting or joining the International Space Agency in Iceland. The Iceland ISA Society is a Non-Profit, Non-Political, Non Governmental Society of Icelandic Citizens who are voluntary members, and serve no official position or office in the International Space Agency. The Iceland ISA Society has as its Official Charter the supporting of the International Space Agency Vision, Mission, and Endeavors through Debate, Activism, Philanthropy, and Common Association, by Citizens of Iceland. The Iceland ISA Society will also act as a catalyst and enabler for Icelandic Citizens to join the International Space Agency as Officers, Staff, and Board Members, and to engage in support of the International Space Agency Global Vision, Mission, Programs, Projects, and Endeavors

Iran - ISA Society - International Space Agency Foundation

<http://www.linkedin.com/groups?gid=5152204>

Iran ISA Society Is A Member Group of the International Space Agency Foundation which is a Division of the International Space Administration which is a Branch of International Space Agency Corporation.

Here are the 2013 Officers of the Iran ISA Society:

Mr. Soheil Salimi

President - Iran ISA Society

Profile: <http://ir.linkedin.com/pub/soheil-salimi/61/8b6/388>

Email: soheil.salimi@international-space-agency.us

Ms. Nilufar Pilghush

Vice President - Iran ISA Society

Profile: <http://ir.linkedin.com/pub/nilufar-pilghush/37/151/56b>

Email: nilufar.pilghush@international-space-agency.us

"Vacant"

Secretary - Iran ISA Society

Profile: N/A

Email: @international-space-agency.us

Iran ISA Society Members - 3



Iran - ISA Society - Charter - Over all oversight of Iranian Citizens interested in supporting or joining the International Space Agency in Iran. The Iran ISA Society is a Non-Profit, Non-Political, Non Governmental Society of Iranian Citizens who are voluntary members, and serve no official position or office in the International Space Agency. The Iran ISA Society has as its Official Charter the supporting of the International Space Agency Vision, Mission, and Endeavors through Debate, Activism, Philanthropy, and Common Association, by Citizens of Iran. The Iran ISA Society will also act as a catalyst and enabler for Iranian Citizens to join the International Space Agency as Officers, Staff, and Board Members, to engage in support of the International Space Agency Global Vision, Mission, Programs, Projects, Endeavors.

Other Official ISA Public Groups -&- ISA National Societies On LinkedIn

International Space Agency (ISA) Organization

<http://www.linkedin.com/groups?gid=4852590>

Candidates for ISA Board of Advisors

<http://www.linkedin.com/groups?gid=4864055>

Students for International Space Agency

<http://www.linkedin.com/groups?gid=4887928>

International SETI, Astrobiology, Exobiology (SAE) Program

<http://www.linkedin.com/groups?gid=4852658>

Candidates for ISA Board of Directors

<http://www.linkedin.com/groups?gid=4864049>

Candidates for ISA Officers / Personnel / Staff

<http://www.linkedin.com/groups?gid=4864061>

International Mars Exploration (IME) Program

<http://www.linkedin.com/groups?gid=4852620>

International Lunar Exploration (ILE) Program

<http://www.linkedin.com/groups?gid=4852628>

International Space Agency Foundation

<http://www.linkedin.com/groups?gid=4952460>

Spain - ISA Society

<http://www.linkedin.com/groups?gid=4917879>

Japan - ISA Society

<http://www.linkedin.com/groups?gid=4954294>

Bolivia - ISA Society

<http://www.linkedin.com/groups?gid=4921327>

Canada - ISA Society

<http://www.linkedin.com/groups?gid=4954491>

France - ISA Society

<http://www.linkedin.com/groups?gid=4916109>

Hungary - ISA Society

<http://www.linkedin.com/groups?gid=4954501>

New Zealand - ISA Society

<http://www.linkedin.com/groups?gid=4985120>

Turkey - ISA Society

<http://www.linkedin.com/groups?gid=4954308>

Australia - ISA Society

<http://www.linkedin.com/groups?gid=4916045>

Mexico - ISA Society

<http://www.linkedin.com/groups?gid=4956488>

China - ISA Society

<http://www.linkedin.com/groups?gid=4916051>

Germany - ISA Society

<http://www.linkedin.com/groups?gid=4916095>

Note: In 2013 & 2014 Malicious Provocators, Criminals, and Infiltrators Hacked and Sabotaged these ISA LinkedIn Sites. LinkedIn Email Accounts were Compromised and False Emails Where Circulated

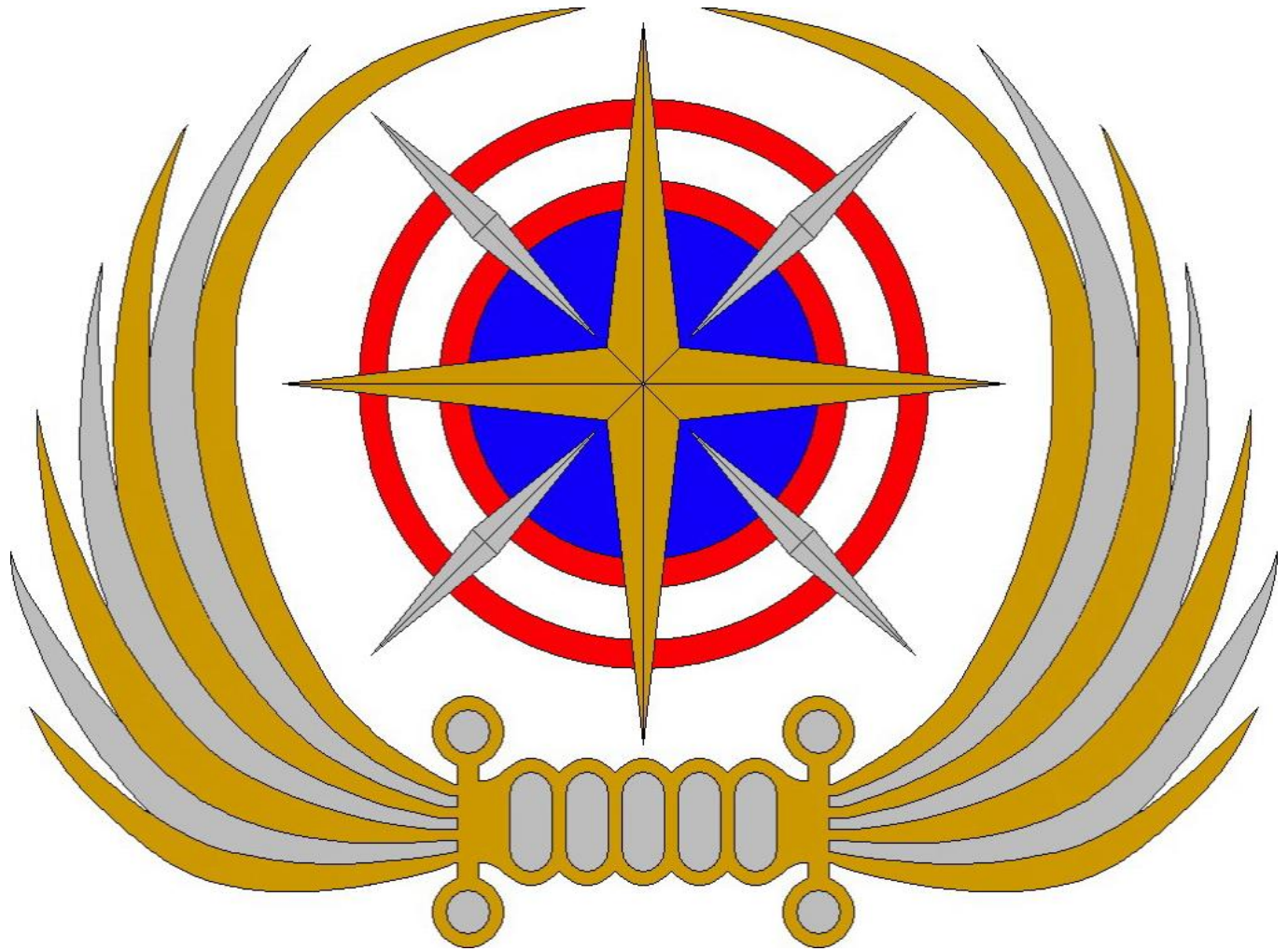

International Space Agency, ISA
International Space Administration
Founded In 1986 -&- Incorporated In 1990
Presently Seeking International Treaty -&- Charter Status

2013 - PROPOSAL

INTERNATIONAL SPACE ACADEMY “THE SPACE ACADEMY”

The International Space Academy “The Space Academy” Is An Academic, Physical Fitness, and Leadership Training Institution, Which Has A Primary Function Of Providing Highly Trained And Capable Space Operations, Scientific, Technical Leaders And Personnel To The International Space Agency, And Its Member States And Organizations; And As A Secondary Function, An Academic Training Institution To The Global Space Community And Global Space Sectors. The International Space Academy “The Space Academy” Is A Division Of The International Space Agency Organization.



International Space Agency , I.S.A. International Space Administration

PURPOSE: International Space Academy will Educate, Train, and Prepare Future International Leaders, Space Personnel, and Global Society, for the Exploration, Development and Colonization of our Solar System, and the Infinite Spaces of the Next Great Human Frontier, SPACE. The International Space Academy will Provide to the Member Nations and Organizations of the International Space Agency, and its Agents, Contractors, and Approved Individuals; Entrance into the Following Academic and Training Programs :

- **International Space Academy** - Administration, Professors, General Staff
- 2, 4, 6 year - Training Programs – International Space Academy **Officer Training** - “Commissioned Officers -&- Officer Cadets”
- 2, 4, 6 year - Training Programs – International Space Academy **NCO Training** - “Non-Commissioned Officers -&- NCO Cadets”
- 2, 4, 6 year - Training Programs – International Space Academy **Enlisted Training** - “Enlisted Personnel -&- Recruits” Enlisted Training
- 2, 4, 6 year - Training Programs – International Space Agency
- 2, 4, 6 year - University Courses & Classes:

International Space Agency - “Internal Personnel Training Programs”

(Diplomatic) , (International Space Agency Private) , (General Public)

BENEFITS: To provide highly trained and capable space operations, scientific, technical leaders and personnel to the International Space Agency, and its member states and organizations; and as a secondary function, to operate as an academic training “University” institution to the global space community, global space sectors, and the general public globally.

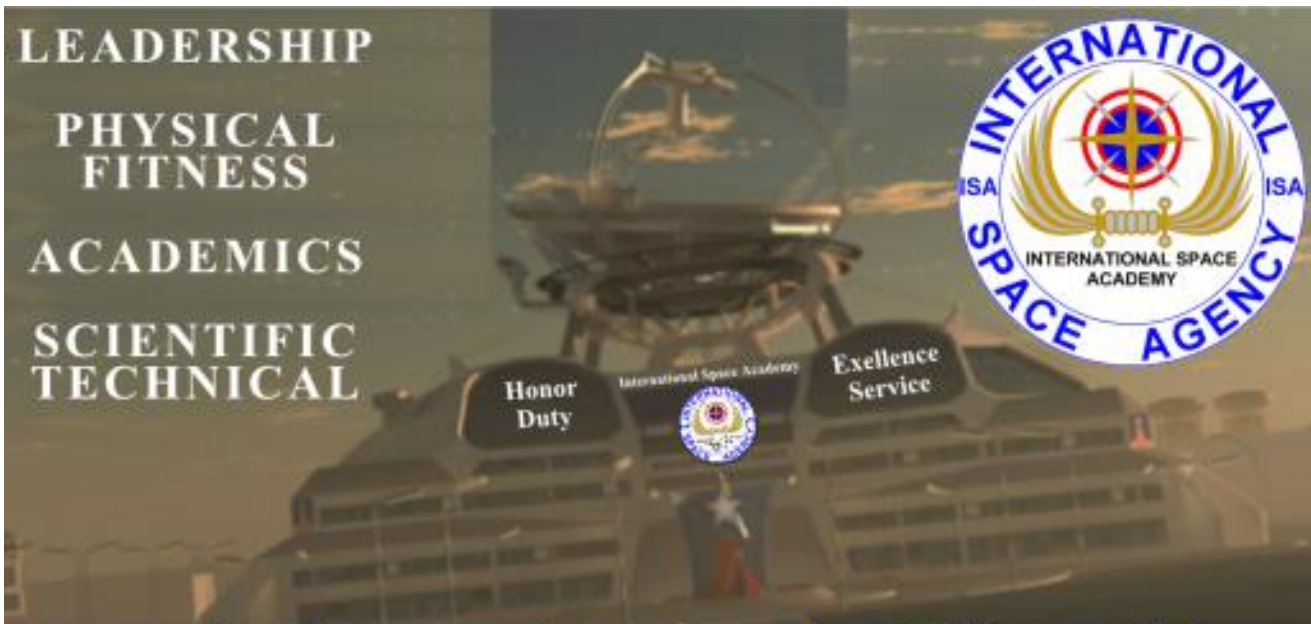

C. General Information



International Space Academy

Project Title:	International Space Academy "The Space Academy"
Brief Project Description:	The International Space Academy "The Space Academy" Is An Academic, Physical Fitness, and Leadership Training Institution, Which Has A Primary Function Of Providing Highly Trained And Capable Space Operations, Scientific, Technical Leaders And Personnel To The International Space Agency, And Its Member States And Organizations; And As A Secondary Function, To Operate As An Academic Training "University" Institution To The Global Space Community And Global Space Sectors. The International Space Academy "The Space Academy" Is A Division Of The International Space Agency Organization.
Prepared By:	Mr. Rick R. Dobson, Jr. - United States - Chairman, CEO, Founder, International Space Agency
Date:	4th of October, 2013

D. Project Objectives:

PURPOSE: To Educate, Train, and Prepare the Future International Leaders, Space Personnel, and Global Society, for the Exploration, Development and Colonization of our Solar System, and the Infinite Spaces of the Next Great Human Frontier, SPACE.

CAPABILITY: Specific Areas of Mission & Operations & Management Authority:

The International Space Academy will Provide to the Member Nations and Organizations of the International Space Agency, and its Agents, Contractors, and Approved Individuals; Entrance into the Following Academic and Training Programs :

- International Space Academy – Administration, Professors, and General Staff
- 2, 4, 6 year - Training Programs – International Space Academy “Commissioned Officers – Officer Cadets” Officer Training
- 2, 4, 6 year - Training Programs – International Space Academy “Non-Commissioned Officers – NCO Cadets” NCO Training
- 2, 4, 6 year - Training Programs – International Space Academy “Enlisted Personnel – Recruits” Enlisted Training
- 2, 4, 6 year - Training Programs – International Space Agency “Internal Personnel Training Programs”
- 2, 4, 6 year - University Courses & Classes: (Diplomatic) , (International Space Agency Private) , (The General Public)
- University & College & High School : (Summer Camps & Special Programs For Young Adults & Youth)
- To Support, Host, and Enable International Space Conferences, Meetings, and Events.
- Seek Support From: National Naval Academies Programs Globally “Submarine Communities In Particular”, National Space Agency Astronaut/Cosmonaut Training Programs Globally, and Private Commercial Payload & Technology Programs Globally, which will be sought out for Assistance, Support, Collaboration, Cooperation, and Joint Training & Operations Endeavors
- To engage and network with Universities, Colleges, Academic Institutions, and Scientific & Research Organizations Globally.

BENEFITS: To Provide Highly Trained And Capable Space Operations, Scientific, Technical Leaders And Personnel To The International Space Agency, And Its Member States And Organizations; And As A Secondary Function, To Operate As An Academic Training “University” Institution To The Global Space Community, Global Space Sectors, and the General Public.

FUNDING: A Single or Combined Grant or Donation in the sum of Three Million U.S. Dollars (\$ 3,000,000) is sought, to fund a “Start Up” Perpetual Space Sector Academic Training Academy and Programs, and Administrative and Educational Operations, and to obtain/secure key Space Technology, Science, and Administration Educators; and Academic, Technical, Language, Physics, Mathematics, Scientific, Engineering, Computer, Physical Fitness, and numerous other specialties, disciplines, and fields Professors, Administrators, Personnel, as well as Facilities, Equipment, and Materials required to build, organize, and operate an **International Space Academy and Programs**. This funding will provide the initial Main Facilities & Property, and Staffing & Operations for 2 to 3 years start up, thereafter, Cadet & Student Fees, Conference & Meeting Fees, and Research Grants will fund ongoing operations.

International Space Academy Main Facility / Headquarters



INTERNATIONAL
SPACE ACADEMY

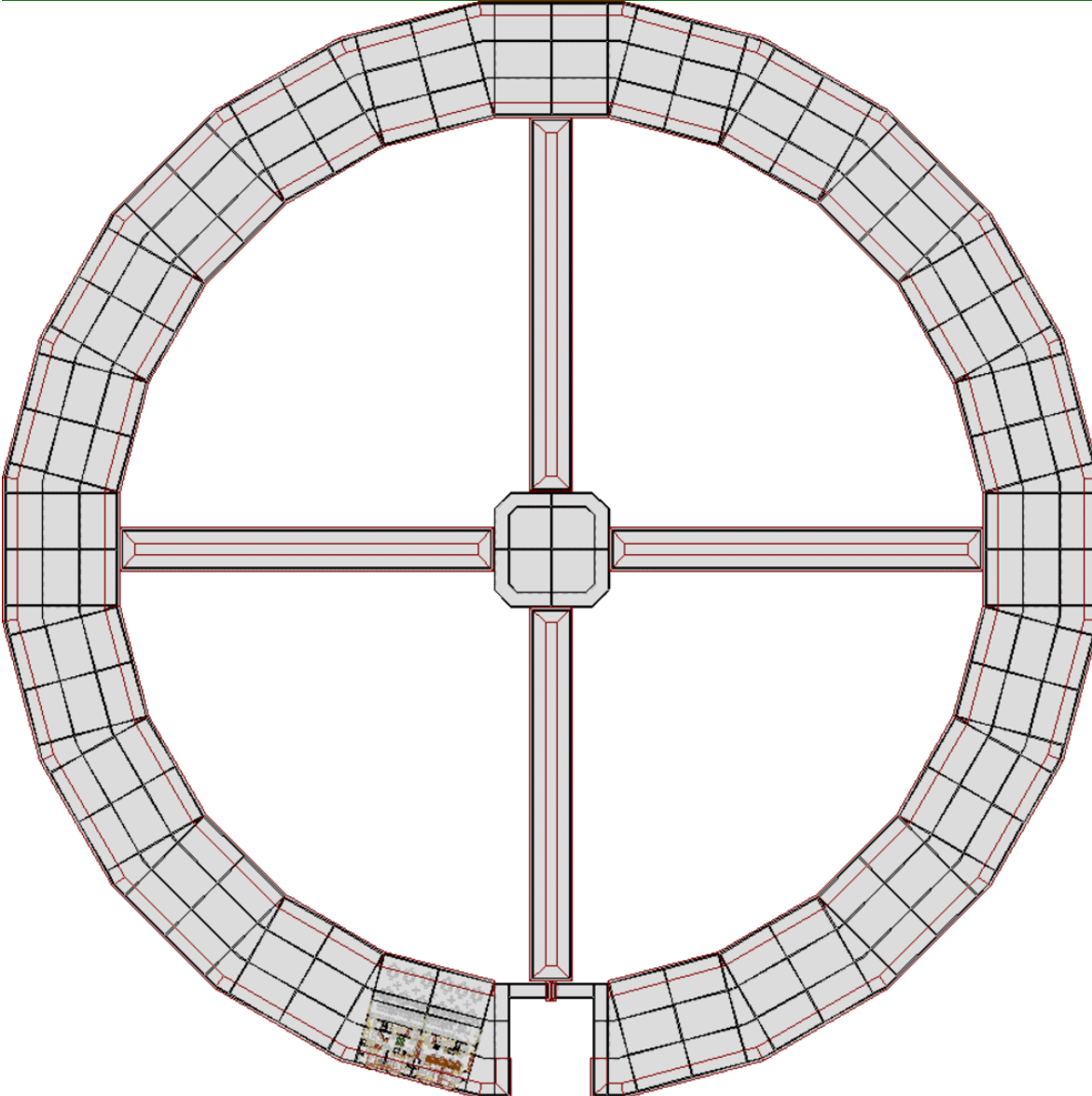
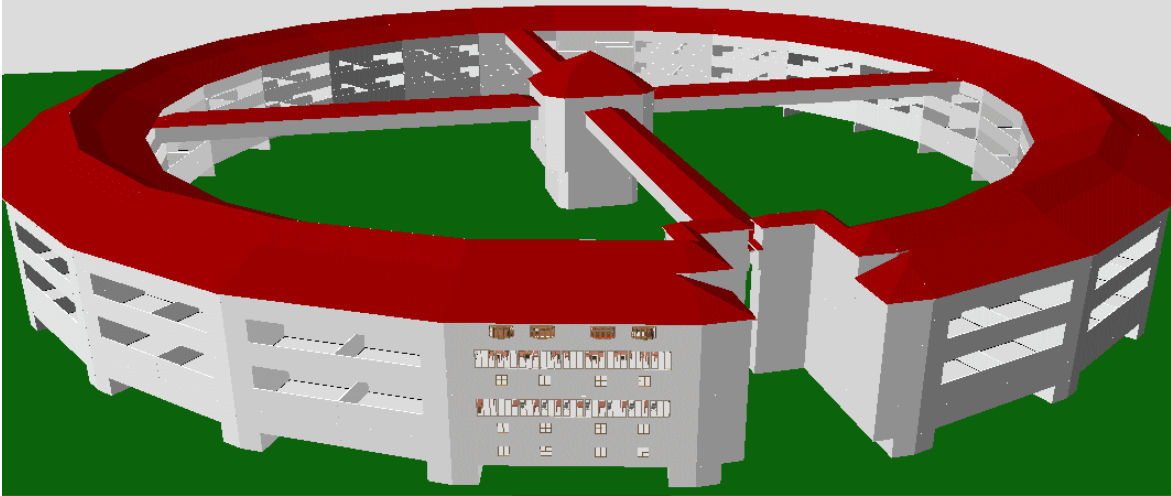

- CADET
DORM
ROOMS**
- CLASS
ROOMS**
- OFFICER
& STAFF
QUARTERS**
- ADMIN AND
PROFESSORS
OFFICES**
- LIBRARY**
- LABS**
- CENTRAL
COMPUTER
CORE**
- SHOPS**
- THEATER**
- ATHLETIC
FACILITIES**
- FOOD
SERVICES**
- LAUNDRY
FACILITIES**
- UTILITIES
SYSTEMS**

INTERNATIONAL SPACE ACADEMY



TRADEMARK -& COPYRIGHT
1986 TO 2017
ALL RIGHTS ARE RESERVED

CADET TRAINING SHIP PERSONNEL

256 - CADET'S

- 2 - OFFICER'S
- 4 - NCO'S
- 8 - CREW

- 4 - COOK'S
- 4 - PROFESSOR'S
- 2 - LIBRARIANS
- 2 - NURSE'S
- 2 - SECURITY
- 2 - I.T. TECH'S
- 2 - ENGINEER'S
- 2 - PLUMBER'S
- 2 - ELECTRICIAN'S
- 2 - AUTO MECHANIC'S
- 2 - HEAT & A/C TECH'S
- 2 - PHYSICAL FITNESS TRAINERS
- 2 - TAILORS -&- LAUNDRY TECH'S

CADET "SHIP" BUILDING HOUSING -&- TRAINING FACILITY

NOTE: Each "SHIP" Building will be totally self-contained and independant from all other "SHIP" Buildings on the International Space Academy Campus.

- 1 - POWER
- 2 - WATER
- 3 - SEWER
- 4 - HEATING
- 5 - COOLING
- 6 - AIR QUALITY
- 7 - FIRE SUPPRESSION
- 8 - COMPUTERS & COMMUNICATIONS

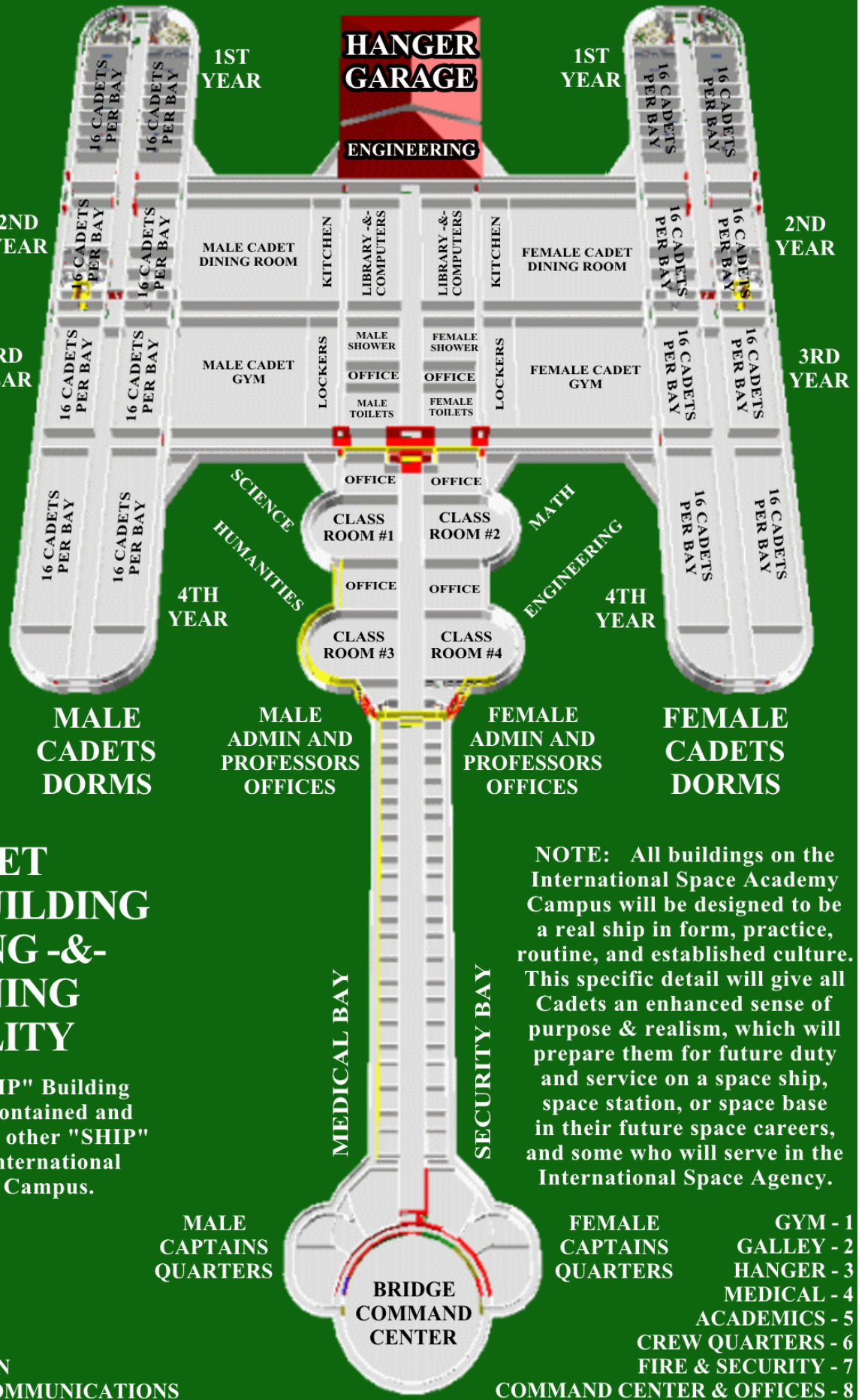

NOTE: All buildings on the International Space Academy Campus will be designed to be a real ship in form, practice, routine, and established culture. This specific detail will give all Cadets an enhanced sense of purpose & realism, which will prepare them for future duty and service on a space ship, space station, or space base in their future space careers, and some who will serve in the International Space Agency.

MALE CAPTAINS QUARTERS

FEMALE CAPTAINS QUARTERS

- GYM - 1
- GALLEY - 2
- HANGER - 3
- MEDICAL - 4
- ACADEMICS - 5
- CREW QUARTERS - 6
- FIRE & SECURITY - 7
- COMMAND CENTER & OFFICES - 8

International Space Agency (I.S.A.) International Space Academy

LEADERSHIP

PHYSICAL
FITNESS

ACADEMICS

SCIENTIFIC
TECHNICAL



Honor
Duty

International Space Academy

Excellence
Service



The International Space Academy Is An Academic & Physical Fitness & Leadership Training Institution , Which Has A Primary Function Of Providing Highly Trained And Capable Space Operations, Technology, and Scientific Leadership And Personnel To The International Space Agency (ISA), And Its Member States And Organizations ; And As A Secondary Function , To The Global Space Community And International Space Sectors. International Space Academy Is A Division Of The I.S.A. Organization.



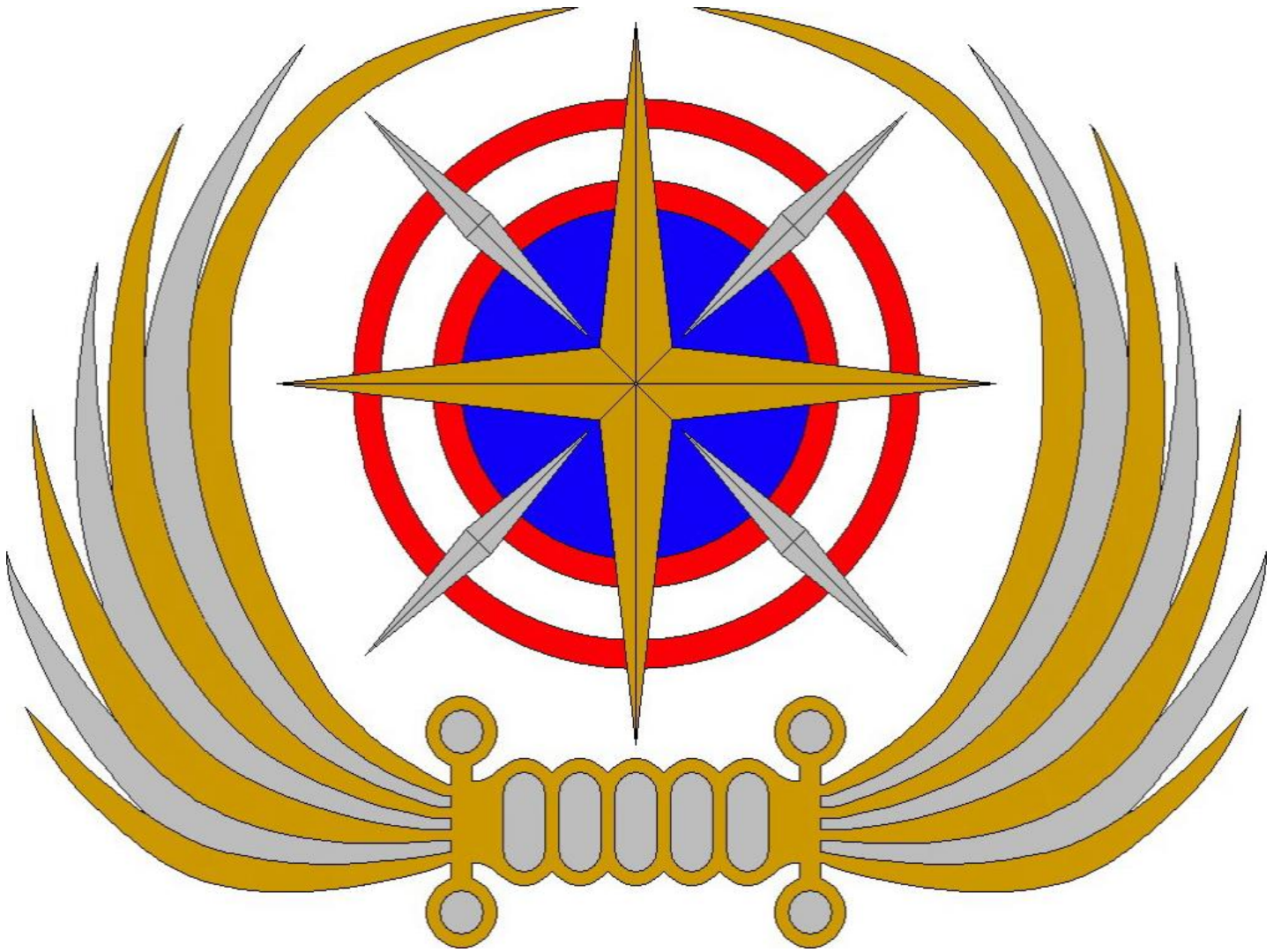

International Space Agency, ISA

International Space Administration

Founded In 1986 -&- Incorporated In 1990

Presently Seeking International Treaty -&- Charter Status

2013 - PROPOSAL

**INTERNATIONAL SPACE NEWS
(I.S.N.) ORGANIZATION / OFFICE**

I. S. N.

A Division & Service of the International Space Agency
TRADEMARK -&- COPYRIGHT - 1990 TO 2004
ALL RIGHTS ARE RESERVED

PROVIDING UNBIASED
FAIR -&- ACCURATE
GLOBAL SPACE
-&- SCIENTIFIC
INFORMATION
REPORTING
SERVICES
NEWS



INTERNATIONAL
SPACE NEWS
ORGANIZATION



INTERNATIONAL SPACE NEWS (I.S.N.) ORGANIZATION

<http://www.international-space-news.org>

The International Space News Organization is a Division of the International Space Agency, I.S.A. and the purpose of the I.S.N. Organization is to provide unbiased, fair, and accurate updates, news, and information about human space endeavors & efforts from around the World. The I.S.N. Organization also operates under the public domains of World Space News (W.S.N.) and Global Space News (G.S.N.). It is the long term goal of I.S.N. to provide a wide range of Television, Radio, Internet, and Printed Media Outlets & Services, Globally. It is also the goal of I.S.N. to act as a neutral venue for National Space Agencies, Commercial & Private Space Organizations, Space Societies & Groups, and as well as an outlet for I.S.A. activities & Efforts.

I. S. N.

A Division & Service of the International Space Agency
TRADEMARK -&- COPYRIGHT - 1990 TO 2004
ALL RIGHTS ARE RESERVED

PROVIDING UNBIASED
FAIR -&- ACCURATE
GLOBAL SPACE
-&- SCIENTIFIC
INFORMATION
REPORTING
SERVICES
NEWS



INTERNATIONAL
SPACE NEWS
ORGANIZATION



I. S. N.

A Division & Service of the International Space Agency
TRADEMARK -&- COPYRIGHT - 1990 TO 2004
ALL RIGHTS ARE RESERVED

PROVIDING UNBIASED
FAIR -&- ACCURATE
GLOBAL SPACE
-&- SCIENTIFIC
INFORMATION
REPORTING
SERVICES
NEWS



INTERNATIONAL SPACE NEWS ORGANIZATION



INTERNATIONAL
SPACE AGENCY
I. S. A.



TELEVISION
INTERNET
RADIO
PRINT

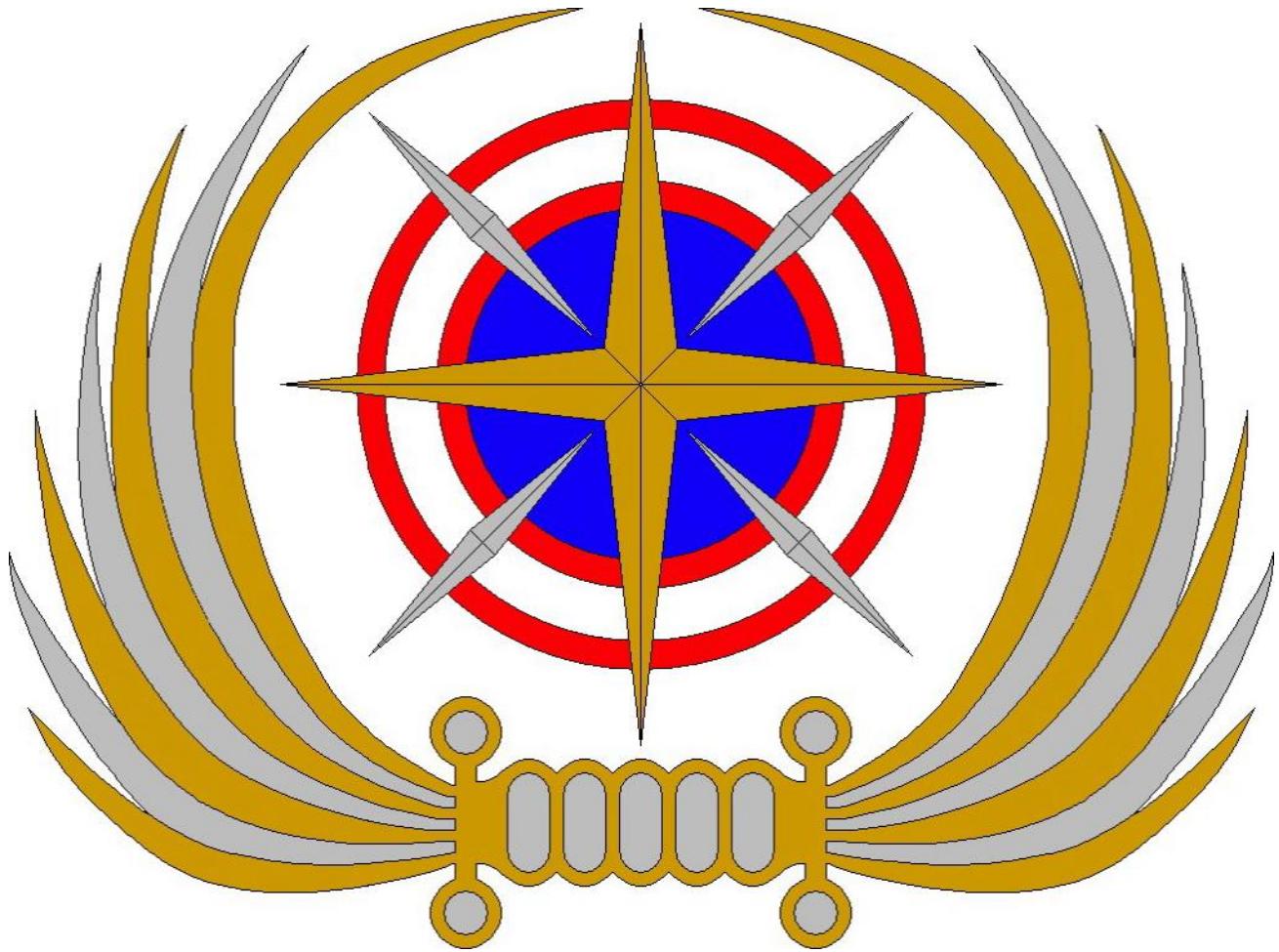

International Space Agency, ISA
International Space Administration
Founded In 1986 -&- Incorporated In 1990
Presently Seeking International Treaty -&- Charter Status

2013 - PROPOSAL

INTERNATIONAL SUPER COMPUTER PROGRAM

International Super Computer Center & Program Office

Data Computing & Storage for Global Space Technology, Space Science's, Astronomy, ISA Operations
International Collaboration, Cooperation, and Joint Efforts, by/for ISA Member States & Organizations
Cost Savings & Resource Preservation through utilization of Central International Data Base & Facility
Central & Secure Operating Environment for, Database's & Archive's, and Management & Personnel
Central Global Database & Archive's, Simulation's & Calculation's Processing, Hardware & Facilities



International Space Agency , I.S.A. International Space Administration

PURPOSE: The **International Super Computer Center & Program Office (ISCCPO)** will support and maintain a secure central international space sciences, astronomy, and space technology data base, and advanced computer simulation capabilities for advanced International Space Agency, ISA, and international, space technology programs, projects, missions, and advanced international space research & development activities. The **ISCCPO** will function as an important operational division, center, and program office of "**International Space Agency, ISA**" and will be a catalyst & enabler to facilitate & support all research & development, and space technology programs, and the central management of Computing Capabilities & Services and Supercomputer Facilities & Hardware that will be directly or indirectly supporting the vision and mission of the International Space Agency Organization; and its Operational Divisions, Departments, Centers, and Commands. **ISCCPO** will also be the command & control authority of the **International Super Computer Facility (ISCF)** and **International Super Computer Program Office (ISCP)**, and will include the collective personnel resources of **ISCCPO** Officers, Management, Technicians, and Personnel.



2013 Proposal - Operational & Programs Charter For The "International Super Computer Center & Program Office" (I.S.C.C.P.O)

A. General Information



Project Title:	International Super Computer Center & Program Office (I. S. C. C. P. O)
Brief Project Description:	The ISCCPO will support and maintain a secure central international space sciences, astronomy, and space technology data base, and advanced computer simulation capabilities for advanced International Space Agency, ISA, and international, space technology programs, projects, missions, and advanced international space research & development activities.
Prepared By:	Mr. William Kraemer - United States Director , International Super Computer Center & Program Office, International Space Agency, ISA Mr. Joshane Kelsy - India Assistant Director , International Super Computer Center & Program Office, International Space Agency, ISA Mr. Rick R. Dobson, Jr. - United States - Chairman, CEO, Founder , International Space Agency, ISA
Date:	4th of October, 2013

B. Project Objectives:

PURPOSE: The **International Super Computer Center & Program Office (ISCCPO)** will function as an important operational division, center, and program office of "**International Space Agency, ISA**" and will be a catalyst & enabler to facilitate & support all research & development, and space technology programs, and the central management of Computing Capabilities & Services and Supercomputer Facilities & Hardware that will be directly or indirectly supporting the vision and mission of the International Space Agency Organization; and its Operational Divisions, Departments, Centers, and Commands. **ISCCPO** will also be the command & control authority of the **International Super Computer Facility (ISCF)** and **International Super Computer Program Office (ISCCPO)**, and will include the collective personnel resources of **ISCCPO** Officers, Management, Technicians, and Personnel.

CAPABILITY: Specific Areas of Mission & Operations & Management Authority:

- Data Computing & Storage for Global Space Technology, Space Science's, Astronomy, and ISA Operations
- International Data & Computing Collaboration, Cooperation, and Joint Efforts, by/for ISA Member States & Organizations
- Cost Savings & Resource Preservation through Utilization of a Central International Data Base, Software, Hardware, and Facility
- Central & Secure Virtual Operating Environment, Database's & Archive's, and Management & Personnel
- Central International Database & Archive's, Simulation's & Calculation's Processing, Hardware & Facilities.
- Verbal & Digital Multi-Language Interface Capabilities "Voice Commands & Teletype/Keyboard & Digital"
- Language Translation Capability "Universal Translator System"
- Advanced State Of The Art - Data Storage Systems, User Friendly Program "Software" Architecture, Computer/Human Interfaces
- Advanced Scientific & Technology Simulations & Calculations Capabilities
- Advanced Display & 3D Projection Systems and Virtual Reality Capabilities
- Dedicated Point to Point Laser, Microwave, and Satellite Communications Network to International Space Agency Infrastructure.
- Hardened & Secure Deep Underground Facility for Housing All Primary ISCCPO Data, Software, Equipment, and Personnel
- Research & Development of Artificial Intelligence Systems and Durable Computer Systems Suitable for Space Environments

BENEFITS: The **ISCCPO** will ensure the smooth functioning of the **ISCF** Program & **ISCO** Operations, and will streamline & combine many selected & approved international, multi-national, and national space science & technology data bases & archives into one unified and easy to access and use international data base & archive. The **ISCCPO (ISCF & ISCO)** Project will create a "**First Of Its Kind**"; permanent & secure International Super Computer Facility & Database and Archive's, with Dedicated Staff, to maintain International Space Agency and selected, approved, and authorized international space technology & scientific databases & archives, and to provide advanced simulation & computing ability for the International Space Agency Organization and international space technology & scientific research & development programs. Security, both physical & systems operations, will protect **ISCF** databases & archives, and allow the information to be segregated or shared as the International Space Agency, and **ISCF**, Member Nations, NGO's, and Data Originator's may so desire or authorize, or as jointly approved. The benefits to the advancement of scientific knowledge of space, and the opening & utilization of the space frontier by humanity, as a result of the success of the **ISCF** project will be tremendous, and will surely become an invaluable resource to Humanity of Earth.

FUNDING: A Single or Combined Grant or Donation in the sum of Seven Million U.S. Dollars (\$ 7,000,000) is sought, to fund a "Start Up" Perpetual Research, Development, and Operations Program, to obtain/secure key Scientific, Engineering, Computer Personnel, Facilities, Equipment, and Materials required to build, organize, and operate an **International Super Computer Facility & Program**.

International Space Agency

International Super Computer Facility, ISCF, Project

NOTICE: CLASSIFIED & PRIVATE INFORMATION

Purpose: The ISCF will support and maintain a secure central international space science, astronomy, and space technology data base, and advanced computer simulation capabilities for advanced ISA, and international, space technology programs, missions, research and development.

Background: A major US computer company is interested in assisting the ISA with ISCF, and an Omaha based computer consulting and management company has now formally joined the International Space Agency in the development of an International Super Computer Facility, ISCF. Also, ongoing efforts are also underway to gain support and involvement of Admiral Ellis, and the USA Space Command, now STRATCOM, in Omaha, Nebraska to help develop the ISCF secure communications architecture, and to use and piggy back the existing US Government secure communications system in Omaha, Nebraska. The proposed location of the ISA, ISCF is presently Omaha, Nebraska. This, because of the strategic value of this location; and also from a security & economic point of view as well.

Benefits: The ISCF program will streamline and combine many selected and approved national space science and technology data bases into one unified and easy to use international data base. The ISCF Project will create a first of its kind, permanent and secure International Super Computer Facility, with Staff, to maintain ISA and selected international space scientific databases, and to provide advanced computing ability for ISA and international space technology and scientific research and development programs. Security, both physical and systems operations, will protect ISCF data, and allow the information to be segregated or shared as the ISA, and ISCF, Member Nations, NGO's, and as Data Originator's may so desire, or as jointly approved. The benefits to the advancement of scientific knowledge of space, and the opening and utilization of the space frontier by humanity, as a result of the success of the ISCF project will be tremendous, and will surely become an invaluable global asset, to humanities future in space.

Define ISCF Requirements ?

- 1) High security systems access and operations; and physical security.
- 2) Closed loop transmission systems and secure servers.
- 3) International language translation ability.
- 4) The ability to compile various international, national, NGO's Space Science Data Bases into a Single Standardized and easy to use ISA, ISCF, data base.
- 5) Multilevel access for all ISCF operations and data access systems. System segregated access architecture profile: ISA, International, National, NGO's, Universities, Corporations, Individuals, ect.



International Space Agency , I.S.A.
International Space Administration
 Founded In 1986 -&- Incorporated In 1990
 Presently Seeking International Treaty -and- Charter Status

2013 - PROPOSAL INTERNATIONAL SUPER COMPUTER CENTER (I.C.C.P.) PROGRAM / OFFICE



World Class Facilities & Technology & Software

**World Class Operations
 Leadership & Personnel**



World Class Simulations



**World Class Data Base
 At Finger Tip Instant
 On Demand Access**



**Secured & Controlled Access
 To World Class Data Bases
 And Computing Capabilities**

International Space Agency - I.S.A. International Space Administration



**International Super Computer
Center -&- Programs Office**



ISCCPO



World Class Facilities & Technology & Software

**World Class Operations
Leadership & Personnel**



World Class Simulations

**World Class Data Base
At Finger Tip Instant
On Demand Access**

**Secured & Controlled Access
To World Class Data Bases
And Computing Capabilities**

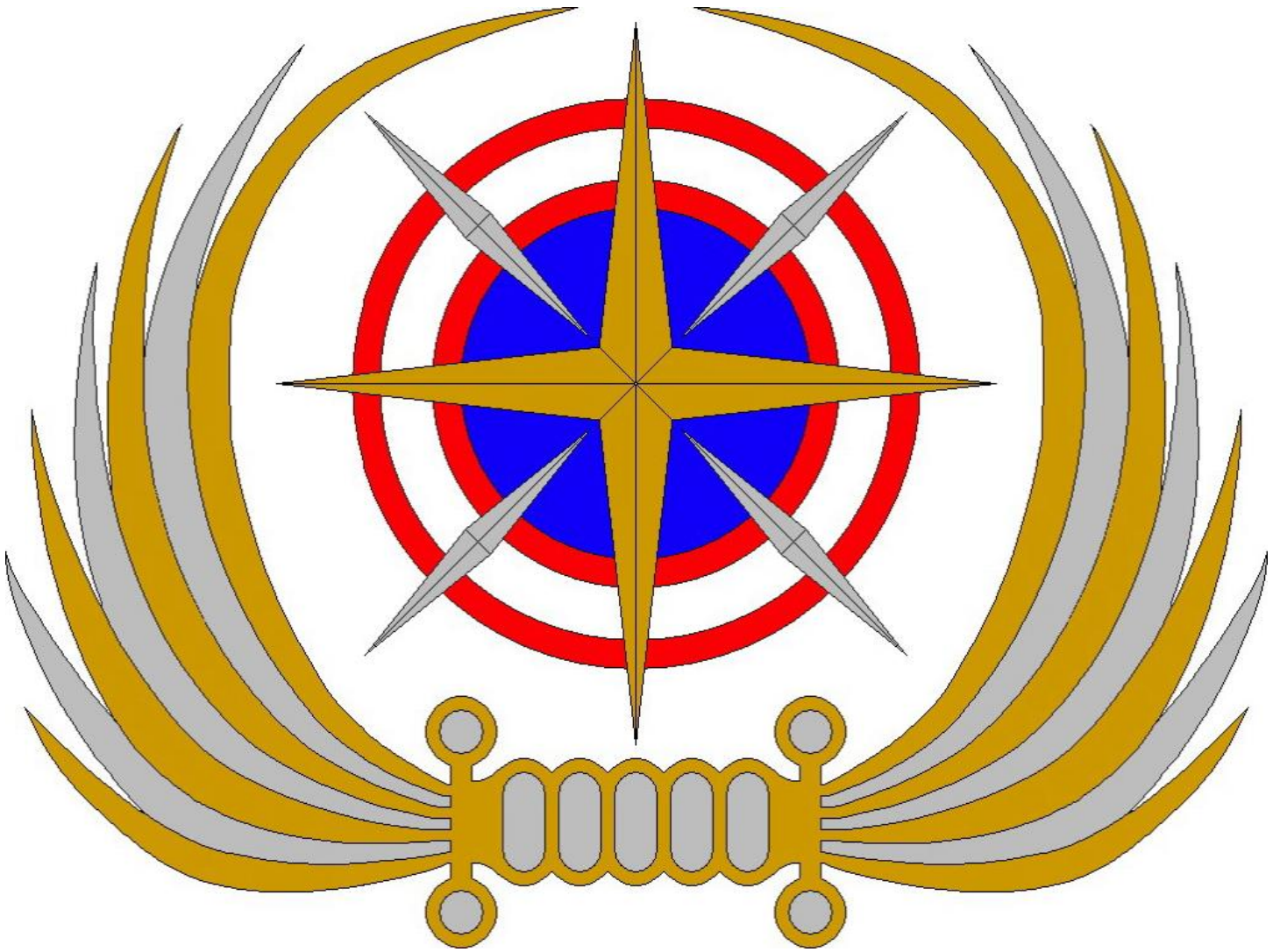

International Space Agency, ISA

International Space Administration

Founded In 1986 -&- Incorporated In 1990

Presently Seeking International Treaty -&- Charter Status

2013 - PROPOSAL

INTERNATIONAL SPACE OPERATIONS

CENTER (I.S.O.C.) OFFICE



International Space Agency , I.S.A.
International Space Administration
 Founded In 1986 -&- Incorporated In 1990
 Presently Seeking International Treaty -and- Charter Status

2013 - PROPOSAL
INTERNATIONAL SPACE
OPERATIONS CENTER
(I.S.O.C.) OFFICE

International Space Operations Center

Earth Surface
Operations

Earth Orbital
Operations

Planetary / Moon
Operations

Space Fleet
Operations

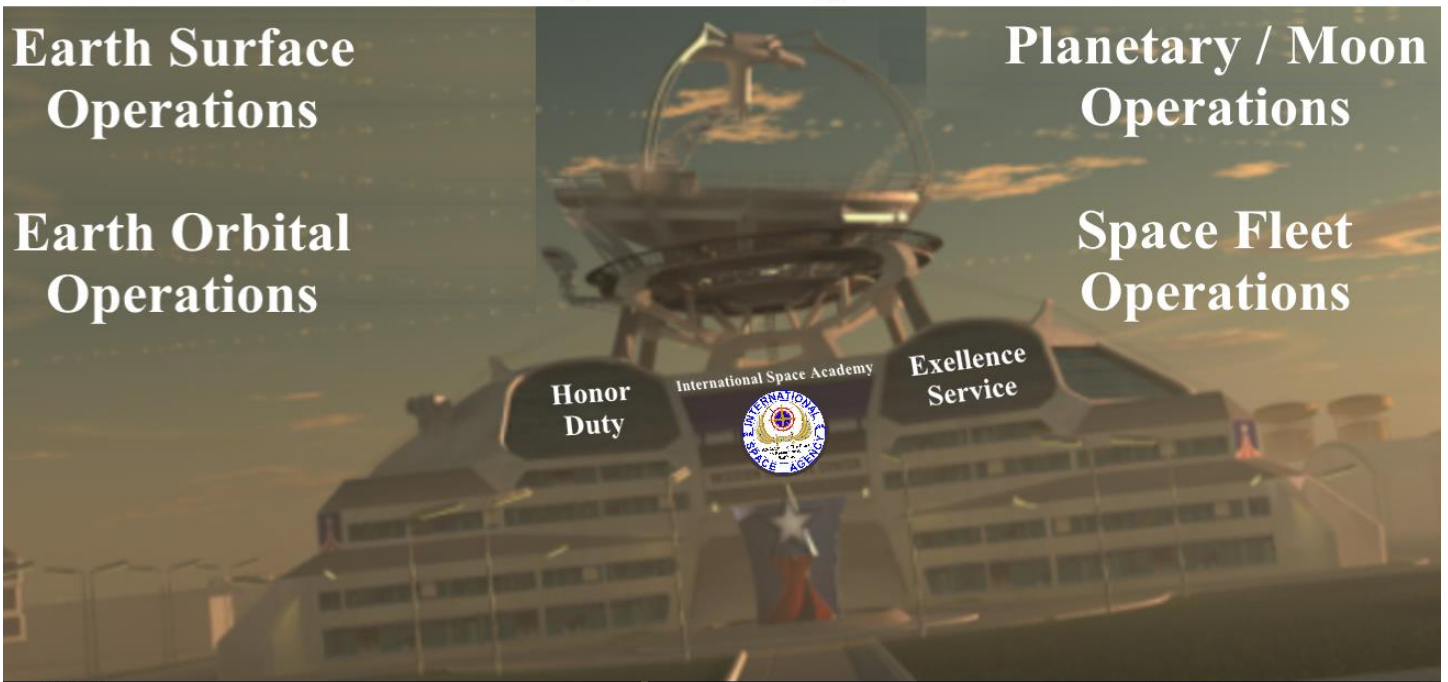

EARTH
ORBITAL
COMMAND

**International
Earth Orbital
Infrastructure
(I.E.O.I.)
Program**

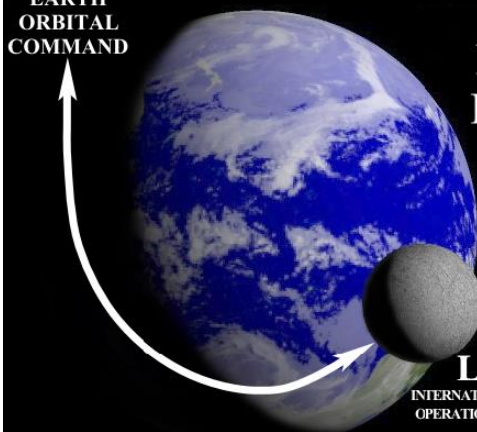

EARTHS
MOON
LUNA
INTERNATIONAL LUNA
OPERATIONS CENTER



MARS

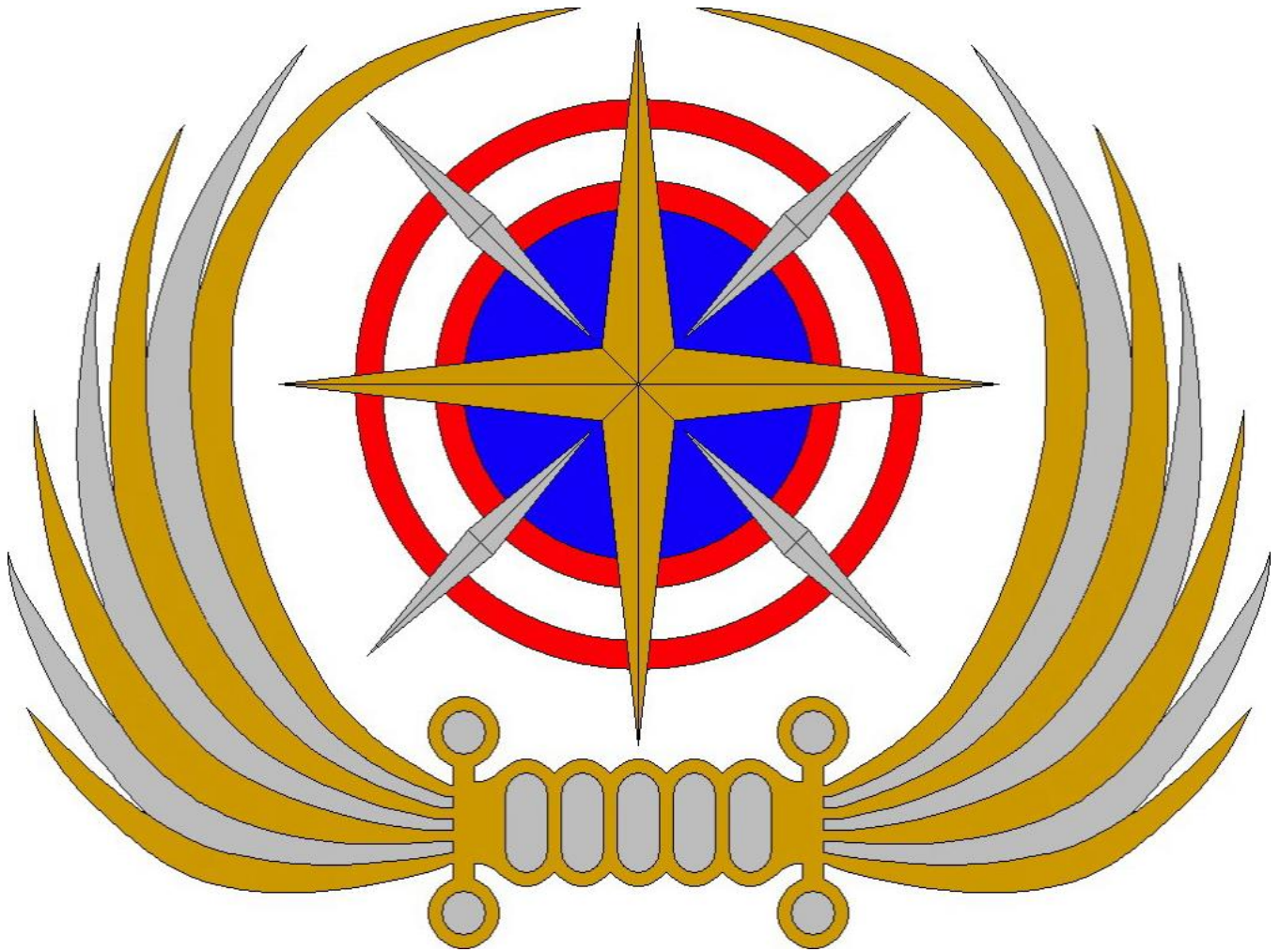

International Space Agency, ISA

International Space Administration

Founded In 1986 -&- Incorporated In 1990

Presently Seeking International Treaty -&- Charter Status

2013 - PROPOSAL

**INTERNATIONAL SOLAR
SYSTEM EXPLORATION
(I.S.E.) PROGRAM / OFFICE**



International Space Agency , I.S.A. International Space Administration

PURPOSE: The International Solar System Exploration (I.S.E.) Program / Office will function as the Core/Central Knowledge and Expertise Base and Focal Point of Excellence and Standards for all Earths Solar System Infrastructure, Operations, Projects, Missions, and Programs of the International Space Agency, I.S.A.. It will be the Key Initiator, Enabler, Conduit, Promoter, and Organizational Instrument for all endeavors specifically related to the exploration, utilization, and human settlement and activities through out the Earths Solar System. This will include (but is not limited to) coordination of the mapping of Earths Solar System (initially planning robotic probes to map Earths Solar System, Google Maps is a good example of what I.S.A. should be looking to achieve.) to identify suitable landing sites, and possible locations for Bases and Facilities, planning and execution of Orbital Space Stations and Space Craft "Infrastructure" to shuttle Personnel, Supplies, Materials, and Equipment through out the Earths Solar System and Planets/Moons Orbit "to/from" Planets/Moons Surface; and various Surface/Subsurface activities & facilities on Planets/Moons/ Asteroids



E. General Information

Project Title:	International Solar System Exploration (I.S.E.) Program / Office (of the International Space Agency, I.S.A.)
Brief Project Description:	The I.S.E. Program / Office will, Firstly, Promote, Organize, Design, Build, Support, Operate, and Maintain all International Space Agency Infrastructure, Stations, Space Craft, Bases, Facilities, Vehicles, Assets, Personnel, Activities, Missions, Projects, and Programs in Earths Solar System ; and, Secondly to act as an Enabler, Bridge Head, and Focal Point for all National Space Agency and Private Tourism, Commercial, Scientific, and Mining activities in Earths Solar System , in achieving their Non-Military and Peaceful Civil Objectives and Endeavors, in regards to their own independent Earths Solar System activities and missions. The I.S.A. will be the Key Core/Central Administrator & Management, Quality Control & Safety, Search & Rescue, Medical & Health Services, Research & Development, Navigations & Communications, and Infrastructure & Assets umbrella organization through out Earths Solar System . The International Space Agency will provide the Core/Central Infrastructure, Personnel, and Operations in Earths Solar System , and all End Users will provide independently, or approved to be contracted through International Space Agency networks, all support services, materials, personnel, consumables, equipment for independent activities outside the direct control or charter of the International Space Agency. It's highly advised, that no Earth Government be allowed to have Sovereign control of Space, like Antarctica.
Prepared By:	Admiral, Rick R. Dobson, Jr. - United States - Director , International Solar System Explorations Program
Date:	20/10/2013

F. Project Objective:

Purpose: The **International Solar System Exploration (I.S.E.) Program / Office** will function as the Core/Central Knowledge & Expertise Base and Focal Point of Excellence & Standards for all **Earths Solar System** Infrastructure, Operations, Projects, Missions, and Programs of International Space Agency. It will be the Key Initiator, Enabler, Conduit, Promoter, and Organizational Instrument for all endeavors specifically related to the exploration, utilization, and human settlement & activities through out **Earths Solar System**. This will include (but is not limited to) coordination of the mapping of **Earths Solar System** (initially planning robotic missions to map **Earths Solar System**, Google Maps is a good example of what ISA should be looking to achieve.) to identify suitable exploration sites, and possible locations for Bases and Facilities through out **Earths Solar System**, planning and execution of Space Stations and Space Craft "Infrastructure" to shuttle Personnel, Supplies, Materials, and Equipment through out **Earths Solar System**.

Areas of Operations, Programs, and Missions Authority:

- Building a Knowledge & Expertise Base related to all things required for the Exploration, Utilization, Human Settlement.
- Researching & Planning Most Effective & Best Possible Locations to Enable Landings, Launch, Surface/Subsurface Activities.
- **Explore Possible Transportation Systems "from/to" Solar System to Earth / Solar System to Luna / Solar System to Mars**
 - Conventional Chemical Propulsion/Power Technologies / Nuclear "Fission & Fusion" Propulsion/Power Technologies
 - Ion Thrusters Propulsion Technologies / Solar Cell Based Propulsion/Power Technologies
 - Hybrid, Non-Conventional, and Closed Loop Propulsion/Power Technologies
- **Explore Possible Transportation Infrastructure and Systems "from/to" Planets/Moons Surface to Planets/Moons Orbit**
 - Conventional Chemical Propulsion/Power Technologies / Nuclear "Fission & Fusion" Propulsion/Power Technologies
 - Ion Thrusters Propulsion Technologies / Solar Cell Based Propulsion/Power Technologies
 - Hybrid, Non-Conventional, and Closed Loop Propulsion/Power Technologies
 - Electromagnetic Rail Launch & Recovery Systems, Mechanical Leverage Launch, Equatorial Space Elevator
- Soliciting & Selection of Suitable Government & Private End Users & Costumers for Robotic & Human Exploration & Activities.
- Design of suitable space craft, vehicles, and equipment for Robotic & Human Exploration & Activities
- **Design and Planning of Suitable Structures, Buildings, Facilities, and Utilities on the Surface & Subsurface.**
 - Personnel Living Quarters / Tourist & Hotel Accommodations / Special Purpose Accommodations & Facilities
 - Suitable Structures & Facilities to support a wide range of working and living requirements on the Surface & Subsurface.
 - Environmental structures & buildings to grow food and keep animal livestock for consumption, store & process water & waste.
 - Structures & Facilities to House: Environmental & Atmosphere, Heating & Cooling, Water & Waste, Systems & Infrastructure.
 - Structures & Facilities to House: Commercial & Industrial, Scientific & Research, Academic & Training, Infrastructure.
 - Structures & Facilities to House: Power Systems, Navigations Systems, Communications Systems, and Computer Systems.
 - Structures & Facilities to House: Medical & Health Services, Search & Rescue Services, and Security & Judicial Services
- Initial explorers will require laboratories in which to experiment with life support systems to enable humans to live through out **Earths Solar System**, Primary Focus of Materials & Personnel will be on Construction & Natural Resources Exploration /Utilization.

Benefits: The **International Solar System Explorations (I.S.E.) Program / Office** will be the Core/Center of Specialized Knowledge, Expertise, Excellence, Standards, Personnel, Space Stations, Space Craft, Vehicles, Equipment, Structures, Bases, Facilities, Programs, Projects, Missions, and Human Activities through out **Earths Solar System**, able to supply its Infrastructure, Resources, and Operations to National "Government & Civil" and Private Space Exploration Agencies, Organizations, Companies, Institutions, Foundations, Societies, and Private Individuals. Enabling them to Benefit Symbiotically, Collectively, and Co-Operatively on the Promotion, Planning, Building, Operation, and Maintenance of a Robust, Extensive, and Long Duration Transportation & Support Infrastructure "Out Side The National Domain or Capability", which is easily accessed, with all costs optimized, and enhanced and rapid technology development. The **International Solar System Explorations (I.S.E.) Program / Office** will work very closely with, and in tandem, with the **International Mars Explorations (I.M.E.) Program / Office** and **International Luna Explorations (I.L.E.) Program / Office** as all elements of these "**3**" **KEY I.S.A. Programs**, will collectively depend on each others existence to ensure overall broad program operation, advances & success.

Funding: Costs for all International Space Agency infrastructure & operations through out **Earths Solar System**, will be obtained primarily through a pay for use strategy "**Toll or Fee**" by all end users, whether they be National Governments or Non-Governmental Entities, Organizations, or Persons; and, augmented by approved Multi-National & Joint Programs Participants, Government & Private Grants, and Private Philanthropy. A proposed initial amount of (\$7 Billion) U.S. Dollars is sought for **ISE Program** start up funding.



International Space Agency , I.S.A.
International Space Administration
Founded In 1986 -&- Incorporated In 1990
Presently Seeking International Treaty -and- Charter Status

2013 - PROPOSAL

INTERNATIONAL SOLAR SYSTEM EXPLORATION (I.S.E.) PROGRAM / OFFICE

EARTH - LUNA - MARS - AND BEYOND

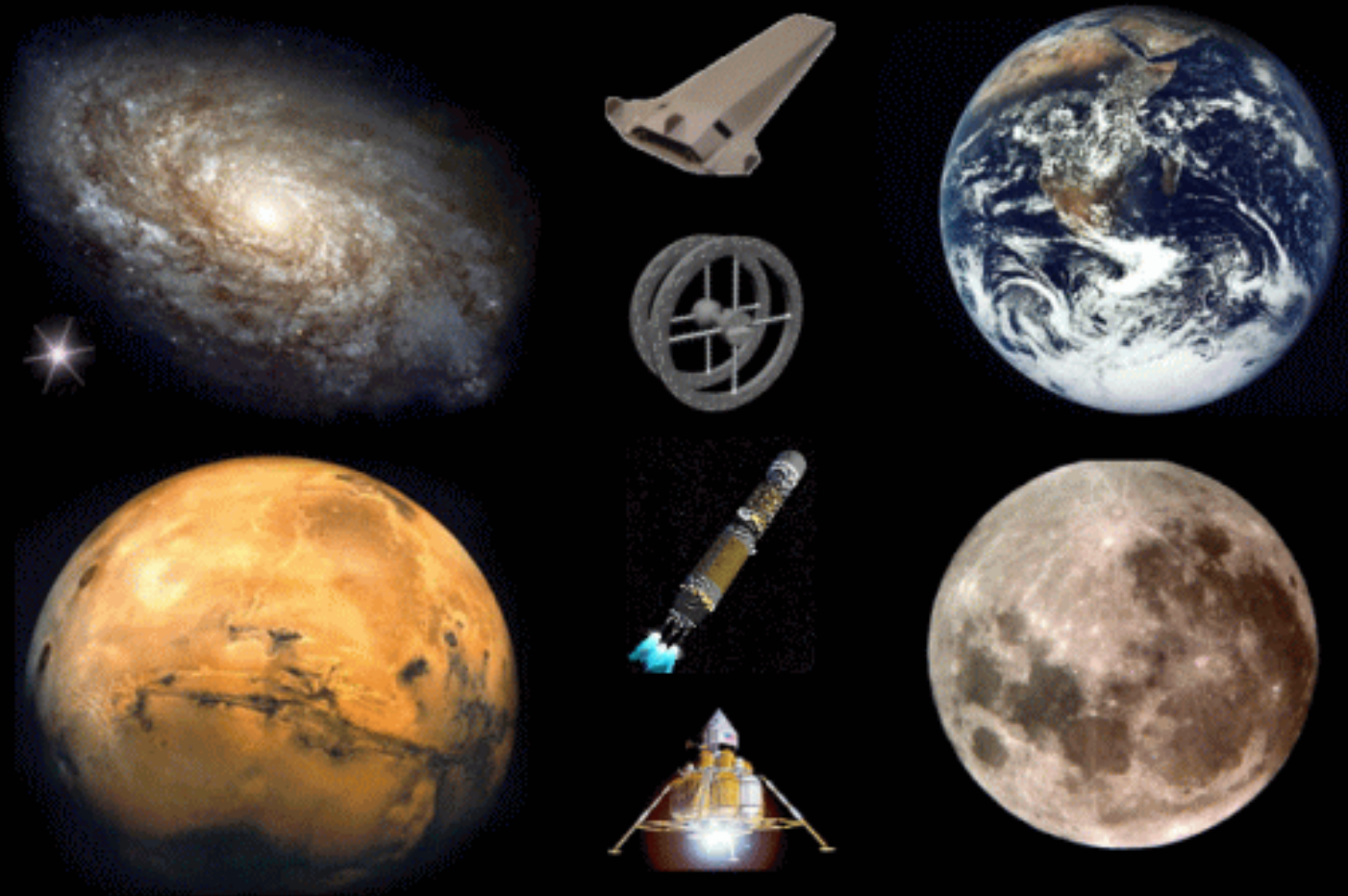

International Solar System Exploration (ISE) Program

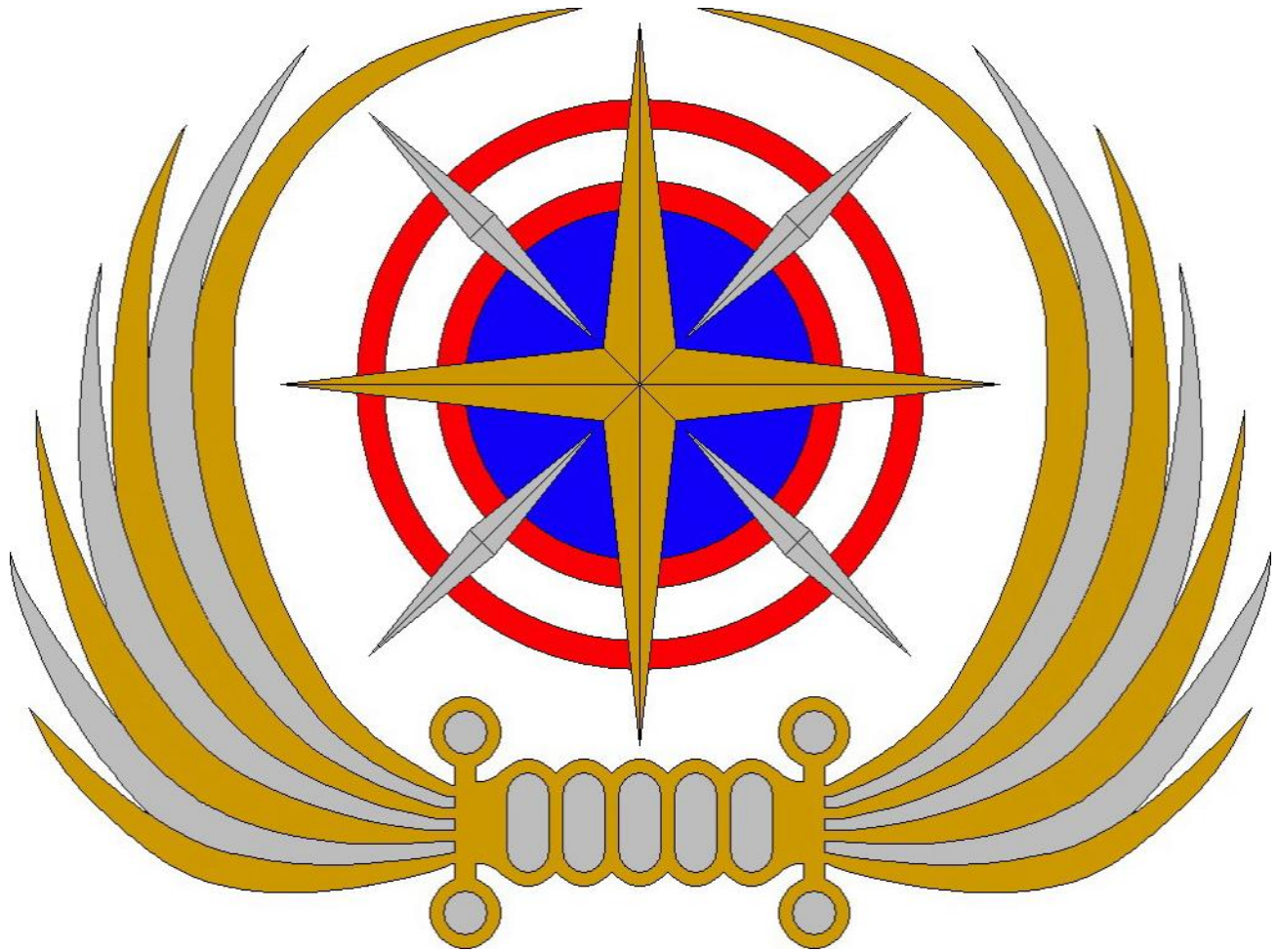

International Space Agency, ISA
International Space Administration
Founded In 1986 -&- Incorporated In 1990
Presently Seeking International Treaty -&- Charter Status

1988 - PROPOSAL

“TERRA MEGA INFERNO”

International Ground Based Vertical Tube Space Launch System
Using Multi Staged Gas Stream Vortex Injectors To Accelerate A Supersonic Gas Column Of

**Super High Pressure Steam Generated By Liquid Hydrogen Oxygen Combustion
To Propel A Single Stage Reusable Space Vehicle At High G's Into Earths Orbit.**



**International Space Agency , I.S.A.
International Space Administration**

PURPOSE: International Ground Based Vertical Tube Space Launch System, Using Multi Staged Gas Stream Vortex Injectors To Accelerate A Supersonic Gas Column Of, Super High Pressure Steam & Hot Gases Generated By Liquid Hydrogen Oxygen Combustion & Heat Conversion of Water to Steam, Up a Reinforced Concrete Launch Tube, To Propel a Single Stage Reusable Ballistic Space Vehicle "R.B.S.V." At High G's Into Earths Orbit. Very High Volume Launch Capacity at very low launch cost per pound. Projectiles "RBSV's" are launched in the very same way as a shell in a modern military cannon is fired down range, except the "RBSV's" are fired vertically "Straight Up" and at much higher muzzle velocities & G-Forces. TERRA MEGA INFERNO operations would be strictly Un-Manned & Non-Living Cargo & Consumable launches only, due to the extreme G-Forces generated at launch, and extreme cold temperatures of the payload section and its super cooled ice core. Also, due to the fact there is little highly explosive or flammable materials onboard the "RBSV's" as they are launched "fired" into orbit; on site, and down range safety would be enhanced compared to conventional chemical rocket systems presently in use. Reduction in launch costs is primary benefit here, and expediential increases in number of launch's.

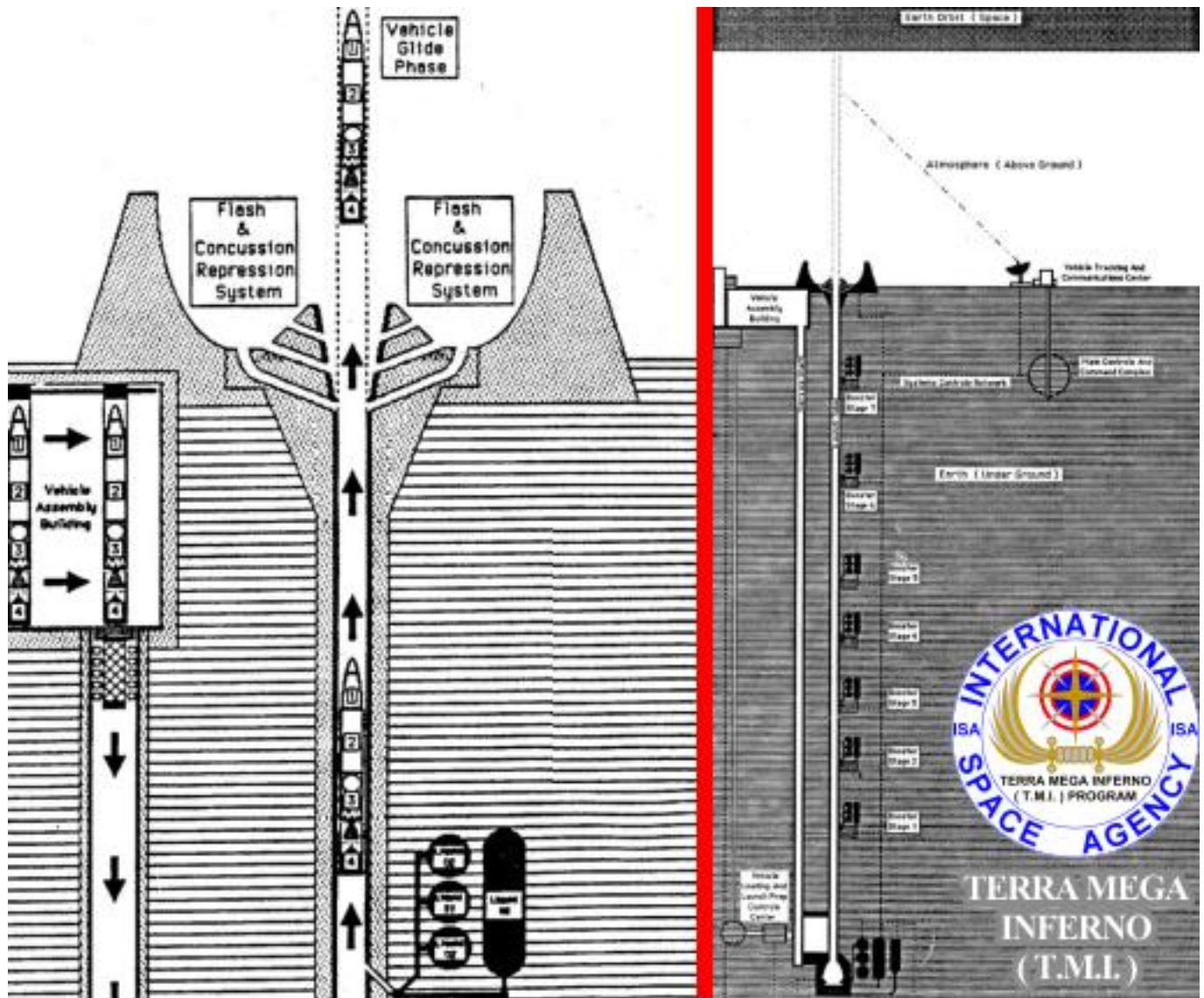

International Ground Based Vertical Tube Space Launch System (I.G.B.V.T.S.L.S.) -&- Program

G. General Information

<i>Project Title:</i>	<i>“TERRA MEGA INFERNO” (T.M.I.) - (I.G.B.V.T.S.L.S. -&- Program) International Ground Based Vertical Tube Space Launch System -&- Program</i>
<i>Brief Project Description:</i>	International Ground Based Vertical Tube Space Launch System, Using Multi Staged Gas Stream Vortex Injectors To Accelerate A Supersonic Gas Column Of, Super High Pressure Steam & Hot Gases Generated By Liquid Hydrogen Oxygen Combustion & Heat Conversion of Water to Steam, Up a Reinforced Concrete Launch Tube, To Propel a Single Stage Reusable Ballistic Space Vehicle “R.B.S.V.” At High G's Into Earths Orbit.
<i>Prepared By:</i>	Admiral, Rick R. Dobson, Jr. - United States - Chairman, CEO, Founder, International Space Agency, ISA
<i>Date:</i>	First Published on the 21 January 1988 – Republished on 1 May, 2017

H. Project Objectives:

PURPOSE: To Place Cargo and Consumables into Earths Orbit utilizing a Reinforced Concrete Vertical Tube of Substantial Length, Scale, and Robustness, which is lined with a seamless solid high heat resistant steal inner sheath that is machined and polished to a super fine super smooth surface, and uses a water vapor steam super heated gas column energized by a multi staged liquid hydrogen oxygen injector system, which propels a **Reusable Ballistic Space Vehicle "RBSV"** up and out of the vertical launch tube with a column of super heated supersonic column of expanding gas up the vertical tube at very high G-Forces to impart a major part of the acceleration forces needed to achieve orbital velocity, and stable orbital insertion of the Cargo and **"RBSV"**. The **"RBSV"** would have a small conventional propulsion section at its rear section that will guide and enhance the vehicles trajectory, course, heading, and orbital acceleration velocities as needed and required during its orbital accent and insertion phase. Core of the vehicle payload bay is filled with cargo and consumables immersed in water and then super cooled to create a solid ice core in the cargo bay of the **"RBSV"**. The items suspended in the super cooled ice core will with stand extremely high G-Forces at launch. The super cooled ice core is machined on its outer surface to exact specifications to be encased in a metal or composite outer shell "water tight payload bay". Once the **"RBSV"** and its super cooled cargo/payload is launched by TERRA MEGA INFERNO into Earths Orbit, the payload section of the **"RBSV"** is removed on orbit at a space station or processing facility, and the **"RBSV"** is then reconfigured for controlled reentry and parachute or parasail recovery. On orbit the payload section is also processed, by hooking cargo section and super cooled ice core, and the contents stored/suspended internally, up to a station cooling system to convert excess heat generated on the station through heat exchange tubing in the payload ice core, and convert the cold core into cooling the heat exchange. As the heat exchange in the transfer to the stations cooling system occurs, the ice core heats up as it bleeds off its cold stored energy, and converts the ice core to liquid water. When the block of ice core is totally converted to liquid water, the water is then pumped into water storage tanks on the Space Station, and the cargo and consumables are now removed from the drained cargo section. The liquid Water can now be used on orbit for drinking, washing, cleaning, and research, commercial, Industrial processes, as well as "cracked" by electrolysis from onboard power grid to convert the water into Hydrogen and Oxygen for use in the Stations Atmospheric Needs and also as Fuel for Orbital and Station Uses. The empty shell of the cargo section can now be used for construction or storage uses in orbit, or could be returned to Earth by ISA International Space Planes bringing cargo to the station, and leaving with the empty cargo shell in there cargo bays, to be returned, refurbished, and reused at the original launch site on Earth. This launch system will not create orbital space debris. As a closing statement here, it must be noted that "rail gun" electromagnetic repulsor technology could be imbedded into the walls of the vertical launch tube, to propel an **"RBSV"** up the vertical launch tube by electromagnetic means, instead of the use of expanding hot gases to achieve this rapid acceleration up, and out, of the vertical launch tube. Note: See International Space Plane (ISP) Program Proposal for further information on this assisted launch technology. **The International Ground Based Vertical Tube Space Launch System & Program, will be the primary system for inserting massive amounts of consumables, raw materials, and equipment into Earths Orbit, for the success of any Space Program of Scale & Scope.**

RESEARCH & CAPABILITY: Specific Areas of Mission & Operations & Management Authority:

- Underground Construction and Tunneling required for the Vertical Launch Tube and it supporting underground facilities, equipment, and systems. Mining and Underground Construction Companies and Expertise will be critical to this endeavor.
- Advanced PhD & Scientific Expertise in Armory Knowledge of Large Military Cannons and Metallurgy will be instrumental.
- Advanced PHD & Scientific Expertise in High Pressure High Velocity Gas Column and Flow Dynamics will be instrumental.
- Advanced PhD & Scientific Expertise in Specialized High Heat Reinforced Concrete Manufacturing will be instrumental.
- Advanced Expertise in metal bonding, welding, and surface grinding to precise tolerances and specifications will be instrumental.
- Advanced Aerospace & Space Vehicle Engineering & Manufacturing Expertise will be critical to this endeavor.
- Advanced PhD & Scientific Expertise in super cooled liquids and there reaction to environmental variables will be instrumental.

BENEFITS: Very High Volume Launch Capacity at very low launch cost per pound. Projectiles **"RBSV's"** are launched in the very same way as a shell in a modern military cannon is fired down range, except the **"RBSV's"** are fired vertically "Straight Up" and at much higher muzzle velocities & G-Forces. TERRA MEGA INFERNO operations would be strictly Un-Manned & Non-Living Cargo & Consumable launches only, due to the extreme G-Forces generated at launch, and extreme cold temperatures of the payload section and its super cooled ice core. Also, due to the fact there is little highly explosive or flammable materials onboard the **"RBSV's"** as they are launched "fired" into orbit; on site, and down range safety would be enhanced compared to conventional chemical rocket systems presently in use. Reduction in launch costs is the primary benefit here, as is expediential increases in number of launch's.

FUNDING: A Single or Combined Grant or Donation in the sum of \$7 Million U.S. Dollars is sought, to fund a "Start Up" Perpetual Research, Development, and Operations Program, to obtain/secure key Scientific, Engineering, Operational Personnel, Facilities, Equipment, and Materials required to build, organize, and operate a **"TERRA MEGA INFERNO" International Ground Based Vertical Tube Space Launch System, Launch Site, Recovery Operations, and Program Management.**

GROUND BASED SPACE LAUNCH SYSTEM (LTBPS) LAUNCH TUBE BALLISTIC PROJECTILE SYSTEM

TERRA MEGGA INFRERNO
EXCLUSIVE PROPERTY OF THE
INTERNATIONAL SPACE AGENCY

**TRADEMARK
COPYRIGHT
1989 TO 2015
ALL RIGHTS
RESERVED**

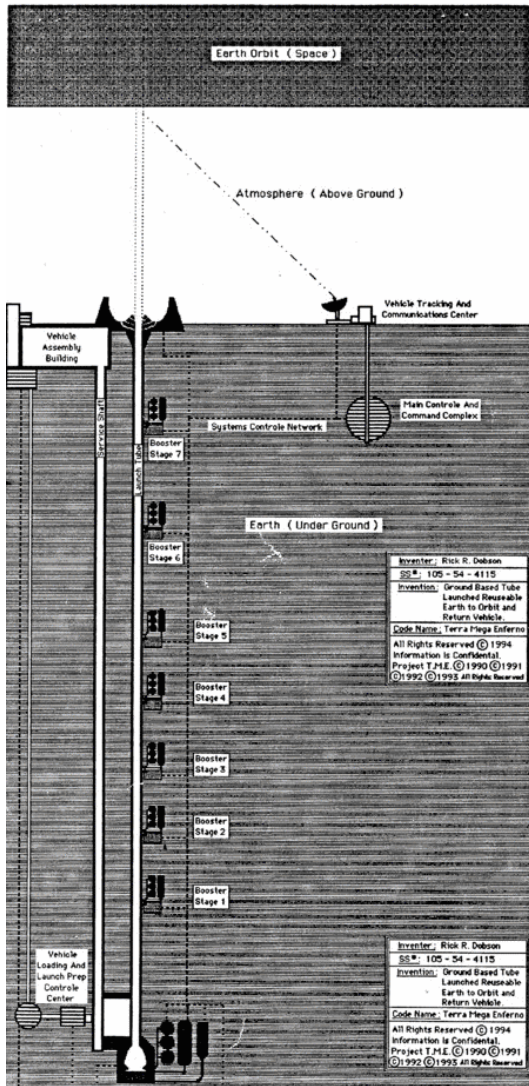

Fig. 1.E.1

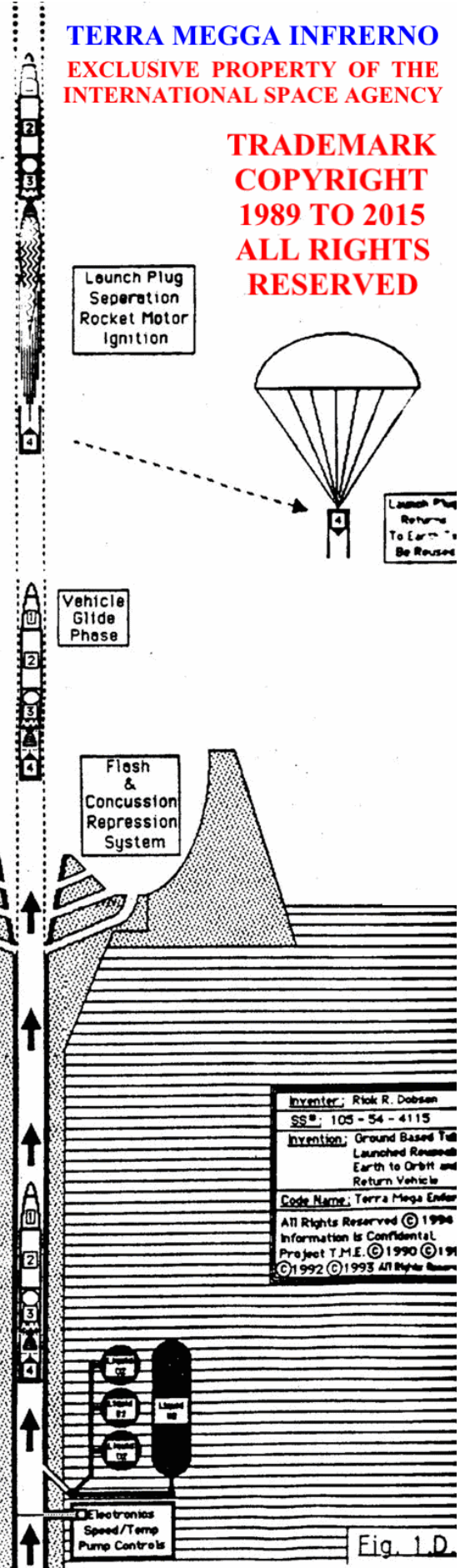
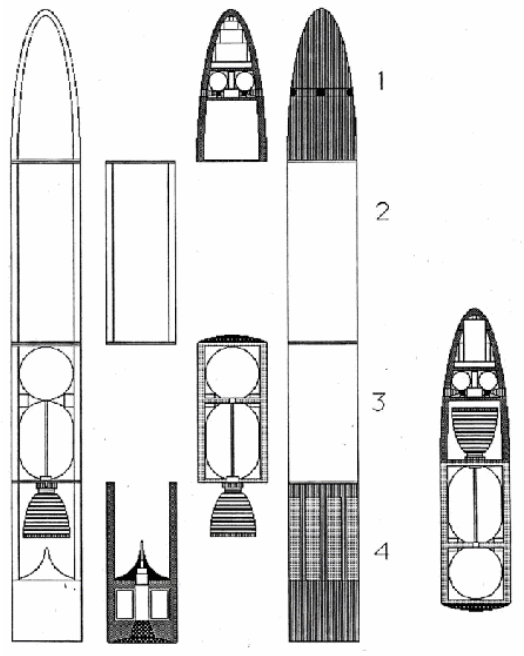
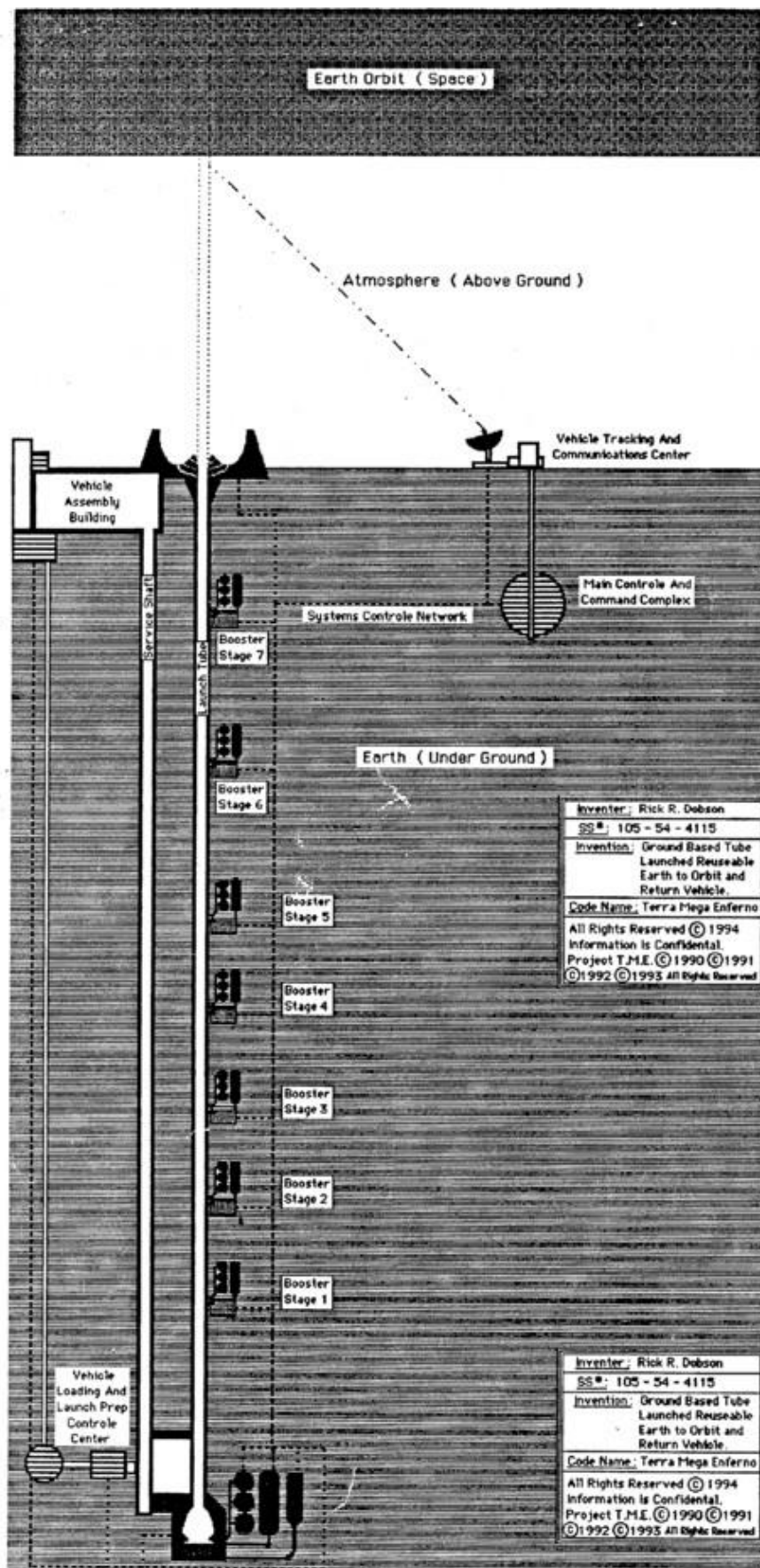

Fig. 1.D



TERRA MEGA INFERNO – SYSTEM OVERVIEW



SECTION 1 - LOADING SECTION & THRUST CHAMBER

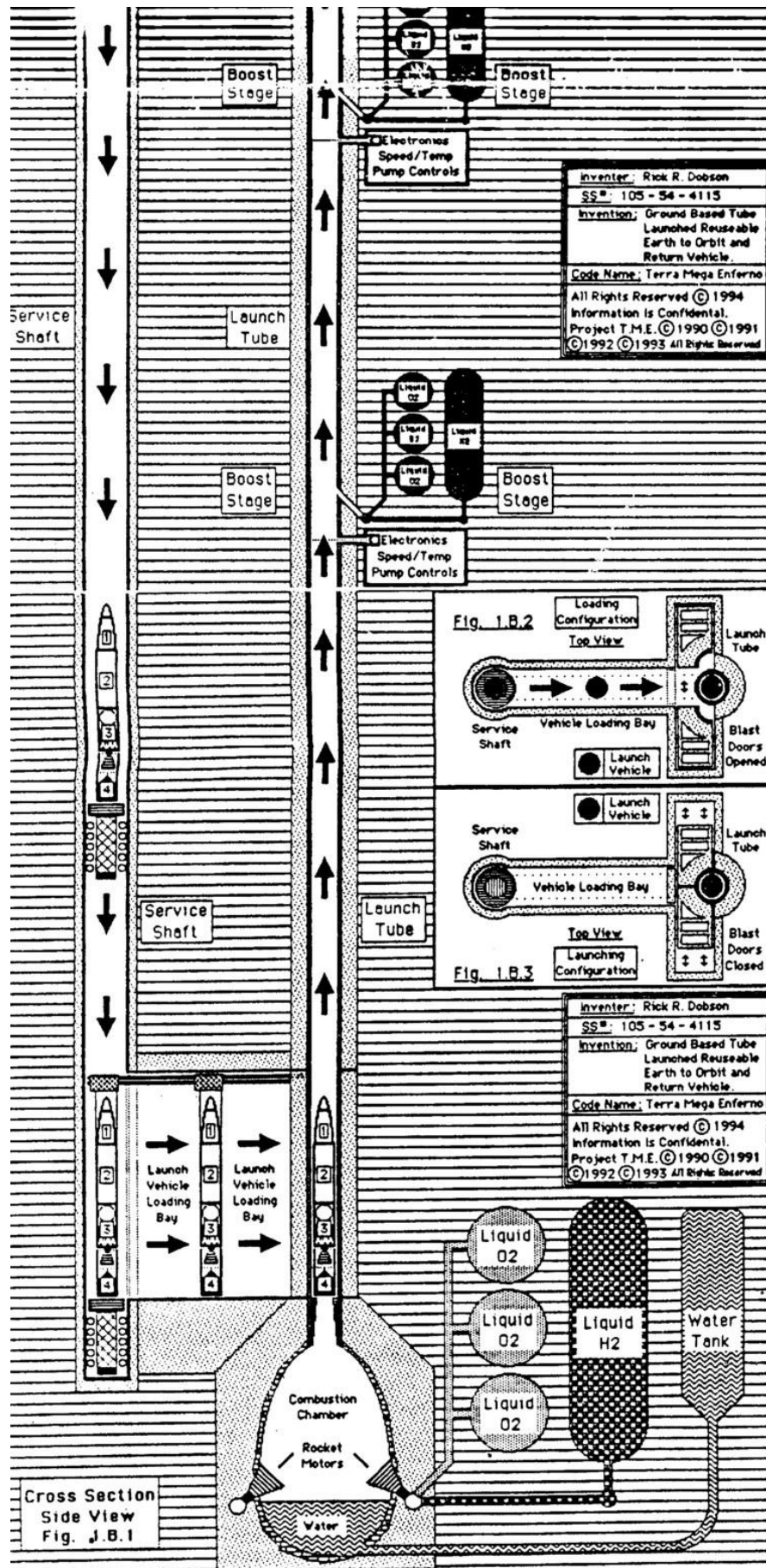

SECTION 2 – DECENT / LAUNCH TUBES & THRUST STAGING

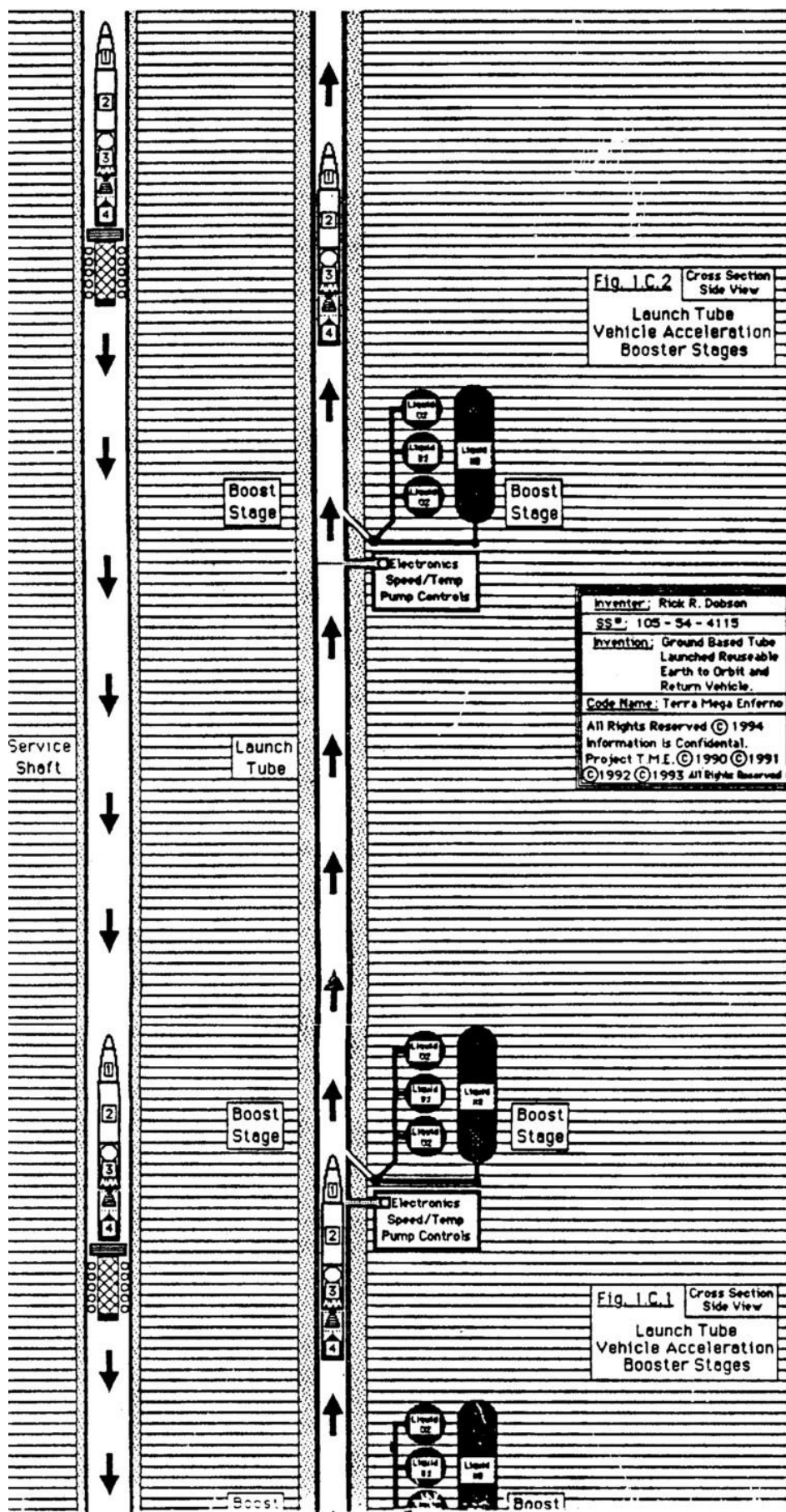

Inventor: Rick R. Dobson
 SS#: 105 - 54 - 4115
 Invention: Ground Based Tube Launched Reusable Earth to Orbit and Return Vehicle.
 Code Name: Terra Mega Enferno
 All Rights Reserved © 1994
 Information is Confidential.
 Project T.M.E. © 1990 © 1991
 © 1992 © 1993 All Rights Reserved

SECTION 3 – VEHICLE ASSEMBLY BAY & CONCUSSION SUPPRESSION SYSTEM

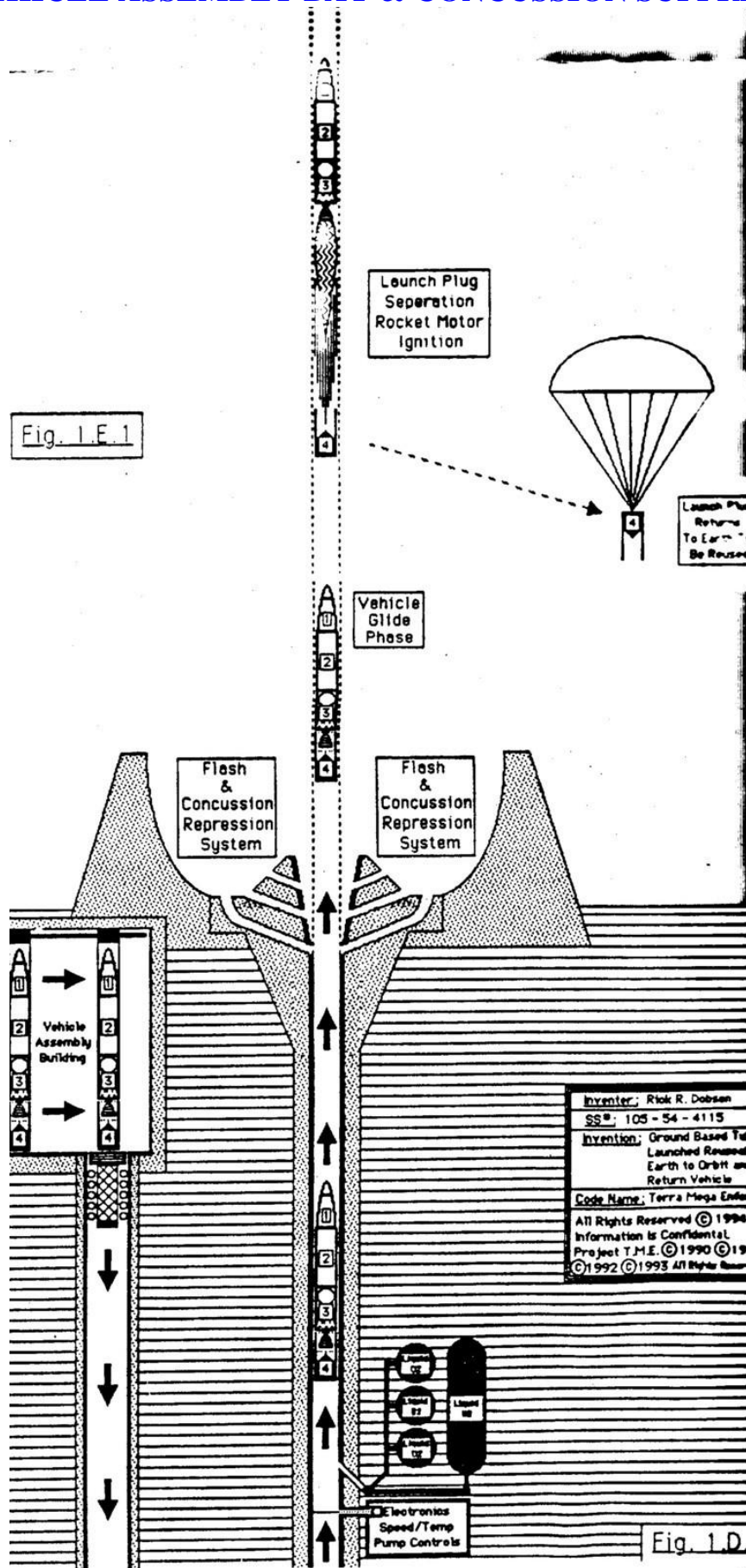

TUBE BOOST LAUNCH & VEHICLE INDEPENDENT ORBITAL ACCENT PHASE

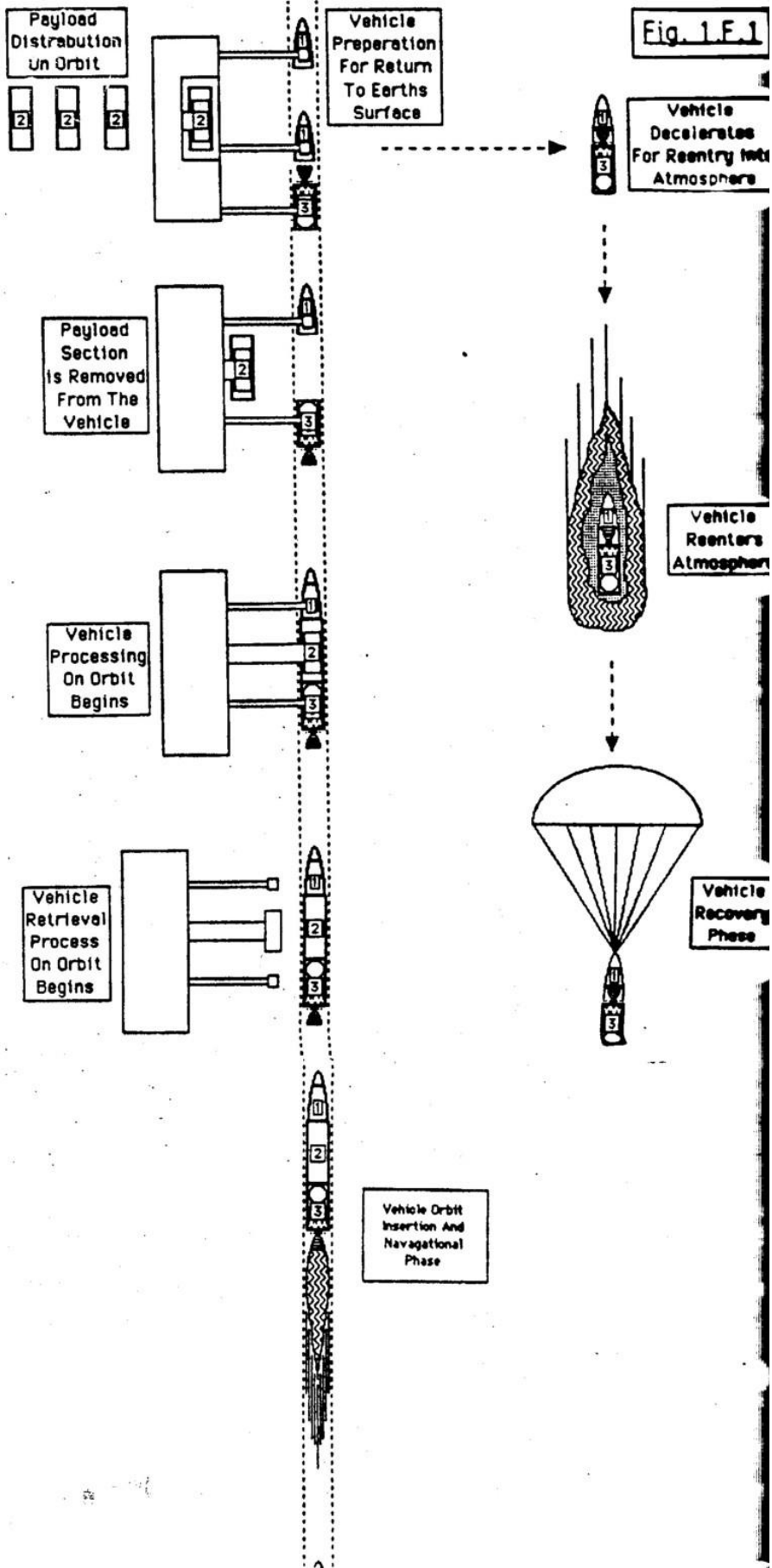

REUSABLE BALLISTIC SPACE VEHICLE – R.B.S.V.

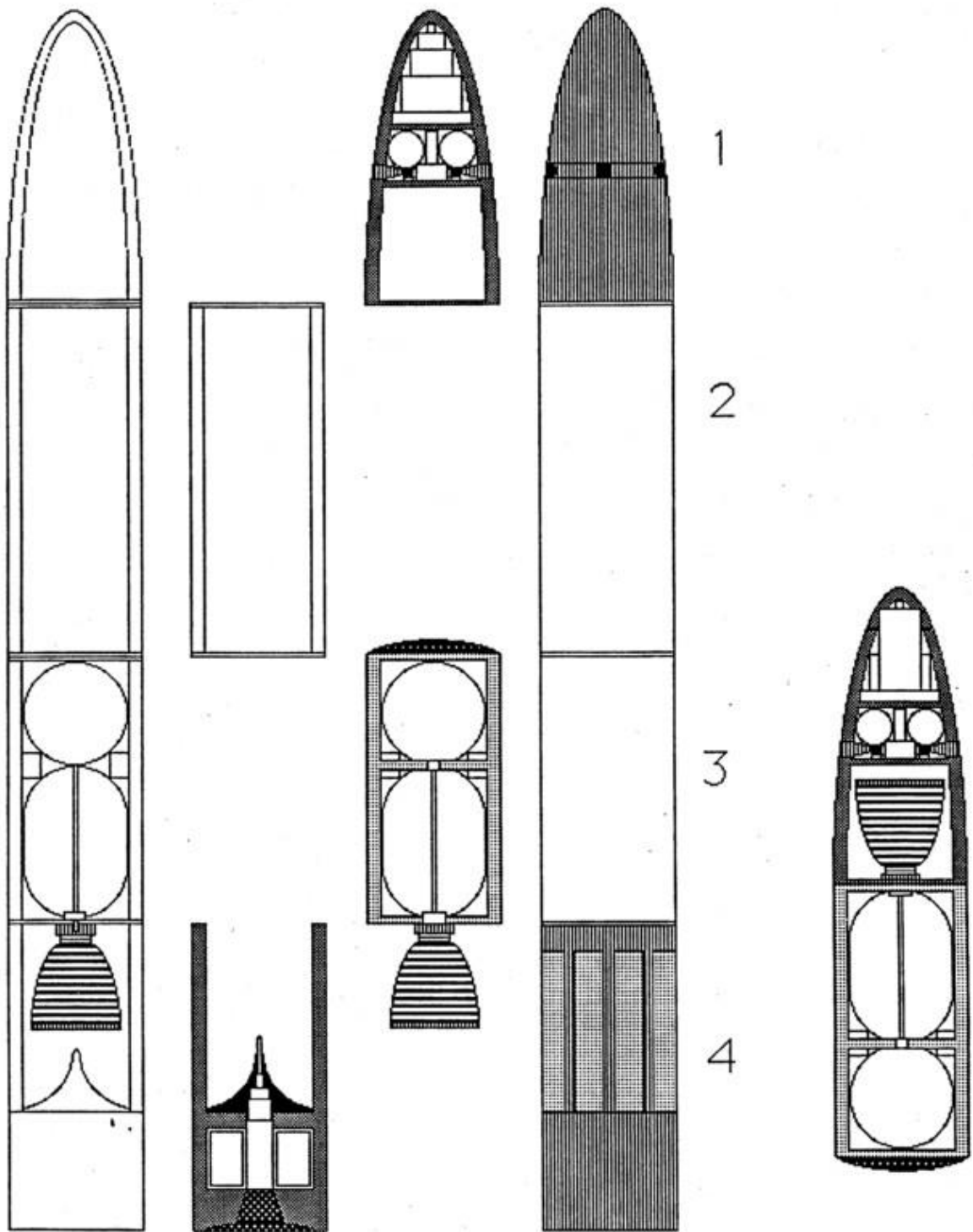

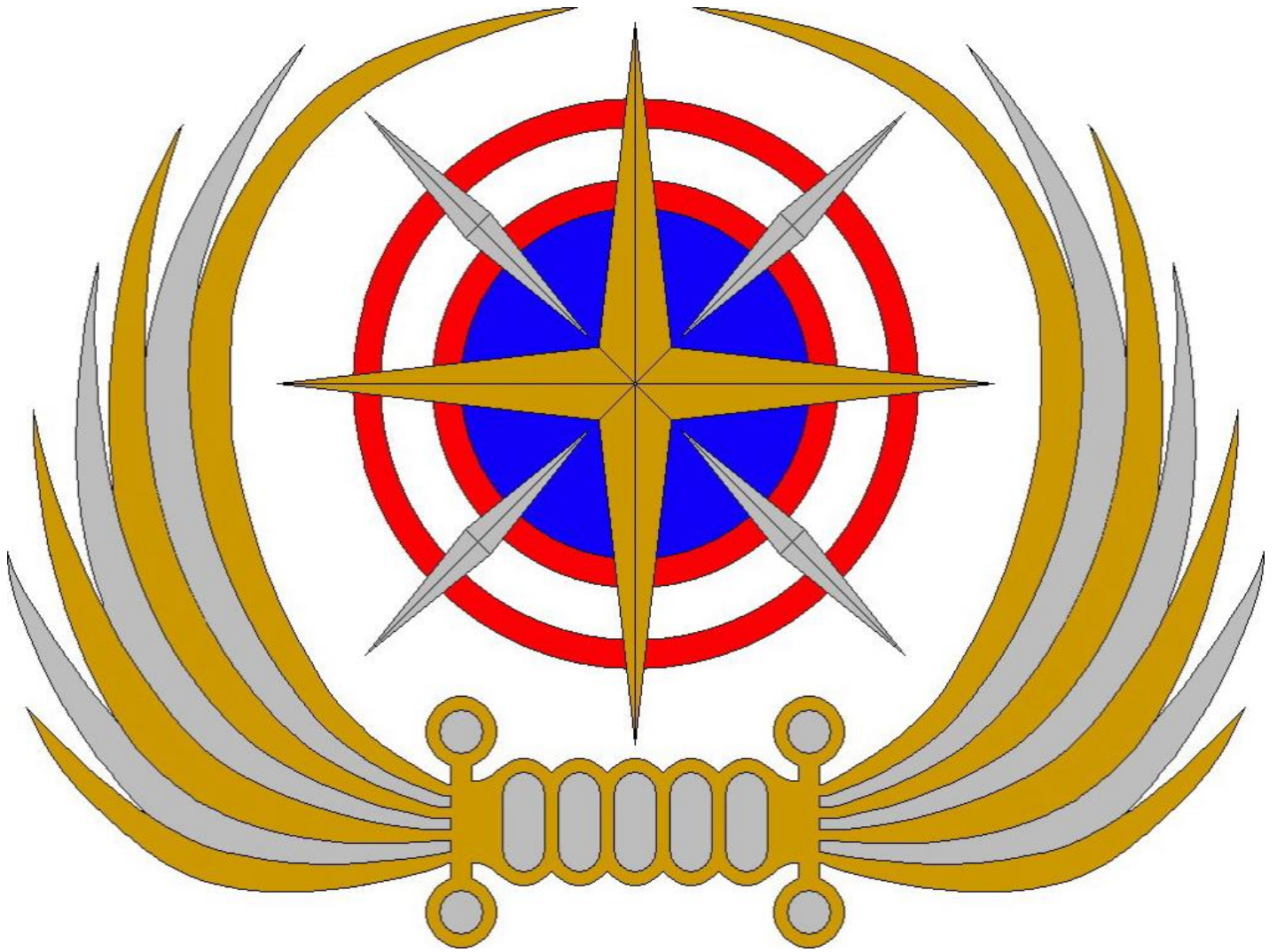

International Space Agency, ISA

International Space Administration

Founded In 1986 -&- Incorporated In 1990

Presently Seeking International Treaty -&- Charter Status

2017 - PROPOSAL

AIRCRAFT CONCEPTS, BY:

ADMIRAL, RICK R. DOBSON, JR.

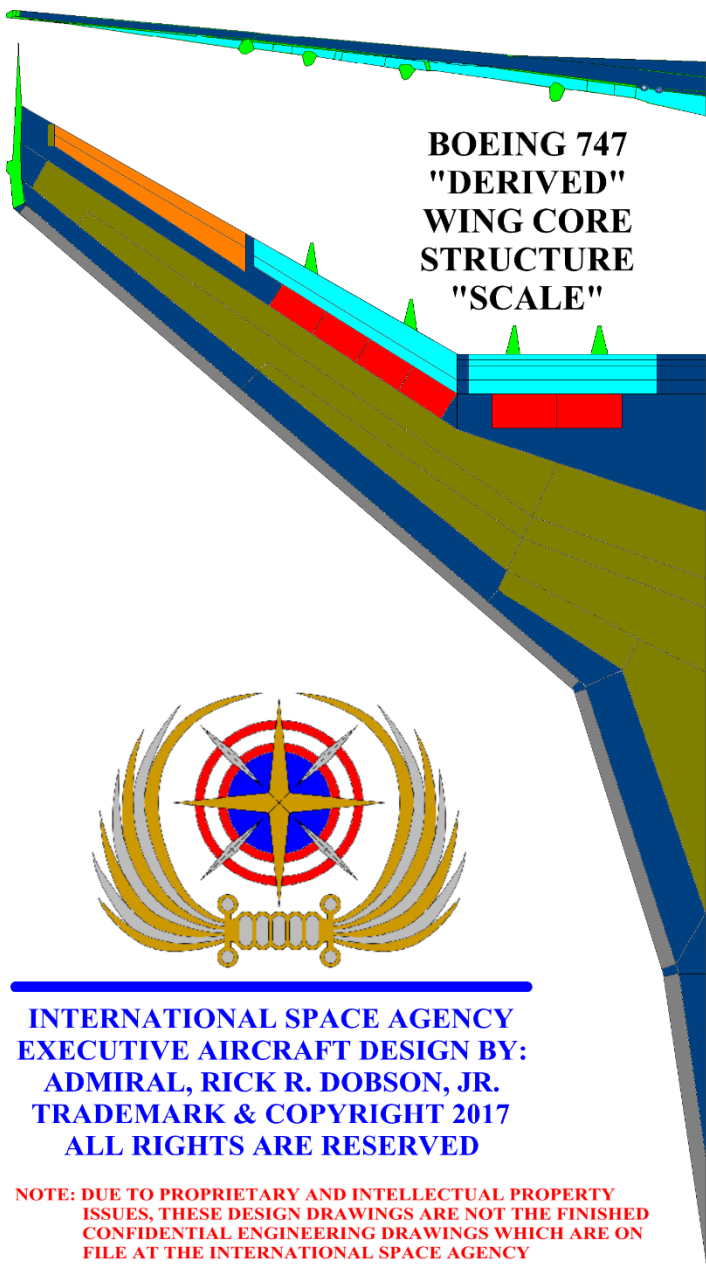

**BOEING 747
"DERIVED"
WING CORE
STRUCTURE
"SCALE"**

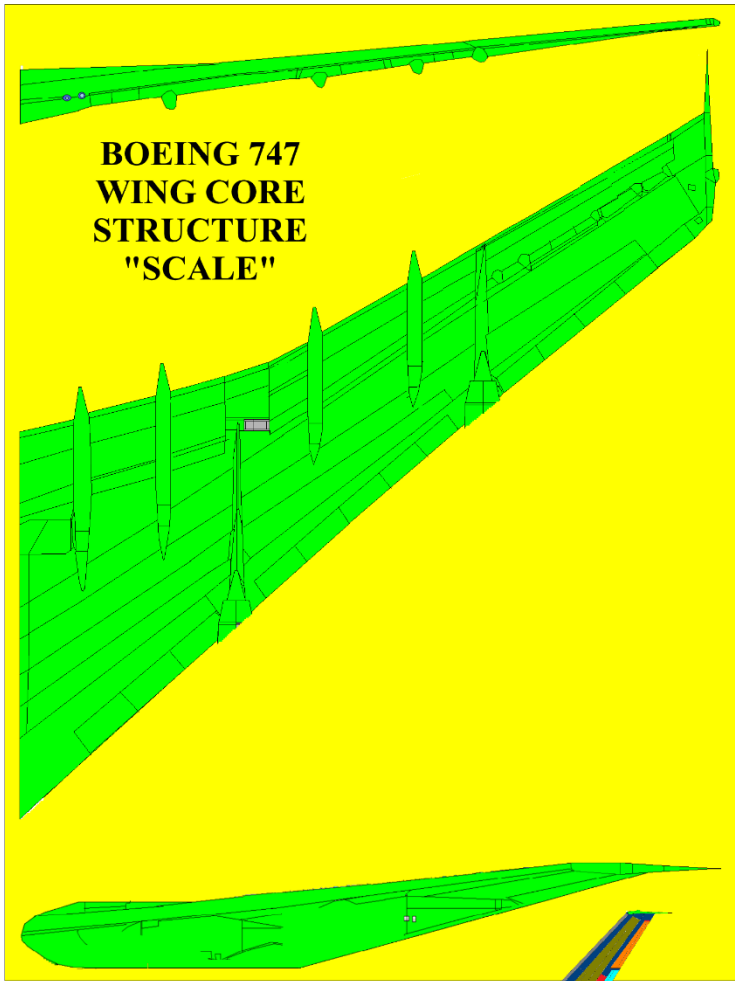

**BOEING 747
WING CORE
STRUCTURE
"SCALE"**



**INTERNATIONAL SPACE AGENCY
EXECUTIVE AIRCRAFT DESIGN BY:
ADMIRAL, RICK R. DOBSON, JR.
TRADEMARK & COPYRIGHT 2017
ALL RIGHTS ARE RESERVED**

**NOTE: DUE TO PROPRIETARY AND INTELLECTUAL PROPERTY
ISSUES, THESE DESIGN DRAWINGS ARE NOT THE FINISHED
CONFIDENTIAL ENGINEERING DRAWINGS WHICH ARE ON
FILE AT THE INTERNATIONAL SPACE AGENCY**

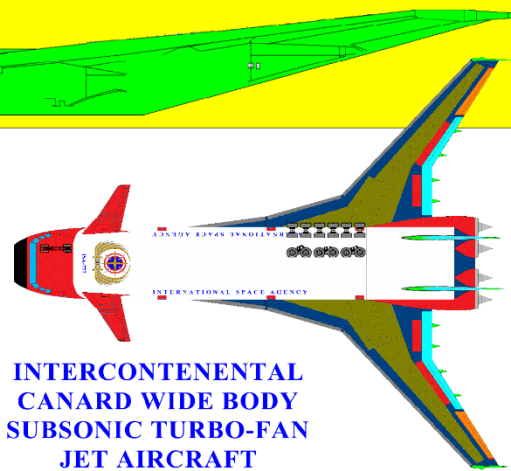

**INTERCONTINENTAL
CANARD WIDE BODY
SUBSONIC TURBO-FAN
JET AIRCRAFT**

DUCTED POD / TURBO-FAN / JET ENGINES

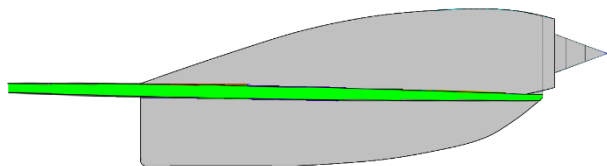

**NOTE: TURBO-FAN JET ENGINES
ARE FROM BOEING 787-800**

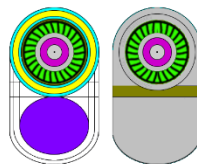
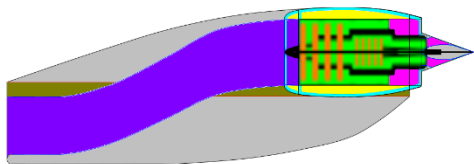
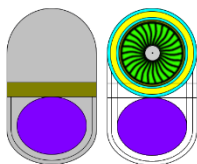
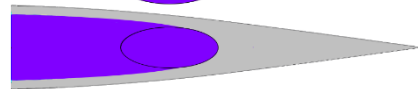
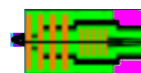
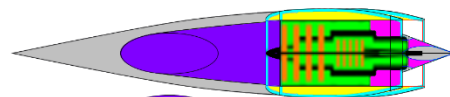
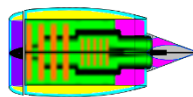

INTERCONTINENTAL CANARD WIDE BODY SUBSONIC TURBO-FAN JET AIRCRAFT



INTERNATIONAL SPACE AGENCY
 EXECUTIVE AIRCRAFT DESIGN BY:
 ADMIRAL, RICK R. DOBSON, JR.
 TRADEMARK & COPYRIGHT 2017
 ALL RIGHTS ARE RESERVED

NOTE: AIRCRAFT SIZE AND OPERATIONS REQUIREMENTS AND CAPABILITIES WOULD BE IN THE CLASS OF THE BOEING 747 OR 787-800 AIRCRAFT

NOTE: DUE TO PROPRIETARY AND INTELLECTUAL PROPERTY ISSUES, THESE DESIGN DRAWINGS ARE NOT THE FINISHED CONFIDENTIAL ENGINEERING DRAWINGS WHICH ARE ON FILE AT THE INTERNATIONAL SPACE AGENCY SPECIAL MENTION TO WRIGHT BROTHERS & BURT RUTAN WHO PIONEERED THE USE OF THE CANARD CONFIGURATION OF AERODYNAMIC CONTROL

NOTE: THE PROPOSED CONTRACTORS FOR THIS PROJECT WOULD BE: BOEING - U.S.A. -OR- AIRBUS - EUROPE

NOTE: WIDE BODY DESIGN IS TO ENHANCE OVERALL LIFT COEFFICIENT. ALSO THE WIDE BODY CONFIGURATION INCREASES THE OVER ALL EFFICIENT USE OF INTERNAL SPACE OF THE FUSELAGE

NOTE: PIVOTING NOSE SECTION CAN BE EMPLOYED FOR CARGO VERSION OF THIS AIRCRAFT

NOTE: WING CORE CONFIGURATION IS FROM BOEING 747

NOTE: LANDING GEAR SYSTEM IS FROM BOEING 787-800

NOTE: THE 4 TURBO-FAN JET ENGINE INTAKES ARE SHOWN WITH INTAKES ON THE BELLY OF THE AIRCRAFT, BUT IF DESIGN ISSUES ARISE, THE INTAKES CAN BE RECONFIGURED FOR PLACEMENT ON THE TOP OF THE AIRCRAFT

NOTE: VERTICAL TAIL CONFIGURATION IS SHOWN AS DUAL SYSTEM, BUT A SINGLE VERTICAL TAIL CONFIGURATION CAN BE EMPLOYED WITH LITTLE DESIGN ISSUES OR AIRFRAME STRUCTURE CHANGES

NOTE: VERTICAL TAIL CORE IS FROM BOEING 787-800

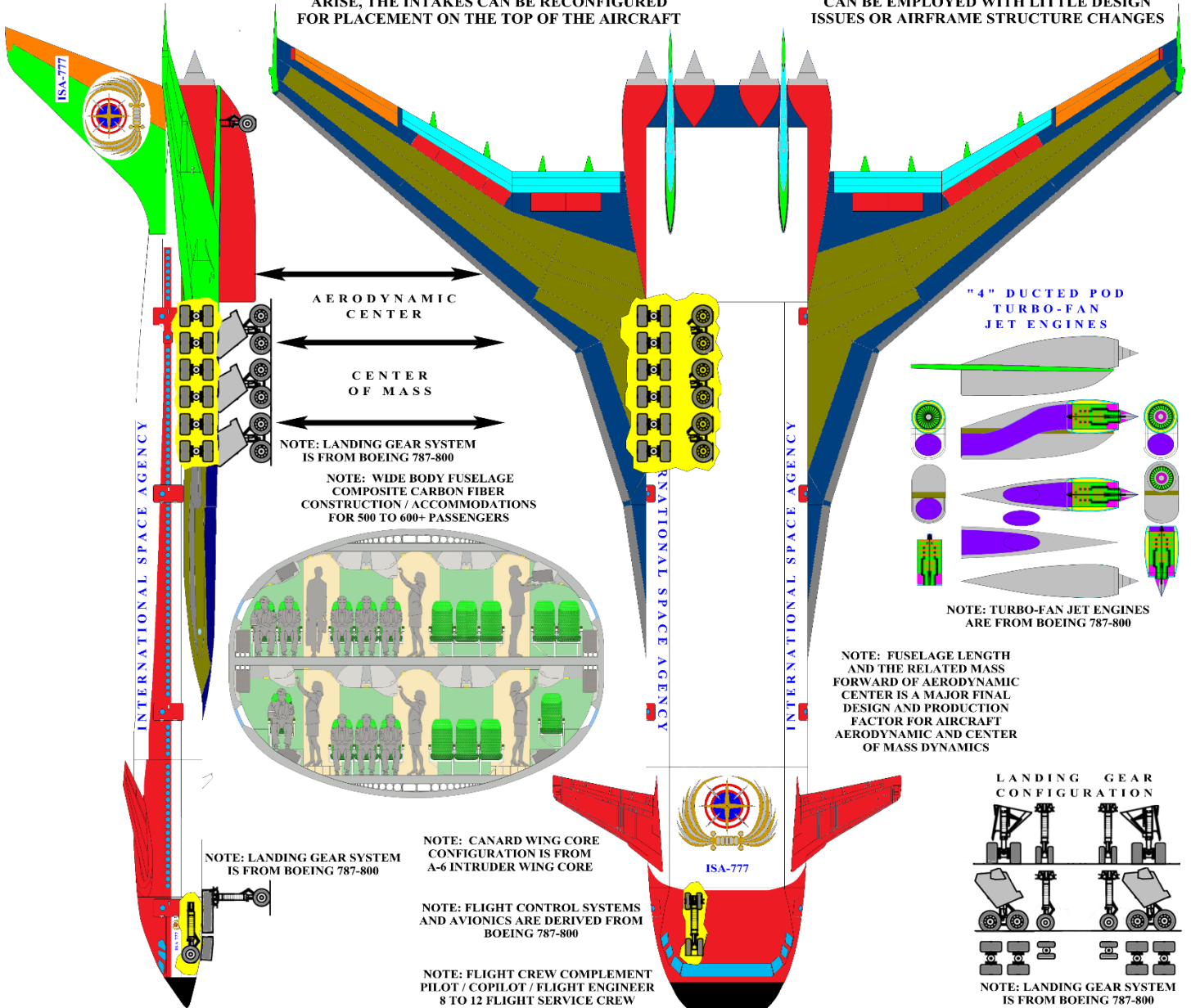

AERODYNAMIC CENTER

CENTER OF MASS

NOTE: LANDING GEAR SYSTEM IS FROM BOEING 787-800

NOTE: WIDE BODY FUSELAGE COMPOSITE CARBON FIBER CONSTRUCTION / ACCOMMODATIONS FOR 500 TO 600+ PASSENGERS

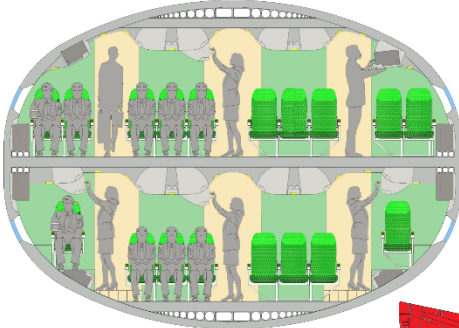

"4" DUCTED POD TURBO-FAN JET ENGINES

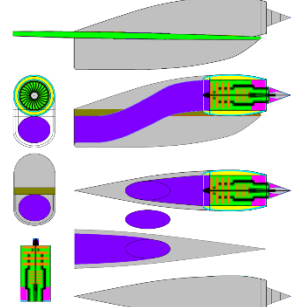

NOTE: TURBO-FAN JET ENGINES ARE FROM BOEING 787-800

NOTE: FUSELAGE LENGTH AND THE RELATED MASS FORWARD OF AERODYNAMIC CENTER IS A MAJOR FINAL DESIGN AND PRODUCTION FACTOR FOR AIRCRAFT AERODYNAMIC AND CENTER OF MASS DYNAMICS

NOTE: LANDING GEAR SYSTEM IS FROM BOEING 787-800

NOTE: CANARD WING CORE CONFIGURATION IS FROM A-6 INTRUDER WING CORE

NOTE: FLIGHT CONTROL SYSTEMS AND AVIONICS ARE DERIVED FROM BOEING 787-800

NOTE: FLIGHT CREW COMPLEMENT PILOT / COPILOT / FLIGHT ENGINEER 8 TO 12 FLIGHT SERVICE CREW

LANDING GEAR CONFIGURATION

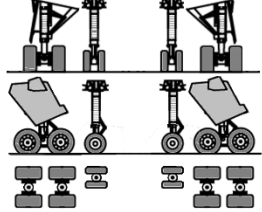

NOTE: LANDING GEAR SYSTEM IS FROM BOEING 787-800

**International Strato-Cruiser
"Supersonic/Hypersonic"
Wide Body Aircraft**



**International Space Agency - I.S.A.
International Space Administration**

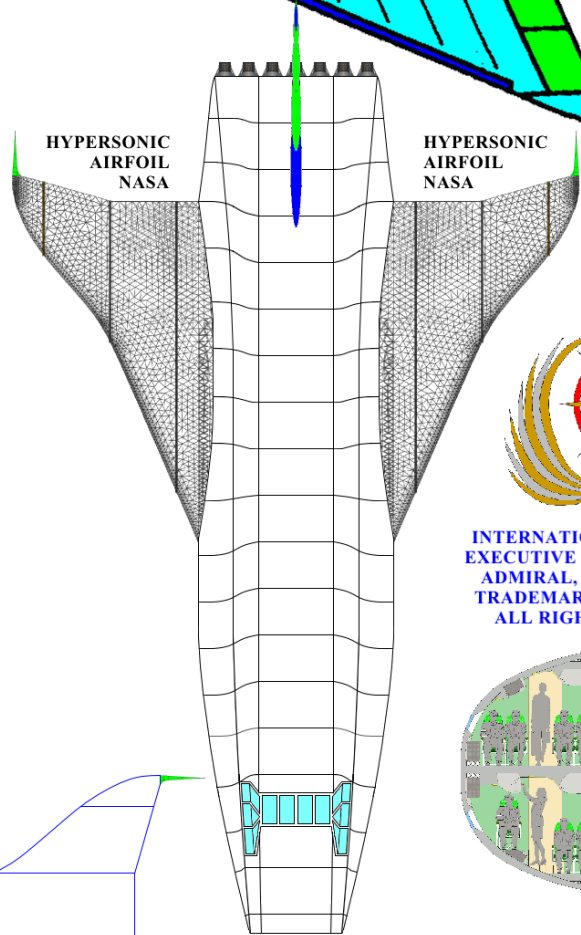
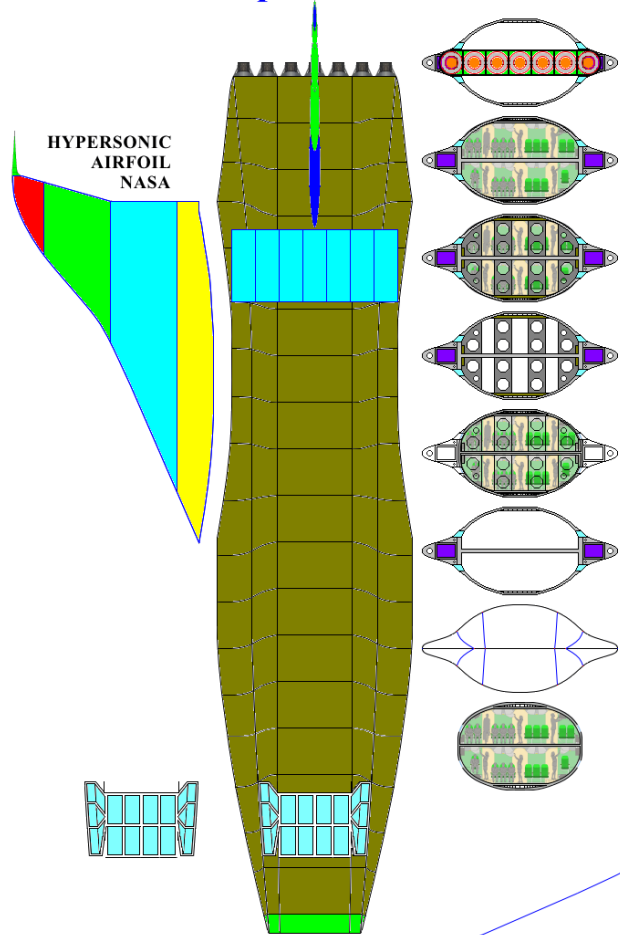
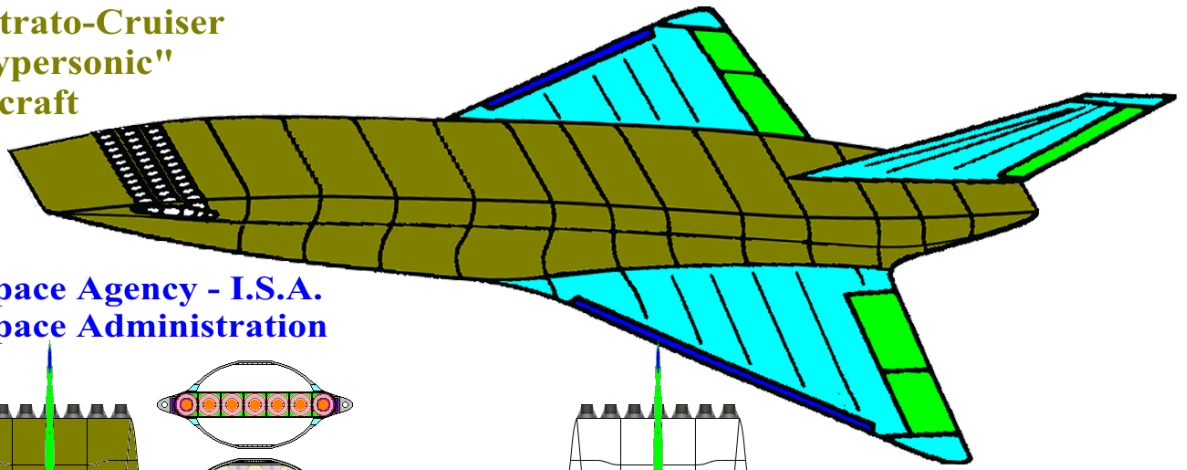

**INTERNATIONAL SPACE AGENCY
EXECUTIVE AIRCRAFT DESIGN BY:
ADMIRAL, RICK R. DOBSON, JR.
TRADEMARK & COPYRIGHT 2017
ALL RIGHTS ARE RESERVED**

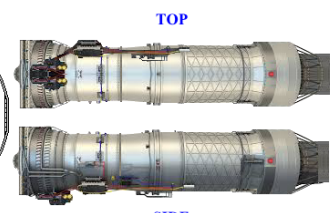
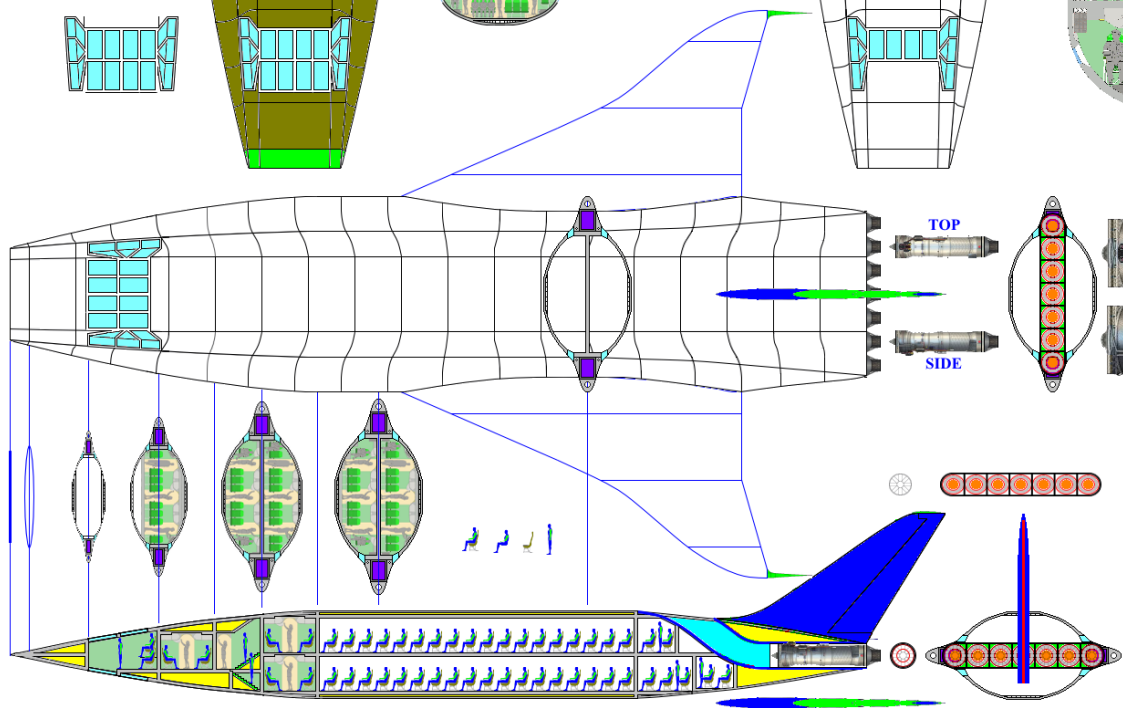
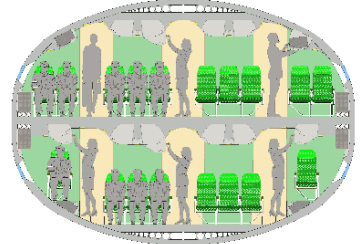

**CONCORD (FRANCE)
"TO SCALE" AFTERBURNING
TURBOFAN JET ENGINES**

**NOTE: DUE TO PROPRIETARY AND INTELLECTUAL PROPERTY ISSUES, THESE
DESIGN DRAWINGS ARE NOT THE FINISHED CONFIDENTIAL ENGINEERING
DRAWINGS WHICH ARE ON FILE AT THE INTERNATIONAL SPACE AGENCY**

INTERCONTENENTAL CANARD WIDE BODY SUPERSONIC/HYPERSONIC AFTERBURNING TURBO-FAN JET AIRCRAFT



INTERNATIONAL SPACE AGENCY
EXECUTIVE AIRCRAFT DESIGN BY:
ADMIRAL, RICK R. DOBSON, JR.
TRADEMARK & COPYRIGHT 2017
ALL RIGHTS ARE RESERVED

NOTE: DUE TO PROPRIETARY AND INTELLECTUAL PROPERTY ISSUES, THESE DESIGN DRAWINGS ARE NOT THE FINISHED CONFIDENTIAL ENGINEERING DRAWINGS WHICH ARE ON FILE AT THE INTERNATIONAL SPACE AGENCY SPECIAL MENTION TO WRIGHT BROTHERS & BURT RUTAN WHO PIONEERED THE USE OF THE CANARD CONFIGURATION OF AERODYNAMIC CONTROL

NOTE: THE PROPOSED CONTRACTORS FOR THIS PROJECT WOULD BE: BOEING - U.S.A. -OR- AIRBUS - EUROPE

NOTE: AIRCRAFT SIZE AND OPERATIONS REQUIREMENTS AND CAPABILITIES WOULD BE IN THE CLASS OF THE BOEING 747 OR 787-800 AIRCRAFT

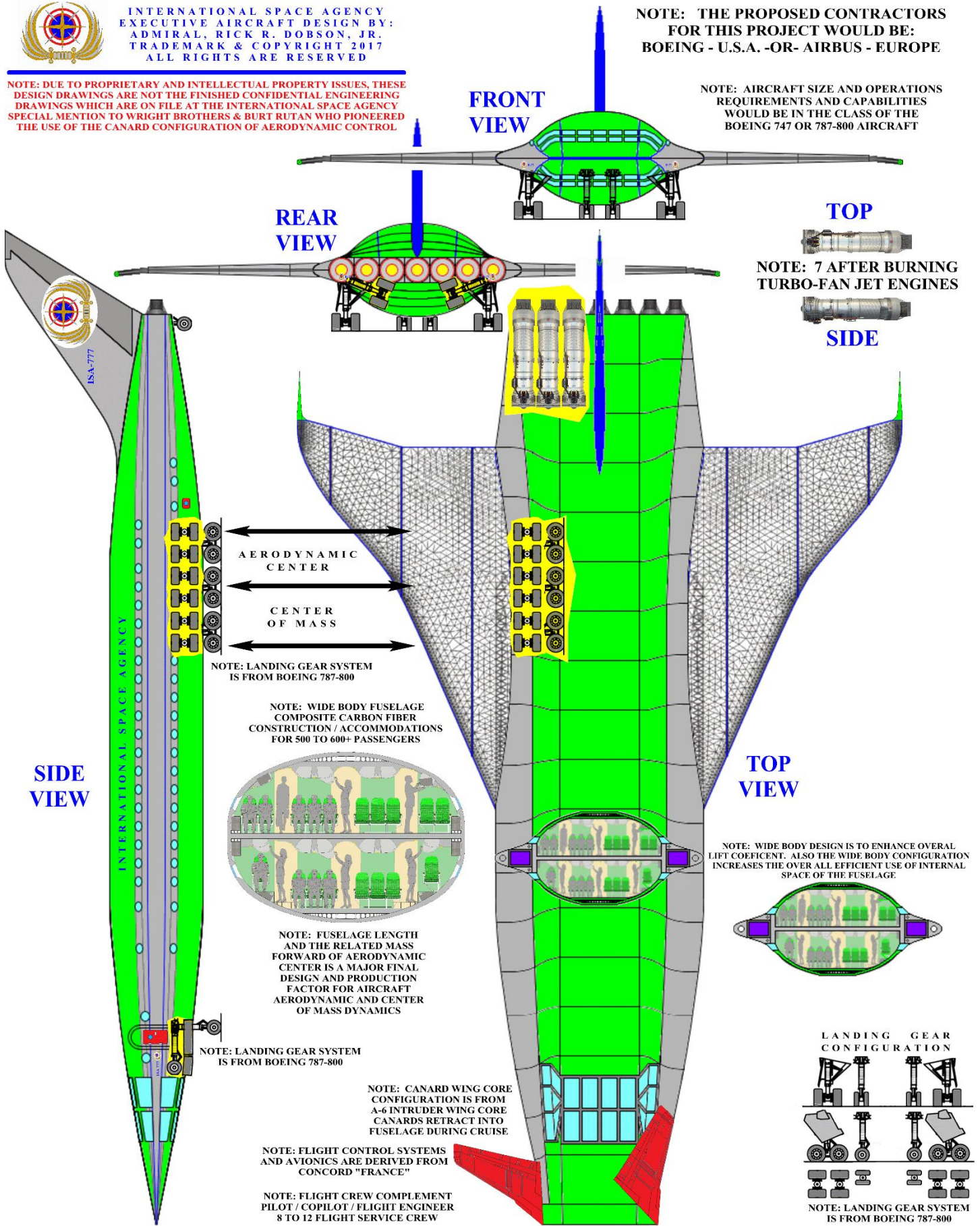

FRONT VIEW

REAR VIEW

TOP

NOTE: 7 AFTER BURNING TURBO-FAN JET ENGINES

SIDE

SIDE VIEW

TOP VIEW

AERODYNAMIC CENTER
CENTER OF MASS
NOTE: LANDING GEAR SYSTEM IS FROM BOEING 787-800

NOTE: WIDE BODY FUSELAGE COMPOSITE CARBON FIBER CONSTRUCTION / ACCOMMODATIONS FOR 500 TO 600+ PASSENGERS

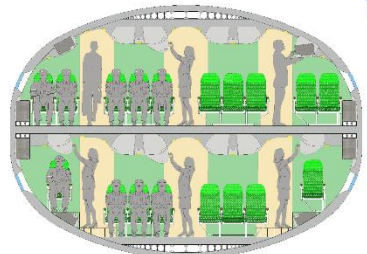

NOTE: FUSELAGE LENGTH AND THE RELATED MASS FORWARD OF AERODYNAMIC CENTER IS A MAJOR FINAL DESIGN AND PRODUCTION FACTOR FOR AIRCRAFT AERODYNAMIC AND CENTER OF MASS DYNAMICS

NOTE: LANDING GEAR SYSTEM IS FROM BOEING 787-800

NOTE: CANARD WING CORE CONFIGURATION IS FROM A-6 INTRUDER WING CORE CANARDS RETRACT INTO FUSELAGE DURING CRUISE

NOTE: FLIGHT CONTROL SYSTEMS AND AVIONICS ARE DERIVED FROM CONCORD "FRANCE"

NOTE: FLIGHT CREW COMPLEMENT PILOT / COPILOT / FLIGHT ENGINEER 8 TO 12 FLIGHT SERVICE CREW

NOTE: WIDE BODY DESIGN IS TO ENHANCE OVERALL LIFT COEFFICIENT. ALSO THE WIDE BODY CONFIGURATION INCREASES THE OVER ALL EFFICIENT USE OF INTERNAL SPACE OF THE FUSELAGE

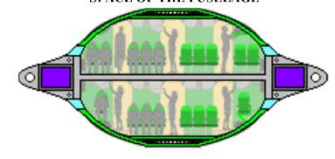

LANDING GEAR CONFIGURATION

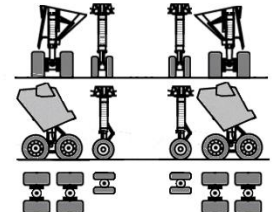

NOTE: LANDING GEAR SYSTEM IS FROM BOEING 787-800

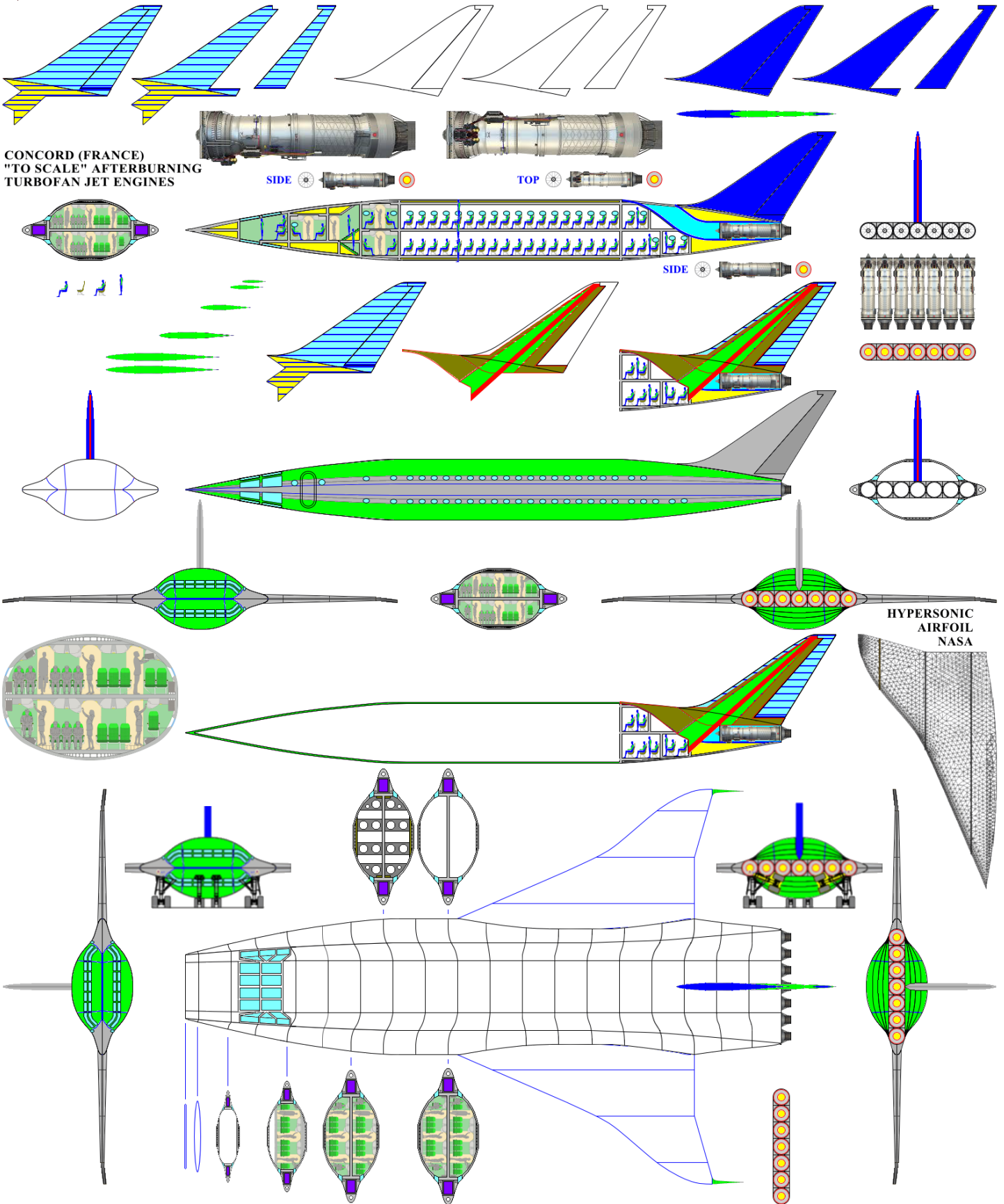

CONCORD (FRANCE)
 "TO SCALE" AFTERBURNING
 TURBOFAN JET ENGINES

HYPERSONIC
 AIRFOIL
 NASA

INTERNATIONAL SPACE AGENCY
 EXECUTIVE AIRCRAFT DESIGN BY:
 ADMIRAL, RICK R. DOBSON, JR.
 TRADEMARK & COPYRIGHT 2017
 ALL RIGHTS ARE RESERVED

NOTE: DUE TO PROPRIETARY AND INTELLECTUAL PROPERTY ISSUES, THESE
 DESIGN DRAWINGS ARE NOT THE FINISHED CONFIDENTIAL ENGINEERING
 DRAWINGS WHICH ARE ON FILE AT THE INTERNATIONAL SPACE AGENCY

**International Space Agency - I.S.A. / International Space Administration
International Strato-Cruiser "Supersonic/Hypersonic" Wide Body Aircraft**

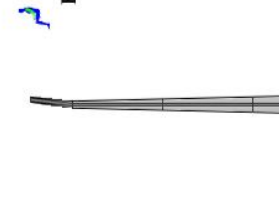
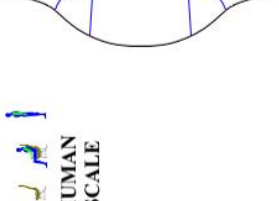
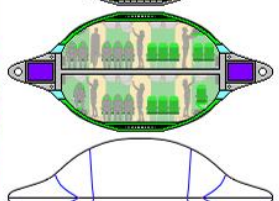
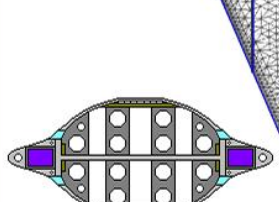
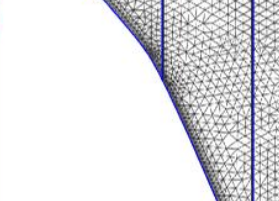
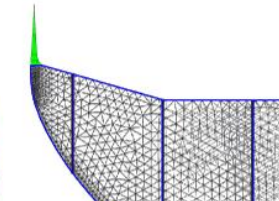
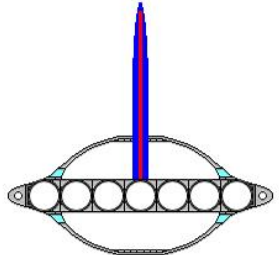
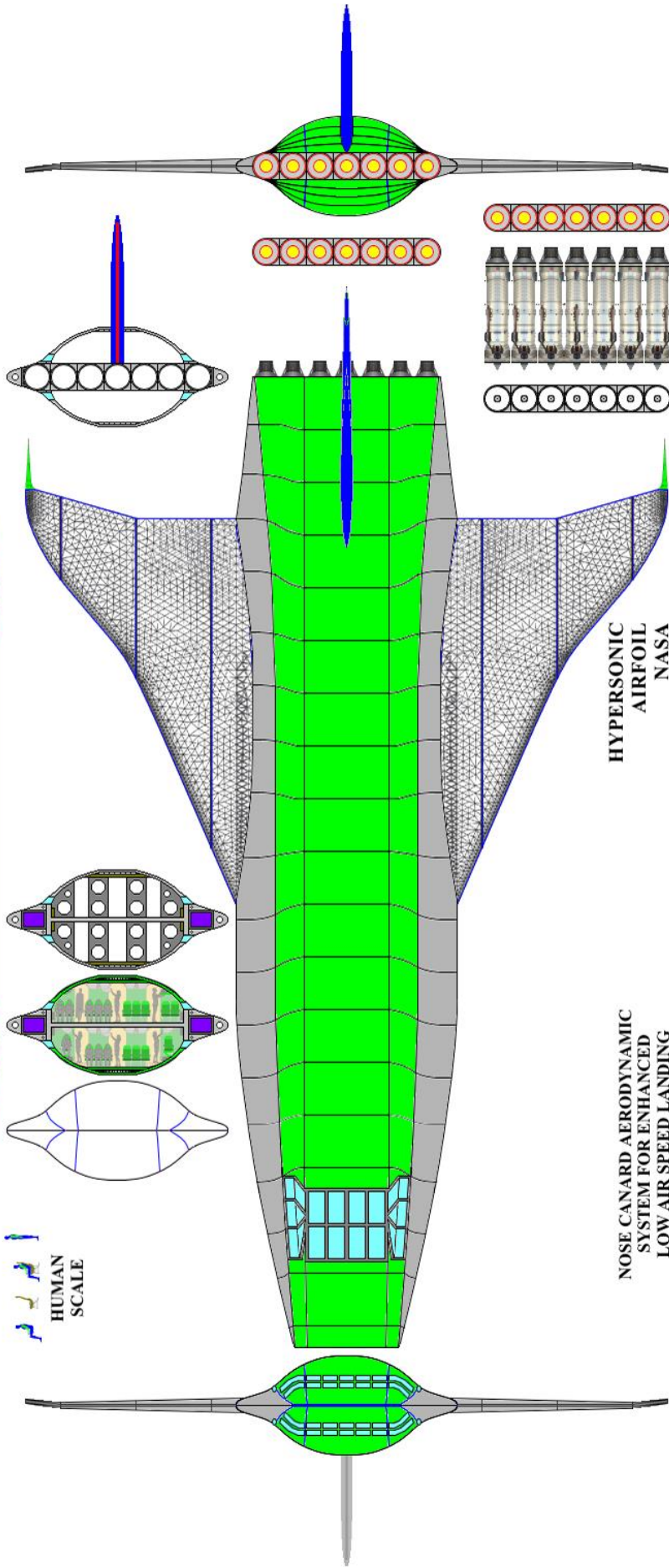
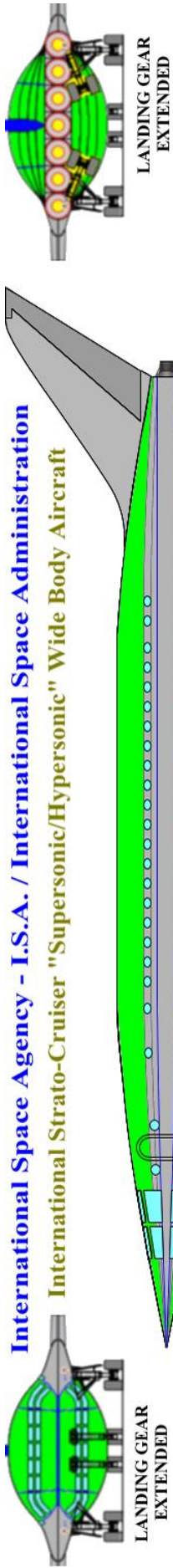

HUMAN SCALE

HYPERSONIC AIRFOIL
NASA

NOSE CANARD AERODYNAMIC SYSTEM FOR ENHANCED LOW AIR SPEED LANDING CHARACTERISTICS

NOTE: LANDING GEAR SYSTEM IS FROM BOEING 787-800

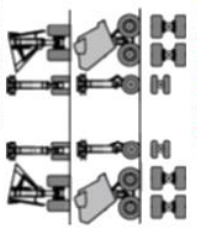

NOSE CANARD EXTENDED

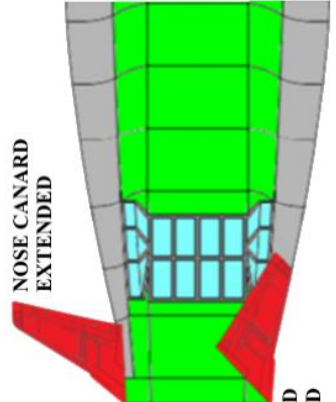

NOSE CANARD RETRACTED

(SEVEN "7") CONCORD (FRANCE) "TO SCALE" AFTERBURNING TURBOFAN JET ENGINES

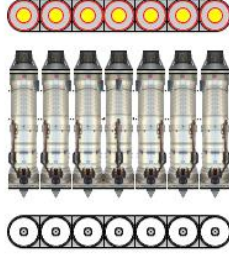

INTERNATIONAL SPACE AGENCY
EXECUTIVE AIRCRAFT DESIGN BY:
ADMIRAL, RICK R. DOBSON, JR.
TRADEMARK & COPYRIGHT 2017
ALL RIGHTS ARE RESERVED

NOTE: DUE TO PROPRIETARY AND INTELLECTUAL PROPERTY ISSUES, THESE DESIGN DRAWINGS ARE NOT THE FINISHED CONFIDENTIAL ENGINEERING DRAWINGS WHICH ARE ON FILE AT THE INTERNATIONAL SPACE AGENCY

International Space Agency - I.S.A. / International Space Administration
VERY SHORT TAKE OFF -&- LANDING
HIGH LIFT FUSELAGE / TURBO FAN
SUBSONIC JET AIRCRAFT

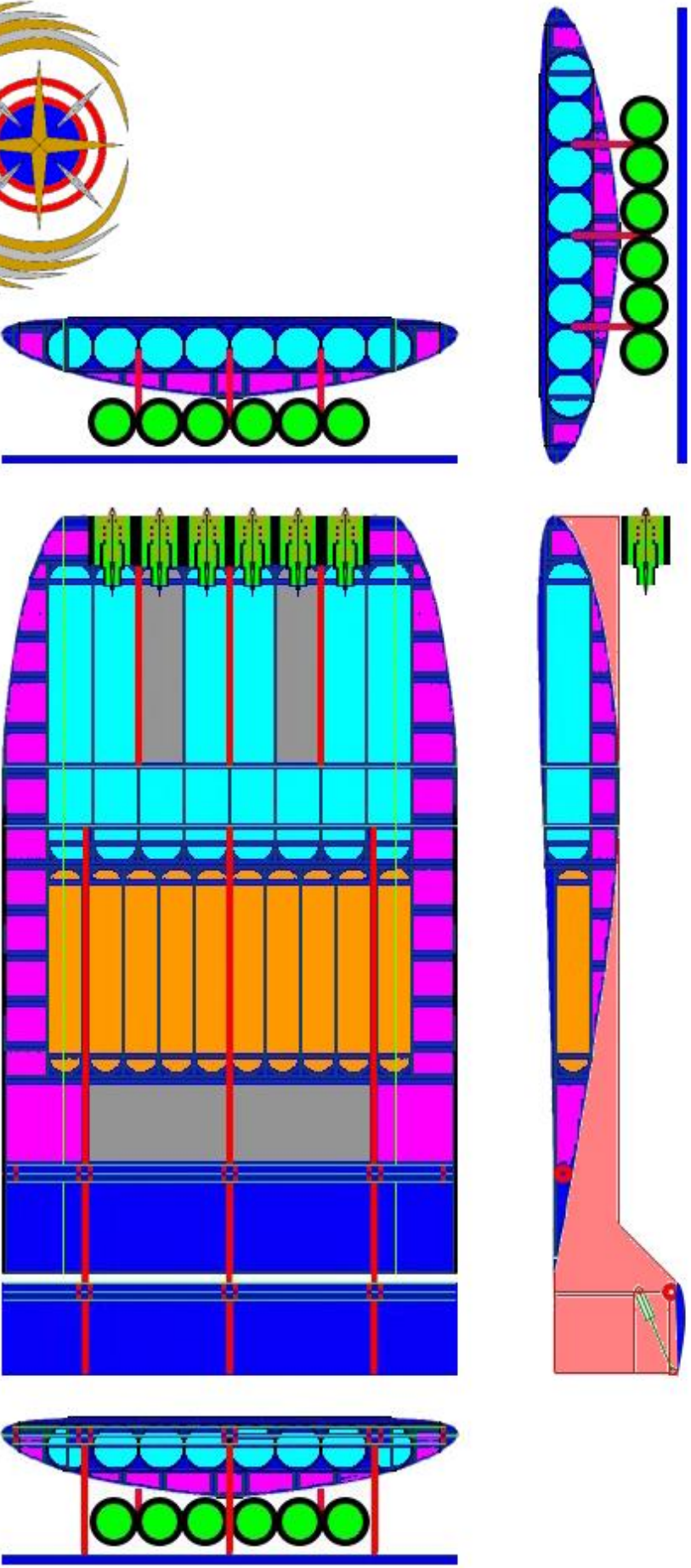

INTERNATIONAL SPACE AGENCY
EXECUTIVE AIRCRAFT DESIGN BY:
ADMIRAL, RICK R. DOBSON, JR.
TRADEMARK & COPYRIGHT 2017
ALL RIGHTS ARE RESERVED

NOTE: DUE TO PROPRIETARY AND INTELLECTUAL PROPERTY ISSUES, THESE
DESIGN DRAWINGS ARE NOT THE FINISHED CONFIDENTIAL ENGINEERING
DRAWINGS WHICH ARE ON FILE AT THE INTERNATIONAL SPACE AGENCY

International Space Agency - I.S.A. / International Space Administration
VERY SHORT TAKE OFF -&- LANDING
HIGH LIFT FUSELAGE / TURBO FAN
SUBSONIC JET AIRCRAFT

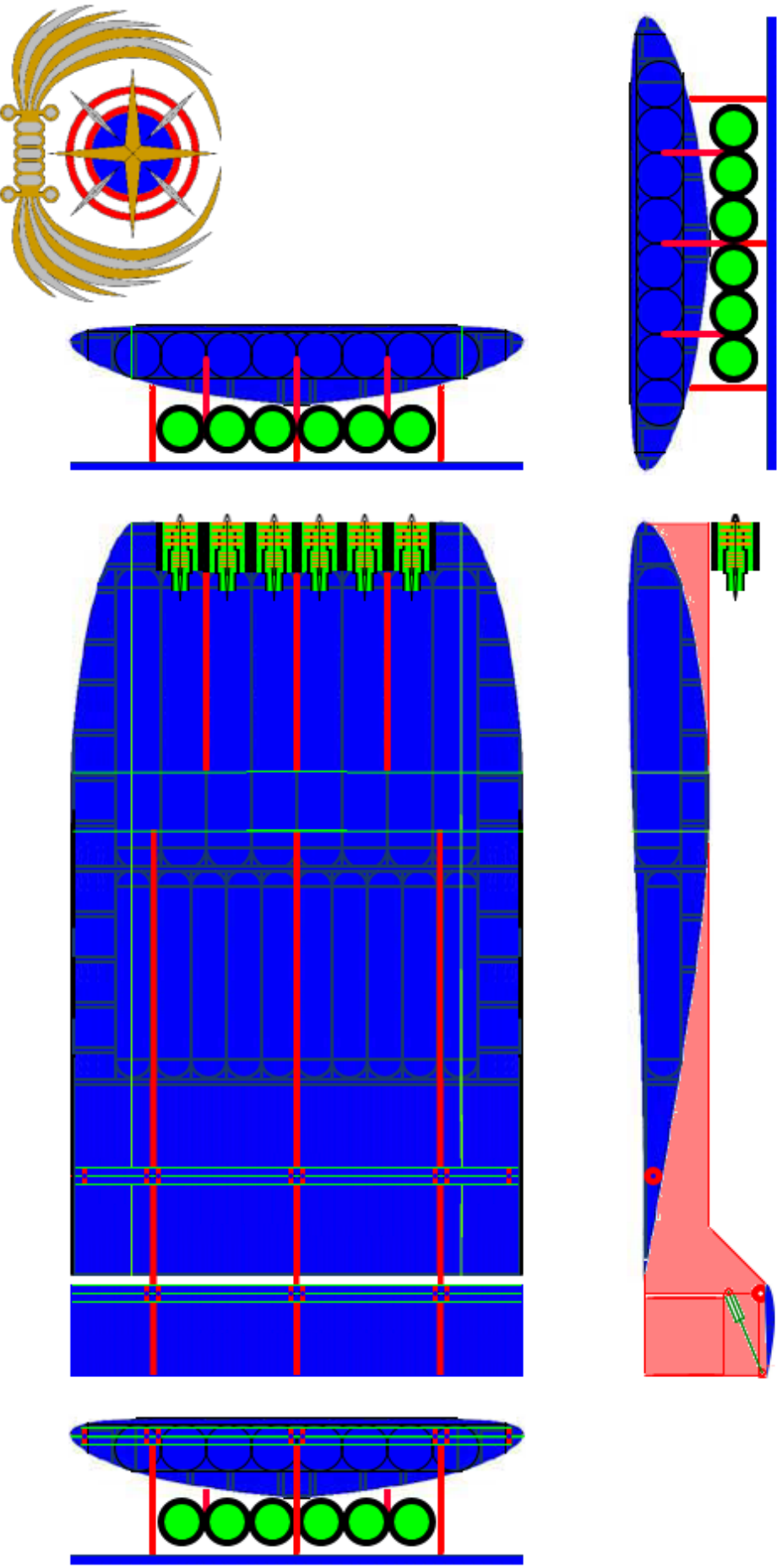

INTERNATIONAL SPACE AGENCY
EXECUTIVE AIRCRAFT DESIGN BY:
ADMIRAL, RICK R. DOBSON, JR.
TRADEMARK & COPYRIGHT 2017
ALL RIGHTS ARE RESERVED



NOTE: DUE TO PROPRIETARY AND INTELLECTUAL PROPERTY ISSUES, THESE
DESIGN DRAWINGS ARE NOT THE FINISHED CONFIDENTIAL ENGINEERING
DRAWINGS WHICH ARE ON FILE AT THE INTERNATIONAL SPACE AGENCY

International Space Agency - I.S.A. / International Space Administration

AIRBUS "TILT TURBO FAN ENGINES" COMPUTER CONTROLLED PITCHABLE PROPS

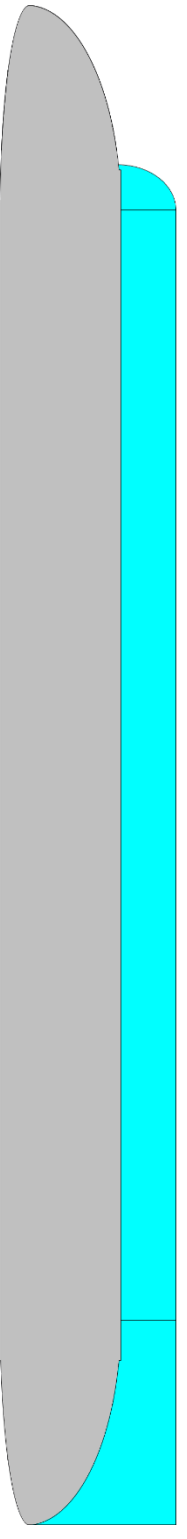
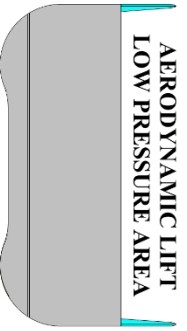
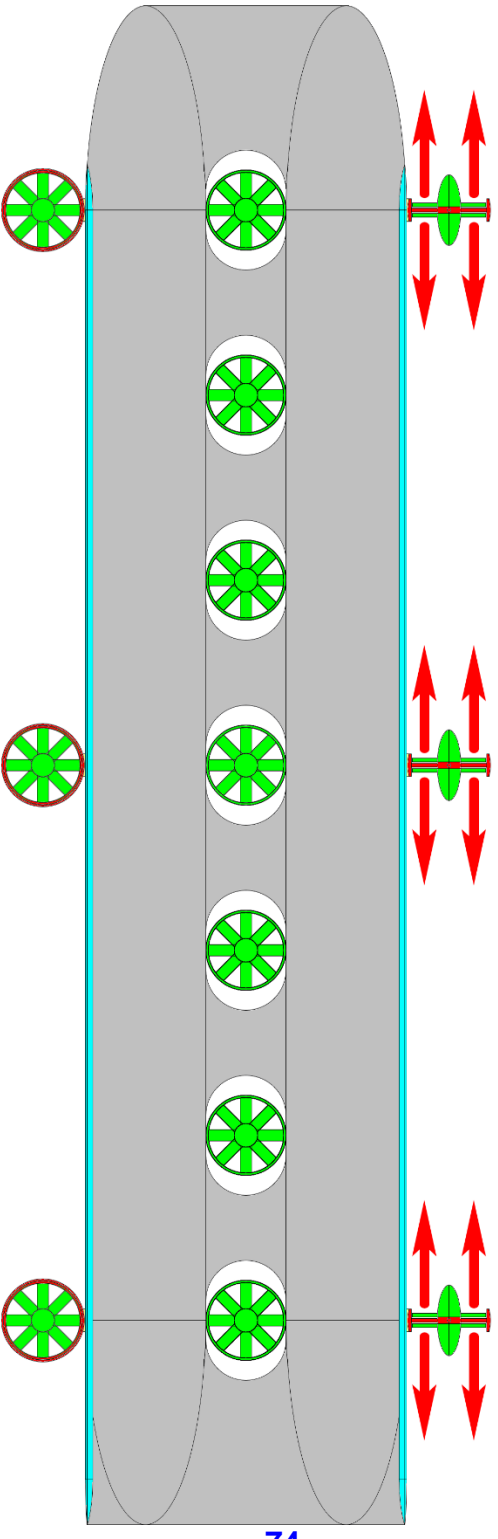
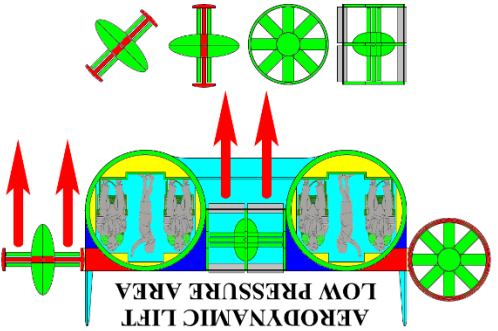
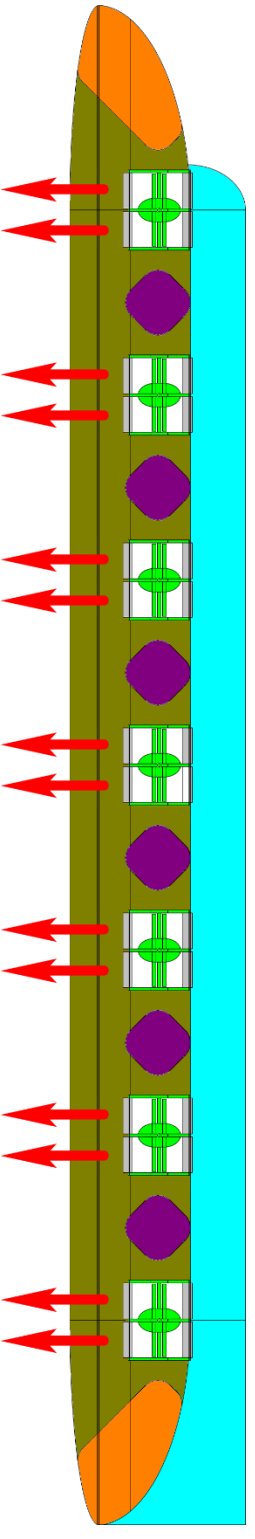
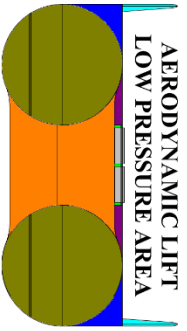

INTERNATIONAL SPACE AGENCY
EXECUTIVE AIRCRAFT DESIGN BY:
ADMIRAL, RICK R. DOBSON, JR.
TRADEMARK & COPYRIGHT 2017
ALL RIGHTS ARE RESERVED

NOTE: DUE TO PROPRIETARY AND INTELLECTUAL PROPERTY ISSUES, THESE DESIGN DRAWINGS ARE NOT THE FINISHED CONFIDENTIAL ENGINEERING DRAWINGS WHICH ARE ON FILE AT THE INTERNATIONAL SPACE AGENCY

International Space Agency - I.S.A. / International Space Administration

AIRBUS "TILT TURBO FAN ENGINES" COMPUTER CONTROLLED PITCHABLE PROPS

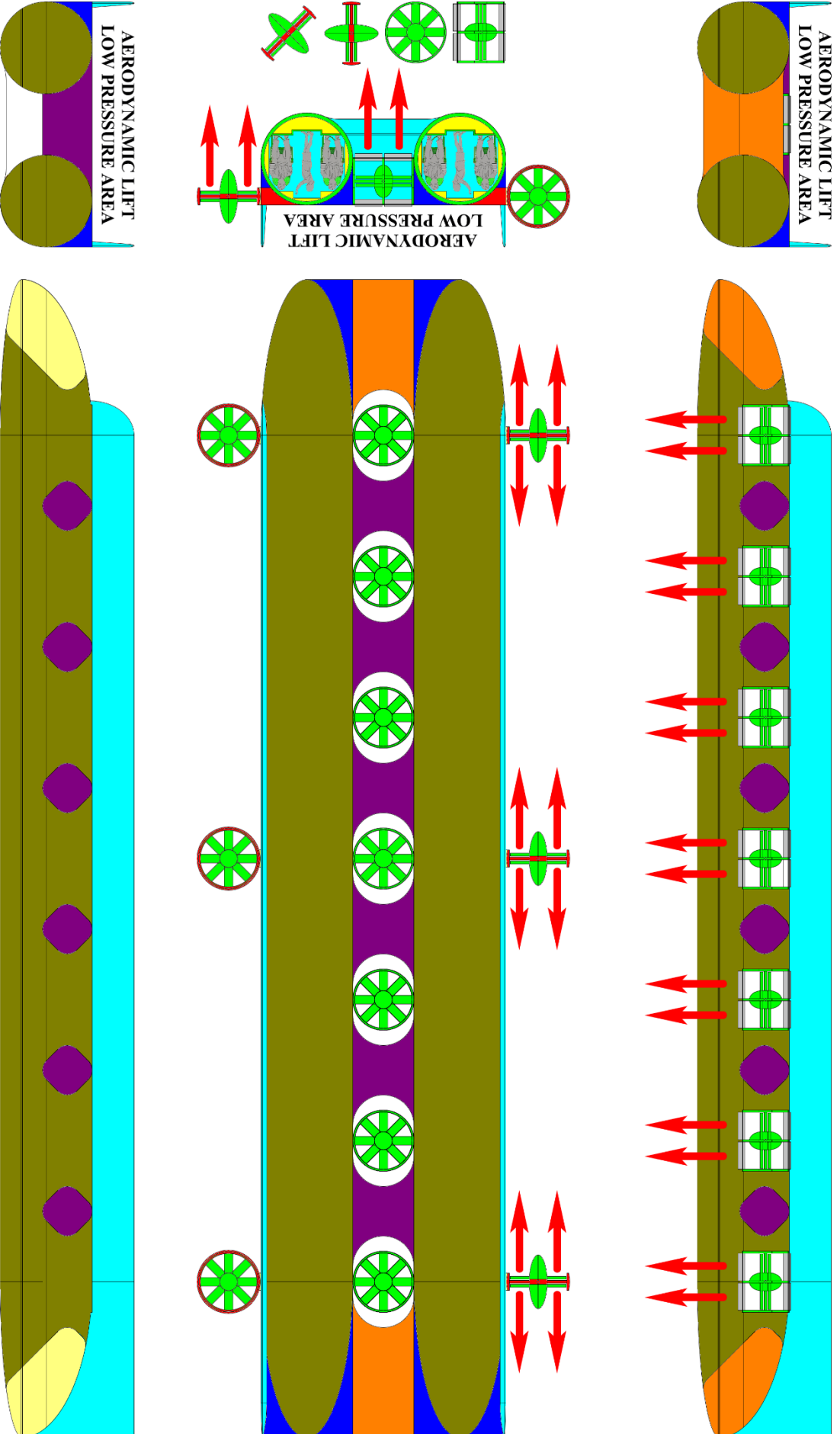

INTERNATIONAL SPACE AGENCY
 EXECUTIVE AIRCRAFT DESIGN BY:
 ADMIRAL, RICK R. DOBSON, JR.
 TRADEMARK & COPYRIGHT 2017
 ALL RIGHTS ARE RESERVED

NOTE: DUE TO PROPRIETARY AND INTELLECTUAL PROPERTY ISSUES, THESE DESIGN DRAWINGS ARE NOT THE FINISHED CONFIDENTIAL ENGINEERING DRAWINGS WHICH ARE ON FILE AT THE INTERNATIONAL SPACE AGENCY

International Space Agency - I.S.A. / International Space Administration Intercontinental Cruiser "Supersonic" Wide Body - Small Executive Aircraft

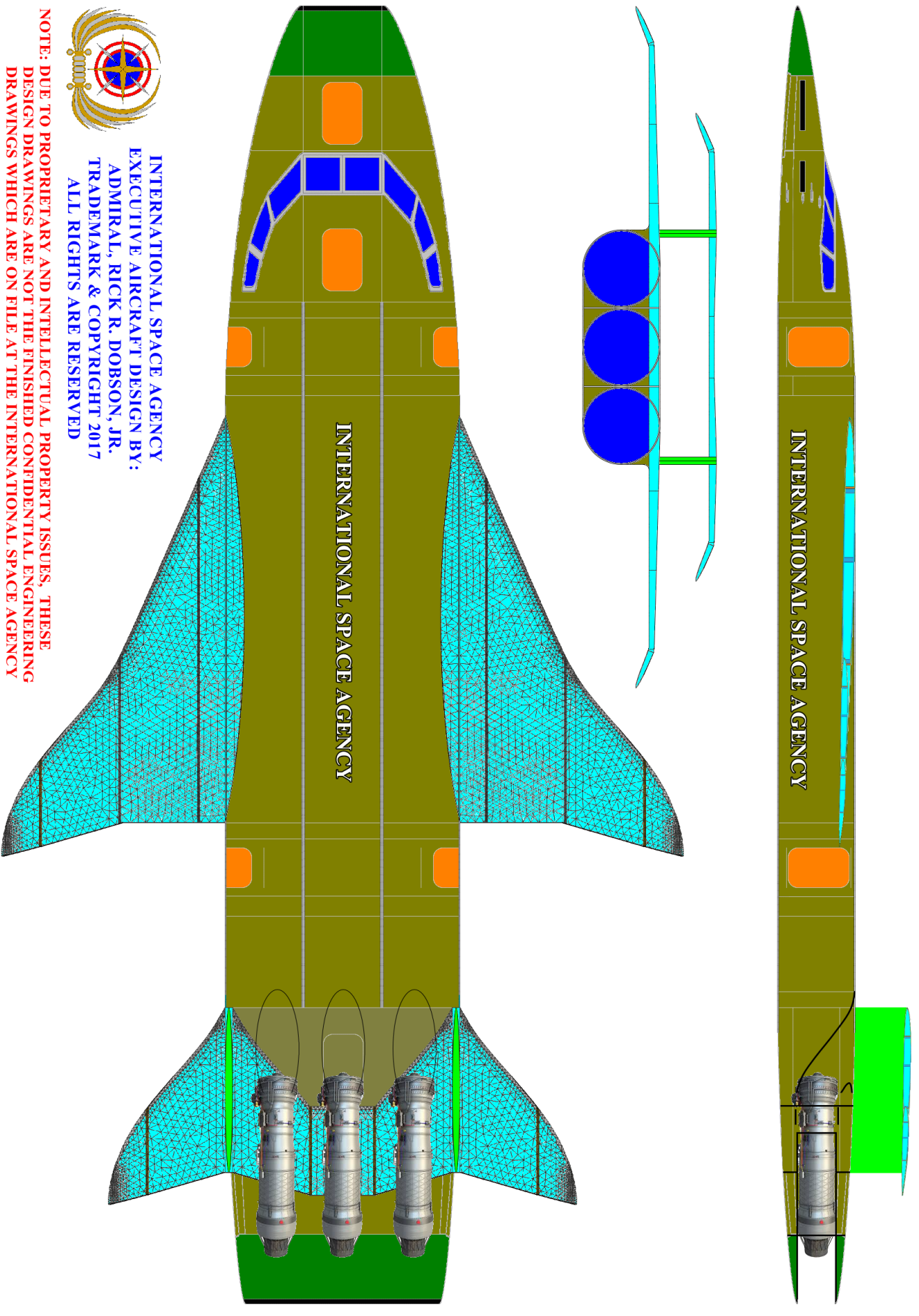

INTERNATIONAL SPACE AGENCY
EXECUTIVE AIRCRAFT DESIGN BY:
ADMIRAL, RICK R. DOBSON, JR.
TRADEMARK & COPYRIGHT 2017
ALL RIGHTS ARE RESERVED

NOTE: DUE TO PROPRIETARY AND INTELLECTUAL PROPERTY ISSUES, THESE
DESIGN DRAWINGS ARE NOT THE FINISHED CONFIDENTIAL ENGINEERING
DRAWINGS WHICH ARE ON FILE AT THE INTERNATIONAL SPACE AGENCY

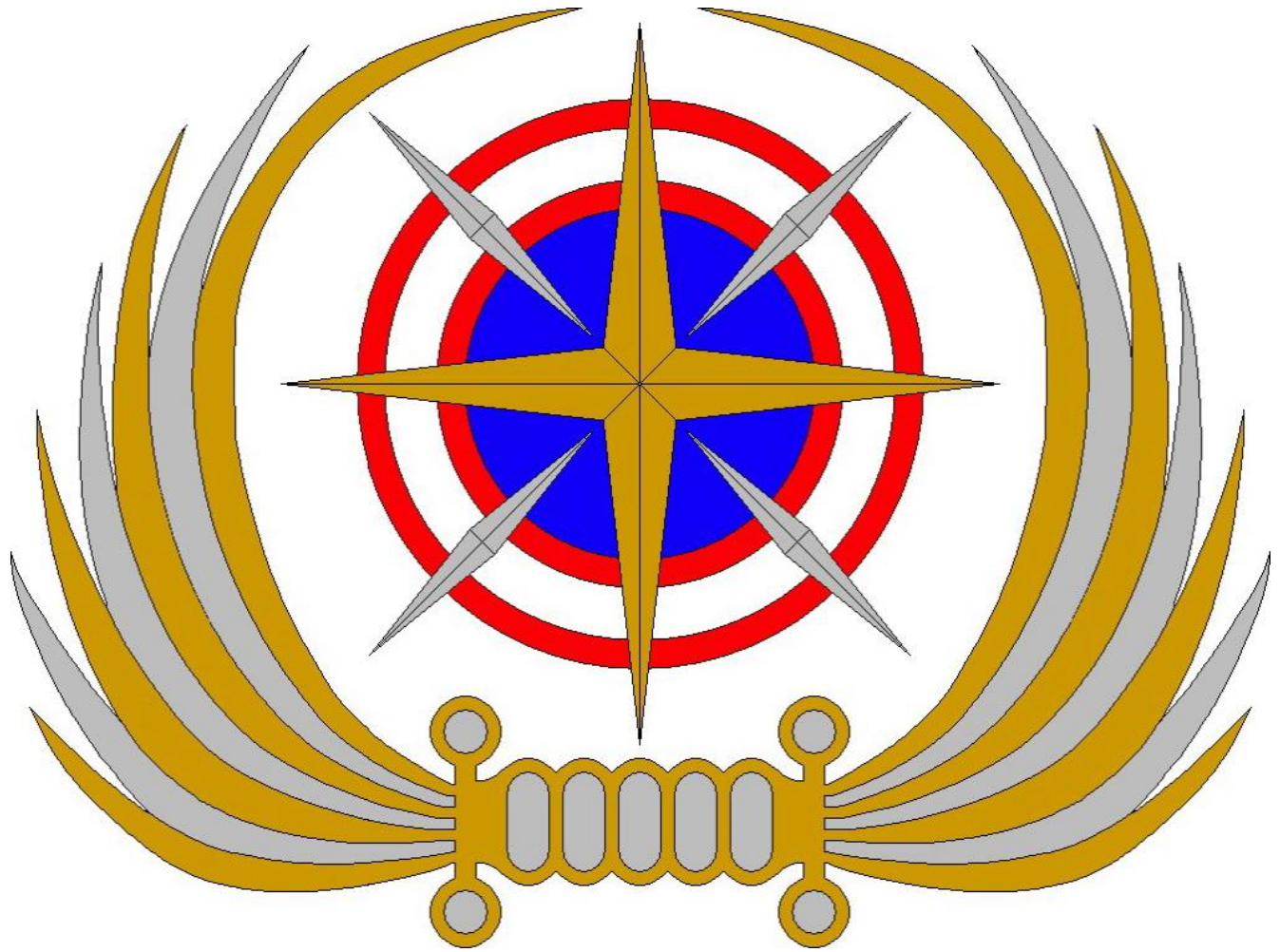

International Space Agency, ISA
International Space Administration
Founded In 1986 -&- Incorporated In 1990
Presently Seeking International Treaty -&- Charter Status

2017 - PROPOSAL

Unified Terrain Standard Time System

“Standard Vibration Frequency (Osculation’s) of a Very Stable Element” that can be “Accurately Measured & Recorded” in a “Controlled Environment”, and be “Maintained Perpetually”; which will be used as an “Extremely Precise Scale Of Measurement” of “Unified” Time & Space based on “Natural Planetary Orbital & Rotational Time & Seasonal Cycles” the “360 Degree Cycle of Orbit” of Earth, or any planets Orbit around the Earths Sun”, and, “360 Degree Cycle of Rotation” of Earth, or any planet/moon around Its Central Rotational Axis”

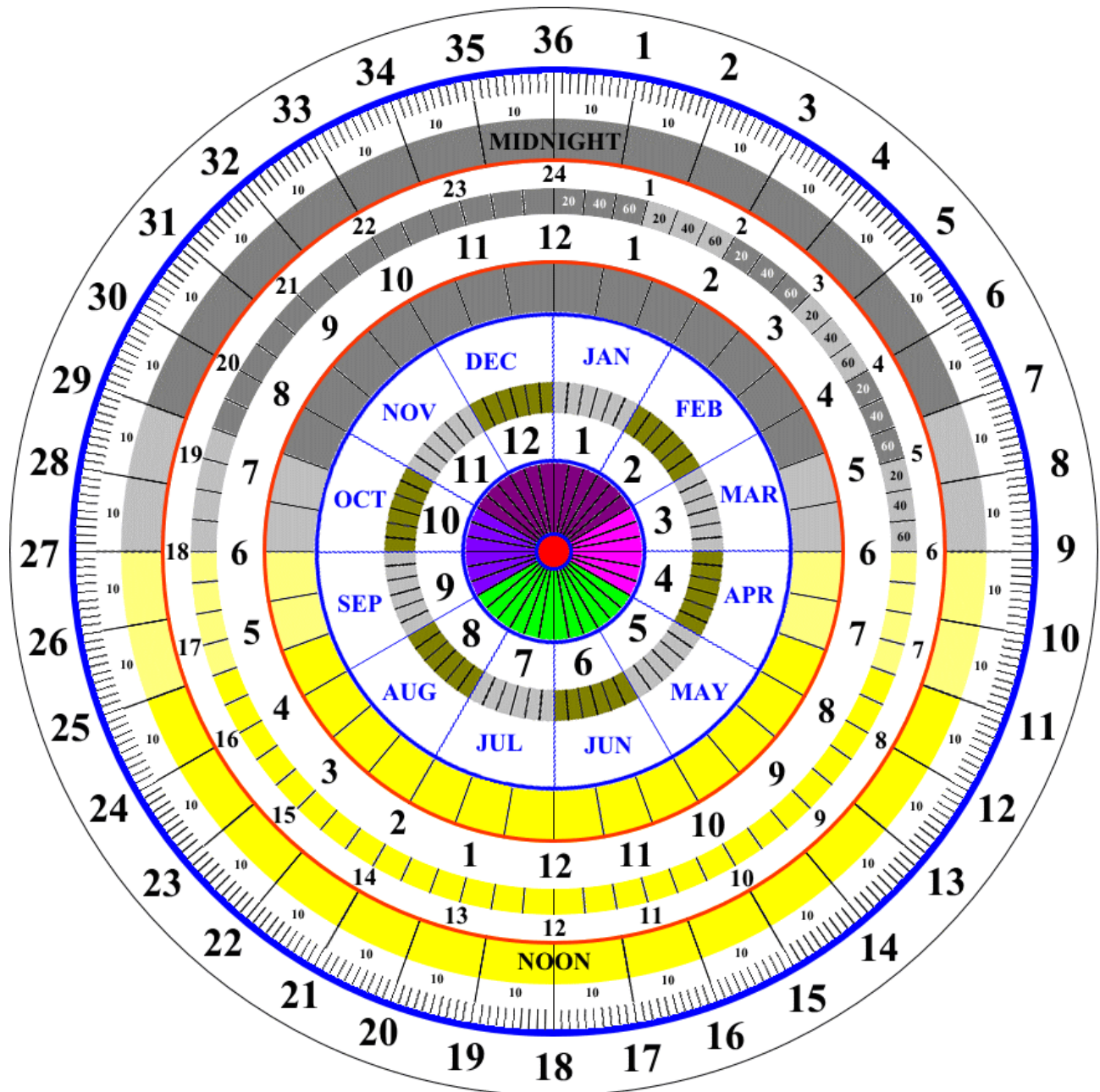

**DIAL FACE - OUTER RIM 36 - TOTAL OSCULATION'S divided by 360 Degrees of Earths Rotation On Its Axis
Earth Day In Terrain Standard Time**

Total Terrain Hours: 36 Total Terrain Minutes: 360 Total Terrain Seconds: 12,960 Total Terrain Parsecs: 129,600

4 Terrain Weeks (+ 2 Terrain Days) in Terrain 30 Day Month

(Earths 360 Degree Orbit Around Sun - 360 Solar Days divided by 12 = 30 Solar Days)

(January 1st Will Be Dialed In At The Exact 360/0 Degree Point Of Earths Orbit Around The Terrain Star "Our Sun")

4 Seasons Per Year: Winter (Nov, Dec, Jan, Feb) / Spring (March, Apr) / Summer (May, Jun, Jul, Aug) / Fall (Sep, Oct)

Terrain Week = 7 Days: Monday, Tuesday, Wednesday, Thursday, Friday, Saturday, Sunday

Last 2 days of every Month Are: DOR "Day Of Rest" -&- DOP "Day Of Peace" (Every Month Ends With A 4 Day Weekend)

36 TERRAIN HOURS per ONE EARTH DAY / 10 TERRAIN MINUTES per TERRAIN HOUR

36 TERRAIN SECONDS per TERRAIN MINUTE / 10 TERRAIN PARSECS per TERRAIN SECOND

(40 Standard Minutes = 1 Terrain Hour)-(4 Standard Minutes = 1 Terrain Minute)-(1 Standard Second = 1.5 Terrain Parsecs)

DIAL FACE - MIDDLE 24 -&- 12AM/12PM - Earth Day In Old 24 Hour Standard Time

Total Standard Hours: 24 Total Standard Minutes: 1,440 Total Standard Seconds: 86,400

**DIAL FACE - CENTER 12 - TOTAL OSCULATION'S divided by 360 Degrees of Earths Orbit Around The Sun
ANNUAL / SEASONAL / 12 Months @ 30 DAY MONTHS**

I. General Information

Project Title:	<i>Unified Terrain Standard Time System</i>
Brief Project Description:	The Terrain Solar System “ Unified Standard Time System ” core element will be based on the standard vibration frequency of a very stable candidate element that can be accurately measured and recorded in a controlled environment, and be so maintained perpetually, and must be able to be copied/duplicated by mechanical or electronic means. These osculation’s will establish a defined scale of measurement in time and space to; exactly calculate the “360 Degree Cycle of Orbit” of any given planet, body, or object’s Orbit around the Star “Sun / SOL” in our Terrain Solar System, and; exactly calculate the “360 Degree Cycle of Rotation” of any given planet, body, or object around Its Central Rotational Axis. Yielding a more precise measurement of TIME & SPACE, for the creation of extremely accurate Clocks & Calendars.
Prepared By:	Mr. Rick R. Dobson, Jr. - United States - Chairman, CEO, Founder, International Space Agency
Date:	4th of October, 2013

J. Project Objectives:

PURPOSE: This first phase of research would establish the exact number of the Osculation’s of the candidate test elements under a controlled environment, to be further used as a precise Time & Space measurement tool. The use of New Materials Research that yields elements/materials that osculate “vibrate” at very specific perpetual rates; and which can be effectively and efficiently emulated by Mechanical Means “Gears & Cams”, or by Electronic Means by imbedding osculating materials components into circuit boards and electronics, which are synchronized and calibrated with Natural Planetary “Rotation & Solar Orbits”. The Research & Development Phase of measuring Earths, or any given Planet in, orbit around our Sun “Sol” would be “3” solar years. This as the results of the first year observations, calculations, data must precisely match the results of the following two years of observations, calculations, data; this is done to achieve full validation and repeated duplication of all observations, calculations, data.

RESEARCH: Specific Areas of Research and Development:

1) Access To NASA Planetary and Solar Orbital Mechanics, Physics, and Scientific Expertise, Satellites, Physical Hardware, Facilities, Computers, and Personnel needed to Precisely Measure, Monitor, Track, and Catalog “Time & Space” the following:

A) Precise Osculation Time Measurement of a 360 Degree Rotation Of Earth On Its Axis “One Full Rotation” Cycle.

B) Precise Osculation Time Measurement of a 360 Degree Orbit Of Earth Around The Terrain Sun “SOL” Cycle.

C) Identification, Research, and Development into Materials that can be used in an Electronic Circuit, that can produce stable, perpetual, and constant vibrations “Osculation’s” at a specific calculated rate, which will be used specifically to measure Space & Time, in relation to **A & B** above.

D) To use advanced scientific calculations and data on a NASA super computer systems, to calculate Material Osculation’s in an Electronic Circuit to calculate exact duration/time of **A & B** above. To analyze all obtained data for the project.

E) To develop an Electronic Circuit Board, that will utilize candidate osculating materials and developed hardware & software to mark/measure/record/display Time & Space at specific “Tempo’s” vibrations “Osculation’s” which will be based on Natural “360 Degree Rotational & Solar Orbital” characteristics “Cycles/Phases” of Earth “Other Planets” in relation to the Terrain Star, our Sun.

F) To use the developed data, hardware, software of this Research & Development project to manufacture Machines and Electronic Devices that can display time and dates “**360-36/10/36/36**” -&- “**365-24/60/60/60**” in direct relation to Natural “Rotational and Solar Orbital” characteristics “Cycles/Phases” of Earth in relation to the Terrain Star, our Sun, and based on specific material osculation’s.

BENEFITS: This will establish specific natural occurring Planetary/Moon cycles & phases in time measurement systems based on a specific **36 Terrain Hours Per Day, with each Terrain Hour having 10 Terrain Minutes, with each Terrain Minute having 36 Terrain Seconds, with each Terrain Second having 36 Terrain Parsecs**, which will translate/convert easily into a **24 unit measure of time (Hours), broken into 60 sub units (Minutes), and broken into 60 sub units (Seconds)**, based on the exact osculation’s per one exact planet or body “moon” rotation around its central axis of rotation “One Full Day” This as the historic recognition of these systems in the Human Society & Mind would already be in use, so conceptually there would be little change, only in the core base line of time & space based on uniform osculation’s in relation to Planet Rotations & Solar Orbits. This will be the fundamental foundation for a NEW and much more Accurate and Precise Terrain Solar System “Unified Terrain Standard Time/Calendar System”. This new system for tracking, measuring, utilizing TIME & SPACE will be much more in tune/sync with the cycles and phases of the natural world, creation. This new and more advanced “Unified Terrain Standard Time/Calendar System” will enhance rapidly advancing computer technologies, greatly support agricultural efforts in seasonal calendars, and help usher in the New Space Age of travel to and from planets/moons in our Solar System. (**See Attached Terrain Clock/Calendar Dial Face**)

FUNDING: \$500,000 Grant or Donation to Fund Management, Staffing, Facilities, Materials for a “3” year research project to research and develop a “New Perpetual Osculation’s Based Time/Calendar Measuring System” leading to creation of a “Unified Terrain Standard Time/Calendar System”. Funding or Grant Funds will be managed by the International Space Agency Corporation.

Unified Terrain Standard Time System

A “New Unified Time System” to account for Natural Planetary “360 Degree Rotational and Solar Orbital” Cycles / Rhythms / Phases, and to accommodate Space Travel and Habitation, in Space, to/and, “ON” other Planets -&- Moons in the Terrain Solar System.

Copyright © 1988 - By: Admiral, Rick R. Dobson, Jr., Chairman & CEO, International Space Agency
International Space Agency: Name, Public Identity, Logo, Emblem: Are: USA Registered ®: Trademark™ & Copyrights ©, 1986-2015, All Rights Reserved
International Space Agency, P.O. Box 541053, Omaha, Nebraska 68154 - (402) 299-2799

The Terrain Solar System “Unified Standard Time System” core element will be based on the standard vibration frequency of a very stable element that can be accurately measured and recorded in a controlled environment, and be so maintained perpetually, and must be able to be copied/duplicated by mechanical or electronic means. These osculation’s will establish a defined scale of measurement in time and space. Using the present level of NASA, Space Technology, Orbital Physics & Mechanics, which can exactly calculate the “360 Degree Cycle of Orbit” of any given planet, body, or object’s Orbit around the Star “Sun / SOL” in our Terrain Solar System. Also, using the present level of NASA, Space Technology, and Orbital Physics & Mechanics; which can exactly calculate the “360 Degree Cycle of Rotation” of any given planet around Its Central Rotational Axis.

These 3 specific elements will be the Base Line “Foundation” for a new “Unified Terrain Standard Time System”:

- 1) “standard vibration frequency (osculation’s) of a very stable element”,** that can be accurately measured and recorded to establish an extremely precise “*Exact Scale of Measurement*” of unified time and space, that will be exactly the same no matter where in the Terrain Solar System an observer “Person or Object” would be located, and based on natural occurring 360 Degree Orbital Cycles.
- 2) Using the present level of NASA, Space Technology, Orbital Physics & Mechanics,** which can exactly calculate the “360 Degree Cycle of Orbit” of any Planet around its Central Star in the Terrain Solar System.
- 3) Using the present level of NASA, Space Technology, and Orbital Physics & Mechanics;** which can exactly calculate the “360 Degree Cycle of Rotation” of any given planet or moon around Its Central Rotational Axis.

The measurement of time and seasons “*Clocks & Calendars*”, that would be based on the “*Natural Planetary Time and Seasonal Cycles*” that are precise and unchanging; and unlike the time and seasonal systems presently in use, would be in exact phase alignment, harmony, pace with planetary solar orbital & planetary rotational cycles. June 13th 2017 would be exactly in solar orbital phase alignment with June 13th 2027, ect. “**Ie: No Leap Year’s and no constant recalculations to realign the present time and seasonal measuring systems as they phase out of sync with natural planetary solar orbital and planetary rotational cycles.**”

This is a fairly straight forward concept and enterprise, “all be it” an extremely sophisticated, precise, exact endeavor that requires the skilled use and application of very advanced space technology, knowledge, materials.

The **Research & Development Phase** of measuring Earths, or any given Planet in, orbit around our Sun “Sol” would be “**3” solar years**. This as the results of the first year observations, calculations, data must precisely match the results of the following two years of observations, calculations, data; this is done to achieve validation and repeated duplication of all observations, calculations, data.

First phase of research would establish the exact number of the osculation’s of the test elements under controlled environment. **Just for a base example of the concept, Hypothetically,** lets say the test elements under controlled environment osculated a total of **94,672,800** Osculation’s per one complete orbit of Earth around the Sun “**Or**

Any Planet in Orbit around Our Sun” ie: **Standard Solar Year** Measured & calculated from the actual rotational axis, center, of the Earth. This number of Exact Osculation’s would be divided by “12” to align with present established annual “Yearly” seasons and months presently in historic use by Humans on Earth. Giving an established base line of osculation’s of a 1/12th Cycle of Solar Orbit or “Month / 30Days”

Example:“Year” 94,672,800 divided by “12/Months”=7,889,400 And then: 7,889,400 divided by “30/Days”= 262,980

So, A Planet Solar Year Is= Total Osculation’s = 94,672,800

A Planet Solar Month Is= Total Osculation’s = 7,889,400

A Planet Solar Day Is= Total Osculation’s = 262,980

And, the test elements under controlled environment osculated a total of 94,672,800 times per “365.25”? complete rotations of the Earth. (**The total exact rotations of Earth as it makes one exact orbit around our Sun “SOL” is required?**) “Planet Solar Day” Measured from a fixed point at the Earths Equator and calculated from the actual center of rotational axis of the Earth, as it completes one exact full Orbit around our Sun “SOL”. **Planet Solar Year** of 94,672,800 Osculation’s divided by “365.25”? = 259,200 Osculation’s. “ACTUAL” **Exact Planet Rotations in one Solar Orbit of the Sun “SOL”** would be 259,200 Osculation’s. So with the “Planet Solar Day” being: 262,980 Osculation’s; And the “ACTUAL” **Exact Earth Rotations** in one Exact Solar Orbit being: 259,200 Osculation’s. Therefore, the difference between the two cycles is 3,780 Osculation’s (**21 Minutes**)

“Ref. 1” The hypothetical difference in the two cycles is: 3,780 Osculation’s (or 21 Minutes) difference in one Solar Year. With this calculation of 3,780 Osculation’s difference “Out of Phase” between **Earth Solar Day 262,980** Osculation’s and **Earth Rotational Day 259,200** Osculation’s, the “Unified Terrain Standard Time System & Calendar” would have to be recalibrated only every **68. 571,428,571,428** Years by “Only One Day”. This recalibration every **68. 571** Years can be increased in relation to the Base Vibration of Osculation’s of “3 osculation’s per second” ratio is increased in magnitude. **For example**, if a material is identified that has a stable perpetual vibration Osculation’s of “9 osculation’s per second” ratio, then the recalibration of **68. 571 Years** will be increased by a magnitude of “3”, or 3 x **68. 571 Years** = “The Recalibration of One Day every: **205. 714 Years.**”

The actual exact total osculation’s in one exact rotation of the Earth is “unknown” until an exact measurement of osculation’s per “One Earth Rotation” has been achieved, and completed. Once this “Standard Earth Day” has been established, it will be compared with the “Planet Solar Day” and the differences “Data” between the two will be calculated and analyzed. And then compared with “Ref. 1” above. The numbers above are purely hypothetical, and used only as examples of how precise calculated osculation’s in relation to Natural Planet Rotations and Planet Solar Orbits would be calculated and used in the NEW “Unified Terrain Standard Time System”.

Let’s just assume a hypothetical calculation of “259,200“ Osculation’s in one exact rotation of the Earth on its rotational axis. We divide 259,200 by 24 which equals “One Hour” or: 10,800 Osculation’s. We then divide 10,800 by 60 which equals “One Minute” or: 180 Osculation’s. We then divide 180 by 60 which equals “One Second” or: 3 Osculation’s. Once this research study, calculations, and observations are completed after the 3 year “3 Solar Obits”, the test materials osculation’s data will be analyzed and used in establishing a more precise Unified Terrain Time System, that will be able to be used any where in the Solar System, and will be cohesive in its use across the planets and spaces of the Terrain Solar System, and beyond.

This will establish specific natural occurring Planetary and Moon cycles and phases in time measurement systems based on a specific 24 unit measure of time (Hours), broken into 60 sub units (Minutes), and broken into 60 sub units (Seconds), based on the exact osculation’s per one exact planet or body “moon” rotation around its central axis of rotation “One Full Day” This as the historic recognition of these systems in the Human Society and Mind would already be in use, so conceptually there would be little change, only in the core base line of time & space

based on uniform osculation's in relation to Planet Rotations and Solar Orbits. This time system will be specific to any planet or body "moon" on which the observer "Person/Object" is physically "On". The time cycle of Earth will be referred to as "**Earth Standard Time**" and will be used on all habitation, surface bases, orbital facilities, and ships in orbit and deep space, of Earth, Earths Moon, and all Deep Space and Non-Orbital Space in the Terrain Solar System and Beyond, in the **Unified Terrain Standard Time System**. The Earth Solar Year, Earth Solar Month, and Earth Solar Day will also apply to these areas. Once an Observer "Ship, Person, Object" leaves these areas and actually makes contact with, lands "On" or is "On" another Planet or Moon in the Solar System, the Planet Solar Year, Month, Day of the Unified Terrain Standard Time System of that specific Planet or Moon will take precedence to "Earth Standard Time". However, all official records anywhere in the Solar System or Beyond, will be based on "Earth Standard Time" of the Unified Terrain Standard Time System. This will keep record keeping, data, and archives uniform, with out the mess of interjecting many different planetary and moon time and seasonal differences. It will also help to plan seed planting and crop harvesting time tables in the Agricultural Community Globally.

Example: A ship and crew from Earth lands and stays on Mars, and are operating Locally on Mars Standard Time, and during this mission all reports, computer, and communications time stamped data are in Earth Standard Time. Then they travel to the Earths Moon. Reports by the crew in Space, In Mars Orbit, On the Mars Surface, and in Earths Moon Orbit are all locked into a central "Unified Terrain Standard Time System". By doing this for all record keeping, data, and archives it will not become a mixed up and confused mess as they will all conform to a central "Unified Terrain Standard Time System". However, as the crew stays on the Mars Surface, their watches, clocks, and seasonal calendars would be on Mars Standard time. All communications and computer data bases time stamp and internal clocks and calendars would be on Earth Standard Time of the Unified Terrain Standard Time System. If your ON the Moon, or ON Mars, the time systems will all still be 360/24/60/60 except that the actual duration "In Standard Osculation's" of an Hour on Earth will be different than an Hour on Mars. But from the mind of the Observer a system of Years, Months, Days, Hours, Minutes, Seconds will be conceptually the same. Example, if your boss on Earth says be at work at 9 AM on March 21st, it is the very same as if your boss on Mars said be at work at 9:30 AM on March 21st. The only difference will be that on Earth Local it might be the year 2017 and on Mars Local it might be 2037. There is no way around this one issue, as the Planets and there Moons Orbit at different speeds/cycles around the sun. On the Earth "Earth's Moon" Local it might be the 7 PM on the 4th of July 2017 and on Mars "Phobis" Local it might be 3 AM on the 18th of November 2036. However the "Unified Terrain Standard Time and Date on Both Earth and Mars would be: 7 PM on the 4th of July 2017. **For Example**, if you had a business or government transaction on Earth and Mars at the same spatial time, the Transaction on Mars would list both Local Mars Standard Date & Calendar Stamp and Earth Standard Date and Calendar Stamp. So if in 10 Planet Calendar Years/Months/Days/Time on Local Mars and Local Earth, they will no longer be the same, and now out of sync with the original transaction. So if a Government, Corporation, Agency, or Person wants to access this transaction in databases it would be exclusively in Earth Standard Time & Calendar, which will be in the same Spatial Time and Calendar Date of the "**Unified Terrain Standard Time System**".

The use of New Materials Research that yields elements/materials that osculate "vibrate" at very specific perpetual rates; and which can be effectively and efficiently emulated by Mechanical Means "Gears & Cams", or by Electronic Means by imbedding materials into circuit boards and electronics, which are synchronized and calibrated with **Natural Planetary "Rotation & Solar Orbits"**. This will be the fundamental foundation for a **NEW** and much more **Accurate and Precise** Terrain Solar System "**Unified Standard Time/Calendar System**". This new system for tracking, measuring, and utilizing **TIME & SPACE** will be much more in tune/sync with the cycles and phases of the natural world, creation. This new and more advanced "Unified Standard Time/Calendar System" will enhance rapidly advancing computer technologies, greatly support agricultural efforts, and help usher in the New Space Age. The Human perception of **TIME & SPACE "Time Clock & Seasonal Calendar Systems"** has evolved over the last 5000 years as humans discovered and adapted to these natural cycles of **TIME & SPACE** around them. Now with modern advances in space sciences, technology, astronomy, the sophisticated precise observations and understanding of these natural cycles has also evolved.

A NEW Natural System of *TIME & SPACE* “Unified Terrain Standard Time System”

Is An Idea Whose “*TIME*” Has Come!

Unified Terrain Standard Time System

A “New Unified Time System” to account for Natural Planetary “360 Degree Rotational and Solar Orbital” Cycles/Rhythms/Phases, and to accommodate Space Travel and Habitation, in Space, and/to, ON other Planets and Moons in the Terrain Solar System.

Copyright © 1988 - By: Admiral, Rick R. Dobson, Jr., Chairman & CEO, International Space Agency
International Space Agency: Name, Public Identity, Logo, Emblem: Are: USA. Registered ®: Trademark™ & Copyrights©, 1986-2015, All Rights Reserved

International Space Agency, P.O. Box 541053, Omaha, Nebraska 68154 - (402) 299-2799

Research Grant Proposal For The International Space Agency Requested Research Elements & Resources

1) Access To NASA Planetary & Solar Orbital Mechanics, Physics, and Scientific Expertise, and Satellites, Physical Hardware, Facilities, Computers, and Personnel needed to Time, Monitor, Track, and Catalog the following:

A) Exact 360 Degree Rotation Of Earth On Its Axis “One Full Rotation” Cycle.

B) Exact 360 Degree Orbit Of Earth Around The Terrain Sun “SOL” Cycle.

C) Identification, Research, and Development into Materials that can be used in an Electronic Circuit, that can produce stable, perpetual, and constant vibrations “Osculation’s” at a specific calculate rate, which will be used specifically to measure Space & Time, in relation to A & B above.

D) To use advanced scientific calculations and data on a NASA super computer systems, to calculate Material Osculation’s in an Electronic Circuit to calculate exact duration/time of A&B above. To analyze all obtained data for the project.

E) To develop an Electronic Circuit Board, that will utilize candidate osculating materials and developed hardware & software to mark/measure/record/display Time & Space at specific “Tempo’s” vibrations “Osculation’s” which will be based on Natural “Rotational & Solar Orbital” characteristics “Cycles/Phases” of the Earth “Other Planets” in relation to the Terrain Star, our Sun “SOL”.

F) To use the developed data, hardware, and software of this Research and Development project to manufacture Machines and Electronic Devices that can display time and dates “360/24/60/60” in direct relation to Natural “Rotational and Solar Orbital” characteristics “Cycles/Phases” of the Earth in relation to the Terrain Star, our Sun “SOL”, and based on specific material osculation’s.

2) \$500,000 Grant to Fund Management, Staffing, Facilities, Materials for a “3” year research project to research and develop a “New Time/Calendar System” leading to creation of a “Unified Terrain Standard Time/Calendar System”.

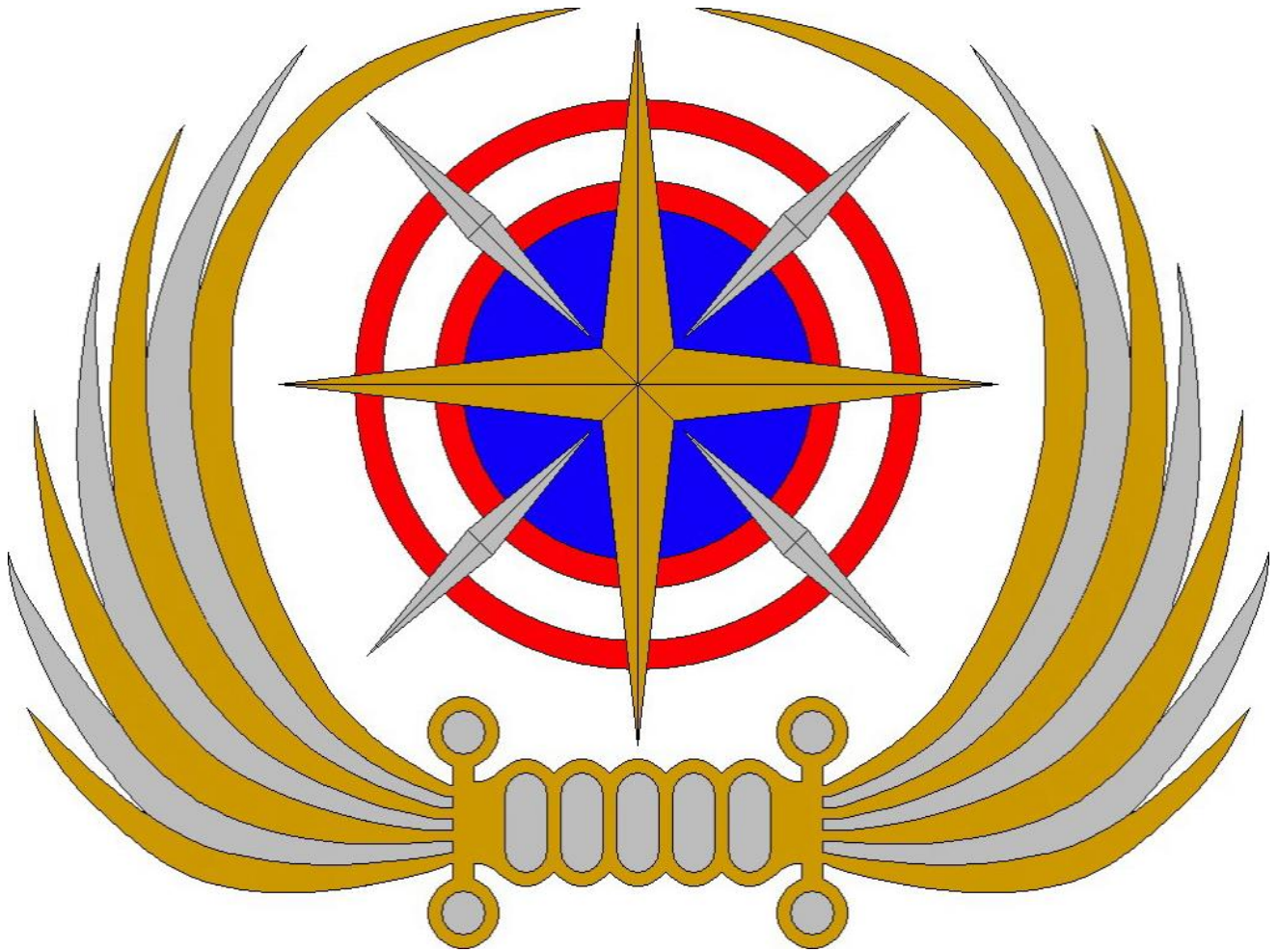

International Space Agency, ISA
International Space Administration
Founded In 1986 -&- Incorporated In 1990
Presently Seeking International Treaty -&- Charter Status

2013 - PROPOSAL

CLOSED LOOP INERTIAL MASS PROPULSION SYSTEM

PROTOTYPE: RESEARCH / DEVELOPMENT / PRODUCTION

Solid Mass Mechanical (S.M.M.)

Centrifugal Propulsion System (C.P.S.) Program / Office

International Advanced Space Propulsion (I.A.S.P.) Programs / Office



International Space Agency , I.S.A. International Space Administration

Purpose: The Solid Mass Mechanical (S.M.M.) Centrifugal Propulsion System (C.P.S.) Program / Office (P.O.) will function as an important operational department, center, and program office of International Space Agency, and will be a catalyst and enabler to facilitate and support all research and development, for advanced space propulsion, technology, and programs, and act as the central management of Advanced Space Propulsion Capabilities, and Services, Facilities, and Hardware that will be directly or indirectly supporting the vision and mission of the International Space Agency Organization and its Operational Divisions, Departments, Centers, and Commands. SMM-CPS-PO will also be the command and control authority of all Closed Loop Propulsion Research and Development Efforts and Activities of the International Advanced Space Propulsion (I.A.S.P.) Program / Office, and will include the collective personnel resources of SMM-CPS-PO Officers, Management, Technicians, and Staff. SMM-CPS-PO will support and carry out all Research & Development of Closed Loop Propulsion Capabilities for advanced international space technology programs, projects, missions, and advanced international space research and development activities, for the ISA, and its member states & organizations, and Globally as approved by its members. SPECIFICALLY: CLOSED LOOP PROPULSION TECHNOLOGY

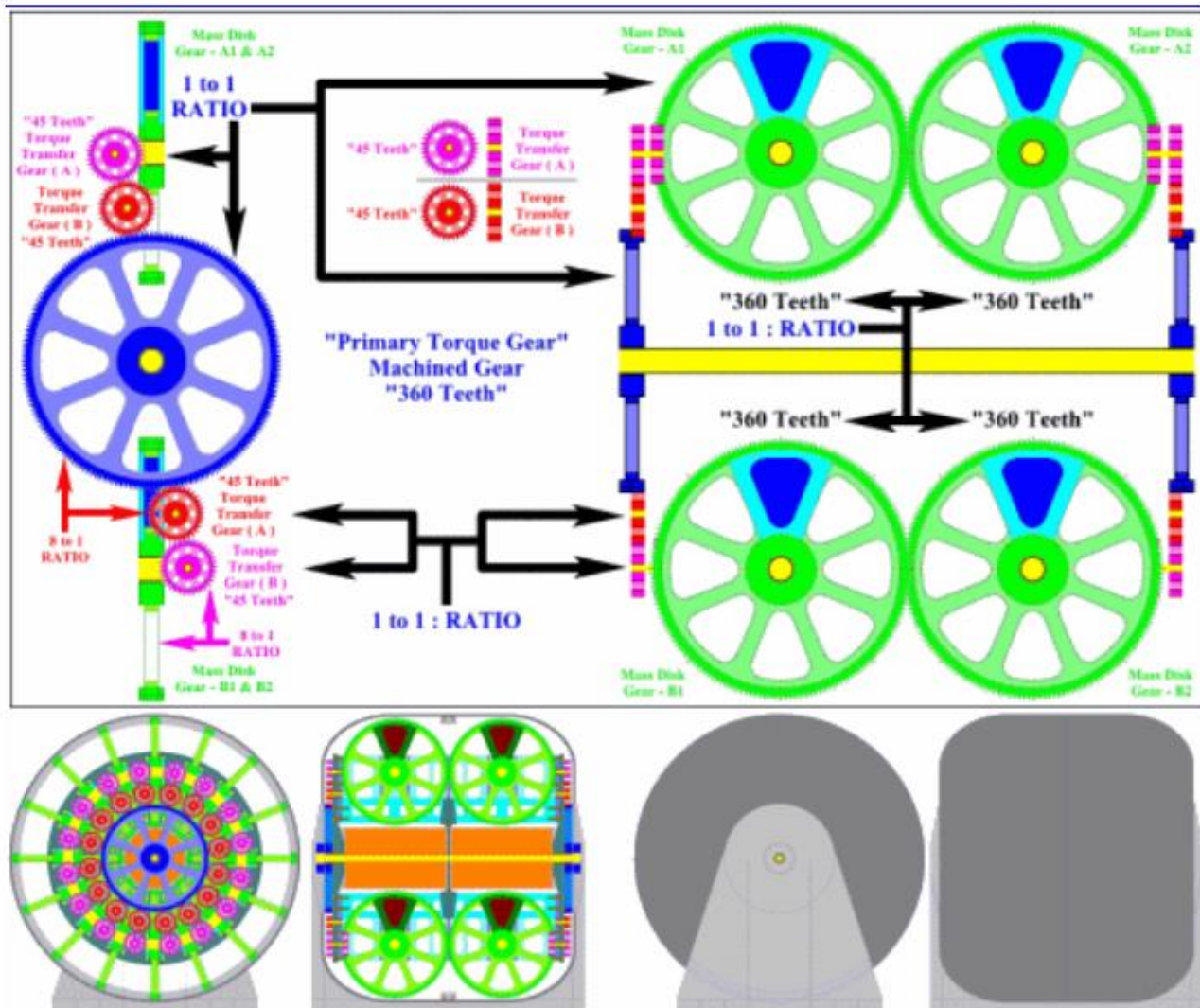

Solid Mass Mechanical (S.M.M.) Centrifugal Propulsion System (C.P.S.) Program

International Space Agency, I.S.A.: Name, Public Identity, Logo, Emblem: Are: U.S.A. Registered®: Trademark™ -& Copyrights©, 1986-2017, All Rights Reserved
United Space Federation, U.S.F.: Scientific -& Aerospace/Research -& Development / Non-Profit Corporation / Incorporated 1990 / New York State / United States

K. General Information

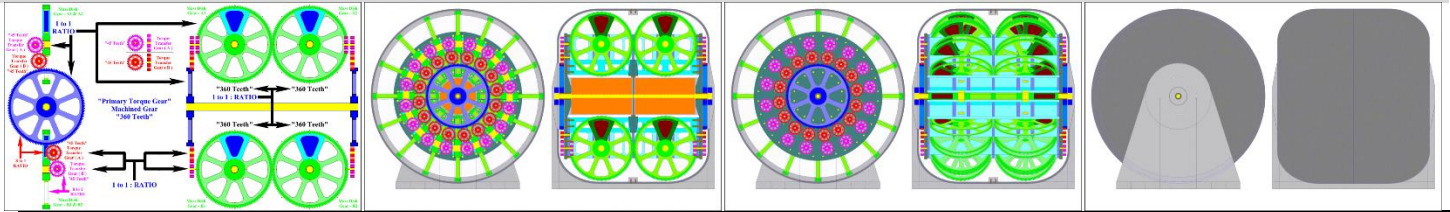

Project Title:	Solid Mass Mechanical (S.M.M.) Centrifugal Propulsion System (C.P.S.) Program / Office Operations & Programs / Research & Development An Internal Department of the International Advanced Space Propulsion (I.A.S..P) Programs / Office
Brief Project Description:	SMM-CPS-PO will support and carry out all Research & Development of Closed Loop Propulsion Capabilities for advanced international space technology programs, projects, missions, and advanced international space research and development activities, for the International Space Agency , and its member states and organizations, and Globally as approved by its members. Specifically "Closed Loop Propulsion" Technology.
Prepared By:	Dr. Thorsteinn Olafsson – Iceland Director, Solid Mass Mechanical (SMM) Centrifugal Propulsion System (CPS) Program / Office, I.S.A. Mr. Rick R. Dobson, Jr. - United States – Founder, Chairman, CEO, International Space Agency
Date:	15th of October, 2013

L. Project Objectives:

PURPOSE: The **Solid Mass Mechanical (S.M.M.) Centrifugal Propulsion System (C.P.S.) Program / Office (P.O.)** will function as an important operational department, center, and program office of International Space Agency, and will be a catalyst and enabler to facilitate and support all research and development, for advanced space propulsion, technology, and programs, and act as the central management of Advanced Space Propulsion Capabilities, and Services, Facilities, and Hardware that will be directly or indirectly supporting the vision and mission of the International Space Agency Organization and its Operational Divisions, Departments, Centers, and Commands. **SMM-CPS-PO** will also be the command and control authority of all **Closed Loop Propulsion Research and Development Efforts and Activities** of the **International Advanced Space Propulsion (I.A.S.P.) Program / Office**, and will include the collective personnel resources of **SMM-CPS-PO** Officers, Management, Technicians, and Staff. **Note: Proprietary Research & Schematics has already been achieved.**

CAPABILITY: Solid Mass Mechanical (SMM) Centrifugal Propulsion System (CPS) is a technology that harnesses the inertia effect found in high rotational bodies "Mass", which leads to forward thrust and does not require finite mass to be ejected in the opposite direction; like presently found in chemical rocket nozzles or jet engines, in order to produce thrust. This is therefore a **"Closed Loop Propulsion System"** which means that it does not require finite mass to be ejected in the opposite direction to produce forward thrust, as is presently the case in all conventional propulsion systems in use today. This discovery will revolutionize space travel, by enabling us to explore our solar system in more efficient manner. Chemical Rockets "Disposable Ejected Finite Reaction Mass" will not provide effective propulsion capabilities for travel over the great distances between Planets, with in the vast spaces of the Solar System, and Beyond. Therefore, it is critical, paramount, that a NEW form of "Closed Loop Propulsion" be researched & investigated, with the focus to be developed.

The discovery of these mathematical inertia formulas, will lead to detailed explanations for **"Closed Loop Propulsion"** effect. These mathematical equations and explanations once available, will at the same time, explain other things within physics, which so far have not been properly understood. It is a closer approach to what is really taking place in Orbital Mechanics, Electron Orbits in Atoms, and Electron Emissions from High Rotational Bodies "Like A Star". At the same time these discoveries will lead to the fact, that it will be possible to harness this effect, and then in a much more efficient manner produce constant thrust for long durations for long distant travel between planets, and with in the vast spaces of our Solar System, and beyond. In the Centrifugal "Inertial" Propulsion System, the **"REACTION MASS"** is suspended in a **"Dobson Centrifugal Field"**, and this **"Energy/Mass Suspended in a High Rotational Field"**, This **"Rotary Mass / Energy"** is then converted to **"Linier Mass / Energy-Thrust"**. Therefore, the finite reaction mass is not EJECTED out the rear of the propulsion system like in all propulsion systems presently in use today. In a "Closed Loop Propulsion System", the reaction mass is reused perpetually, and is suspended/stored in a high rotational field.

In this regards, the propulsion device is causing a synchronized and directionally focused disruption or imbalance with regards to the center of rotational mass within the given object or device, therefore leading to forward thrust or propulsion. If we go further into this the imbalance and the forward thrust and movement is directly related to the physics properties found in the Higgs-Field itself. The Higgs-field has on the other hand to do with properties that are linked to dark energy. Such calculations concerning this need to be further explored and defined. Funding will be required to bring this advanced technology about, and then to develop it fully.

BENEFITS: The Centrifugal "Inertial" Propulsion System will provide Constant & Perpetual Thrust as long as electrical power is supplied to its electric drive motors in the case of the use of Solid Mass and Mechanical Means; or its electromagnetic repulsor drive elements in the case of the use of Liquid "Metal" Mass and Magnetic Containment and Suspension Means. All reaction mass would be perpetually "suspended" and self-contained with in the propulsion system. This will allow travel over vast distances in space.

FUNDING: A Single or Combined, Grant or Donation, in the sum of One Million U.S. Dollars (\$ 1,000,000) is sought, to fund a 3 year Classified Research and Development Program, to obtain key Scientific & Engineering Personnel, Facilities, Equipment, and Materials required to research, conceive, develop, and build a fully operational CPS prototype with in a 3 to 5 year deadline.



Founded 1986 & Incorporated 1990
 Greetings From:
 Admiral, Rick R. Dobson, Jr.
 Chairman & CEO & Founder
 International Space Agency, ISA

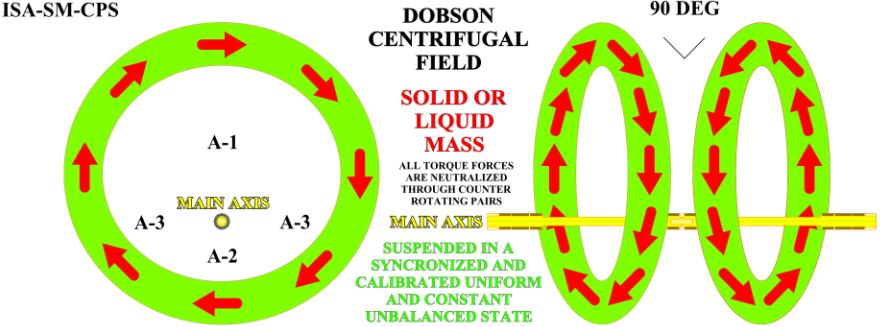

SOLID OR LIQUID MASS SUSPENDED IN A GYROSCOPIC CENTRIFUGAL FIELD MANIPULATED AROUND A CENTRAL ROTATIONAL AXIS IN A SYNCHRONIZED AND CALIBRATED OUT OF BALANCE CONFIGURATION WHICH ATTAINS A (A-1) CONSTANT "POSITIVE" OUT OF BALANCE ARCH FROM 89 TO 271 DEG (A-2) CONSTANT "NEGATIVE" OUT OF BALANCE ARCH FROM 91 TO 269 DEG (A-3) CONSTANT "NEUTRAL" BALANCED STATE BETWEEN 90 AND 270 DEG THIS CAN BE ACHIEVED EITHER BY MAGNETIC OR MECHANICAL MEANS
 COPYRIGHT & TRADEMARK & PATENT PENDING - 1986 TO 2013 - ALL RIGHTS RESERVED

Admiral, Rick R. Dobson, Jr., Founder of the International Space Agency, Is The Inventor Of The Dobson Centrifugal Field Theory, the Solid Mass Centrifugal Propulsion System, and the Liquid Metal Centrifugal Propulsion System. Started Solid Mass In 1982 Phase 1 And In 1986 Phase 3 And Finished Phase 3 In 1986 And Final Solid Mass Centrifugal Propulsion System Prototype was Finished In 1988. There is a 3D computer graphic simulation of this prototype technology that can be provided on specific request. Since 1988 classified work on the Liquid Metal Centrifugal Propulsion System has continued, but due to complexity of its Magnetic & Liquid Metal Components, a Prototype outside industry is not possible.

The Only Difference Between The Solid Mass Centrifugal Propulsion System And The Liquid Metal Centrifugal Propulsion System Is That Liquid Metal Centrifugal Propulsion System Manipulates The Liquid Metal In A Spinning Drum And The Liquid Metal Suspended In The Centrifugal Field Is Manipulated 90 Degrees Off Its Main Rotational Axis By Magnetic Forces and Manipulation. This Is Follow Up To The German Bell Technology Done By Germany In WWII.

This Propulsion System Carries Its Reaction Mass With It And Does Not Need To Interact With Mass Outside The Propulsion System. The System Is Nearly Silent When In Operation. It Provides Thrust Many Time More Than Chemical Rocket Thrust. The System Needs A Small Nuclear Reactor To Power Its Electric Drive System, and Can Operate Land & Sea & Air & Space

The 8 Main Rotor Arms Have 2 Mass Disks At The End Of Each Arm. The Mass Disks Rotate In A 1:1 Ratio With Each Other. The Gyroscopic Disks Use A Rotating Mass In One Sector Of The Disk. These Disks Rotate Counterclockwise To Each Other To Dampen Vibrations And To Balance Torque Forces.

The Mass Disks Are Hard Linked By Gear Drive To The Rotation Of The Main Rotor Assembly.. As The Mass Disks Rotate In A 1:1 Ratio With The Main Rotor Assembly, The Mass On The Mass Disks Are Always At The 12:00 O'clock (0 Degree Position) As Its Rotor Arm Is Also At The 12:00 O'clock (0 Degree Position).

So With All Mass Disks And Main Rotor Assembly (8 Rotor Arms With Each Rotor Arm With 2 Counter Rotating Mass Disks) All Locked In A Geared 1:1 Rotational Ratio, The Mass Of The Fulcrum Of The Rotor Arm (As Well As The 2 Associated Counter Rotating Mass Disks Mass Fulcrums) At The 12:00 O'clock Position (0 Degree Position) Will Always Be The Greatest Distance From The Main Rotor Assembly Axis And Exerting The Greatest Centrifugal Force (Off Balance Projection Of Gyroscopic Energy or Reaction Force/Thrust).

So With All Mass Disks And Main Rotor Assembly (8 Rotor Arms With Each Rotor Arm With 2 Counter Rotating Mass Disks) All Locked In A Geared 1:1 Rotational Ratio, The Mass Of The Fulcrum Of The Rotor Arm (As Well As The 2 Associated Counter Rotating Mass Disks Mass Fulcrums) At The 6:00 O'clock Position (180 Degree Position) Will Always Be The Least Distance From The Main Rotor Assembly Axis And Exerting The Least Centrifugal Force (Off Balance Projection Of Gyroscopic Energy or Reaction Force/Thrust).

The Mass Disks Mass Fulcrums And Corresponding Rotor Arm Mass Fulcrum Will Always Be Positive (Greater Gyroscopic Centrifugal Reaction Force/Trust) From The Top Rotational Arch Of The Main Rotor Arms Around The Main Rotor Assembly Main Rotational Axis From The 9:00 O'clock Position (270 Degree Position) To The 3:00 O'clock Position (90 Degree Position).

The Mass Disks Mass Fulcrums And Corresponding Rotor Arm Mass Fulcrum Will Always Be Reduced (Least Gyroscopic Centrifugal Reaction Force/Trust) From The Bottom Rotational Arch Of The Main Rotor Arms Around The Main Rotor Assembly Main Rotational Axis From The 9:00 O'clock Position (270 Degree Position) To The 3:00 O'clock Position (90 Degree Position).

This Creates A Gyroscopic Disk Of Mass Around A Central Rotational Gyroscopic Axis In Which The Mass Centrifugal Forces Are Always In An Out Of Balance (Max Positive) State In The Top 180 Degree Of Arch (Travel) Of The Mass Rotation Around The Central Gyroscopic Axis And The Mass Centrifugal Forces Are Always In An Out Of Balance (Reduced Positive) State In The Bottom 180 Degree Of Arch (Travel) Of The Mass Rotation Around The Central Gyroscopic Axis.

This Manipulation Of Mass In A Gyroscopic Field Around A Central Rotational Axis Creates A Controlled Out Of Balance Condition "Greater Force / Projection Of Gyroscopic Force/Energy / Reaction Thrust)

- 1) At Its GREATEST At The 12:00 O'clock (0 Degree Position)
- 2) CANCELED OUT (Equal/Balanced) At The 9:00 O'clock Position (270 Degree Position) And The 3:00 O'clock Position (90 Degree Position).
- 3) At Its LEAST At The 6:00 O'clock (180 Degree Position)

In a Such Controlled Out Of Balance State Of Rotational Mass In A Rotational Gyroscopic Field The Controlled Out Of Balance Rotational Mass Around A Central Axis Pulls The Out Of Balance Mass Disk (Pushes Anything Attached To The Main Rotational Axis) Towards The 12:00 O'clock Position (0 Deg), In Effect Converting Stored Mass Energy In A Gyroscopic Field Into Linear Energy (Gyroscopic Mass Reaction Force) THRUST.

This Can Be Done Through Mechanical Means Using Solid Mass

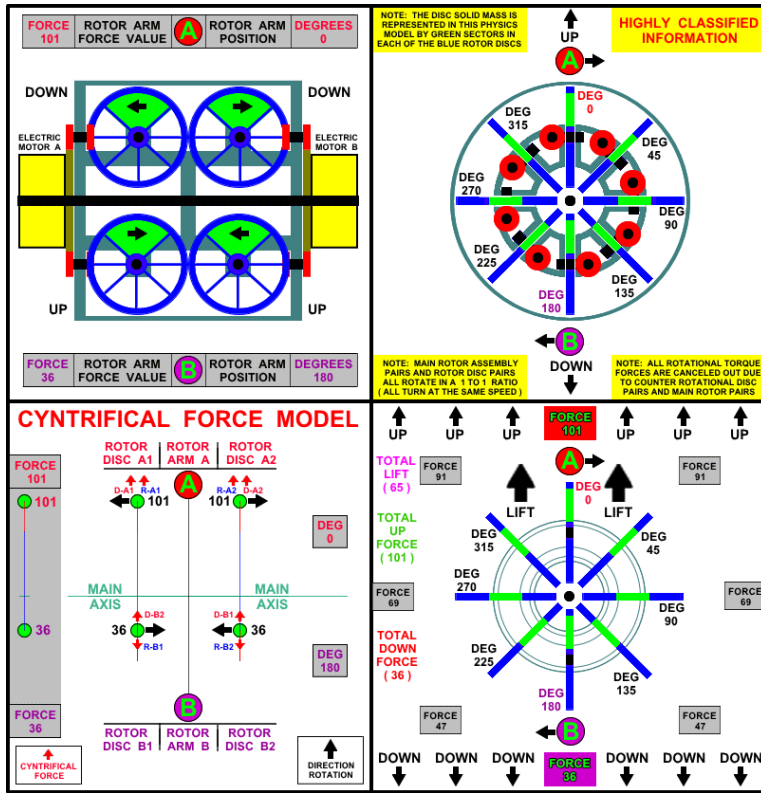

- 1) Top Left Box = Side View Of Main Rotor Assembly
Yellow = Electric Drive Motors
Green = Solid Mass
Blue = There Are 2 Counter Rotating (1:1 Ratio) Mass Disks To Each Main Rotor Arm To Cancel Rotational Torque Forces.
- 2) Top Right Box = End View Main Rotor Assembly (8 Main Rotor Arms). A/B Rotor Arms Are Frozen In Vertical Presentation And The Up And Down Orientation Changes. In This Concept Model Only One Main Rotor System Assembly Is Shown. The Operational System Would Have 2 Counter Rotating Main Rotor Assemblies To Cancel (ALL) Rotational Torque Forces.
- 3) Bottom Left Box = Thrust/Force Calculations Model
 Note: Matches Top Right Box Orientation
- 4) Bottom Right Box = End View Main Rotor Assembly. Up And Down Orientation Is Stationary And The Main Rotor Rotation Is Presented In Actual Rotation Orientation

Or This Can Be Done Through Electromagnetic Manipulation Means Using Liquid Metal Mass

Note: It Was Done In The German WWII Top Secrete Bell Research Program

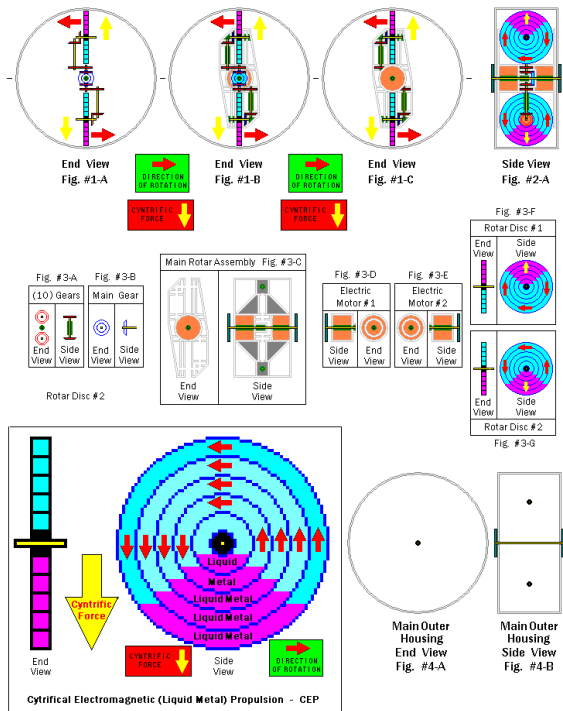

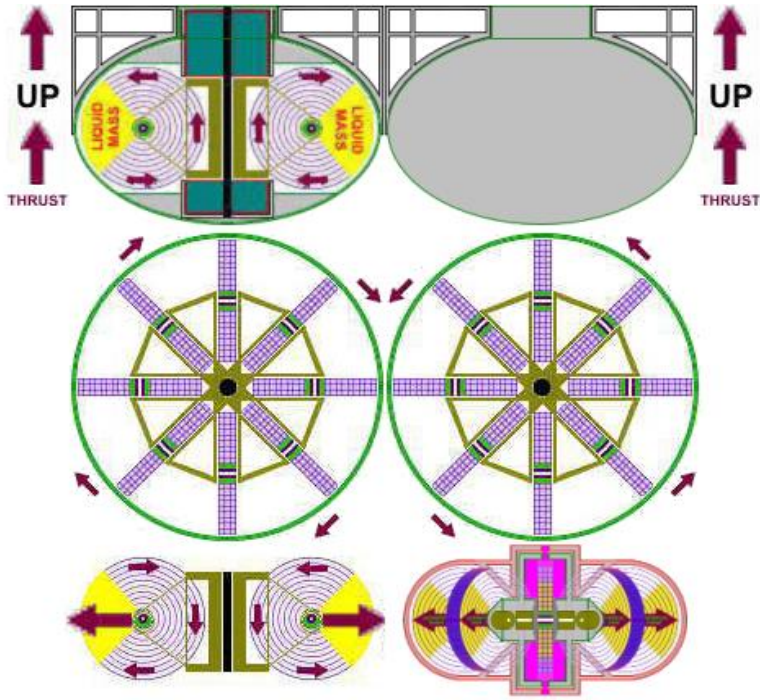

Liquid Metal "Mass" Electrostatic (L.M.E.) Centrifugal Propulsion System (C.P.S.) Program

B) NOTE: PLEASE SEE LIQUID METAL"MASS" ELECTROSTATIC (L.M.E.) CENTRIFUGAL PROPULSION SYSTEM (C.P.S.) PROPOSAL FOR THE FULL INFORMATION & SYSTEM PROPOSAL ON THIS APPLIED VARIATION OF THE ISA CPS PROPULSION SYSTEM AND CONCEPT.

SOLID MASS CENTRIFUGAL PROPULSION SYSTEM OPERATIONAL PROTOTYPE 2 DEVELOPMENT IN 2015

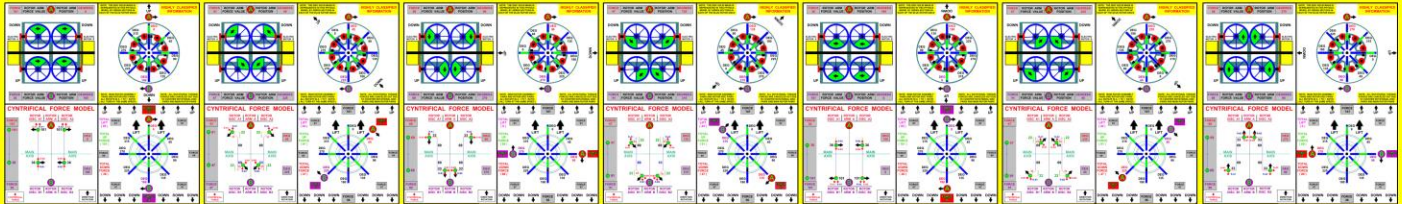
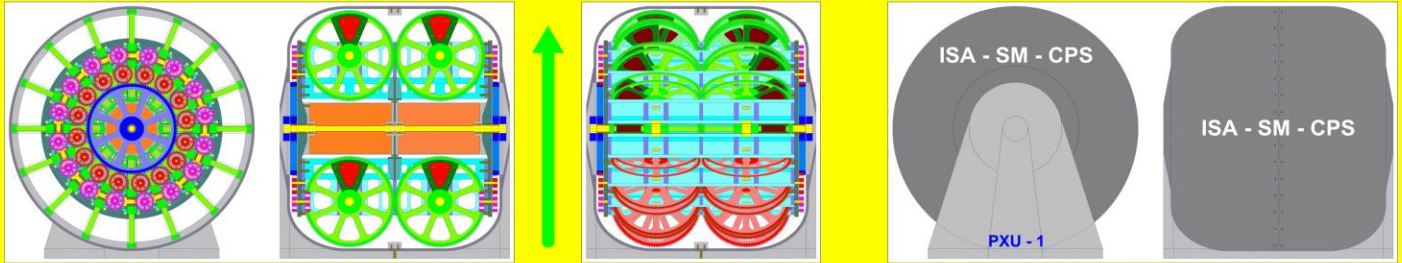

PROPERTY OF THE INTERNATIONAL SPACE AGENCY

PROJECT INRI, SOLID (LIQUID) MASS CENTRIFUGAL PROPULSION SYSTEM, LIFTER SHIPS
PATENT PENDING, TRADEMARKS, COPYRIGHTS - 1982 TO 2015 - ALL RIGHTS RESERVED

SOLID MASS CENTRIFUGAL PROPULSION SYSTEM

SYSTEM CONCEPT CREATION STARTED IN 1982

TECHNICAL RENDERINGS / DEVELOPMENT IN 1986

SYSTEM TECHNICAL / ENGINEERING WORK 1988

ISA-SM-CPS PROTOTYPE 1 RENDERINGS IN 1990

ISA-SM-CPS PROTOTYPE 1 CONSTRUCTED IN 1991

LIQUAD MASS SYSTEM UTILIZATION EXPLORED IN 1997

OPERATIONAL PROTOTYPE 2 DEVELOPMENT IN 2013



International Space Agency, I.S.A.
International Space Administration
 Founded In 1986 -&- Incorporated In 1990
 Presently Seeking International Treaty -and- Charter Status

2013 - PROPOSAL

**SOLID MASS MECHANICAL
 (S.M.M.) CENTRIFUGAL
 PROPULSION SYSTEM (C.P.S.)
 PROGRAM / OFFICE**

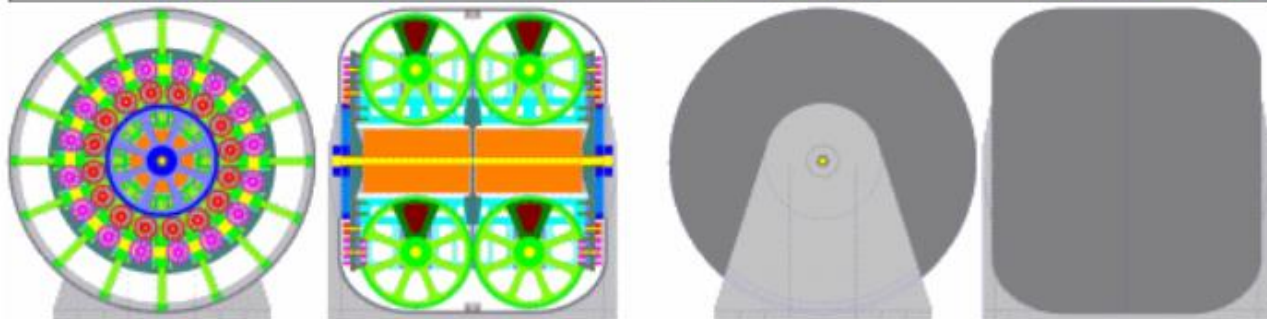
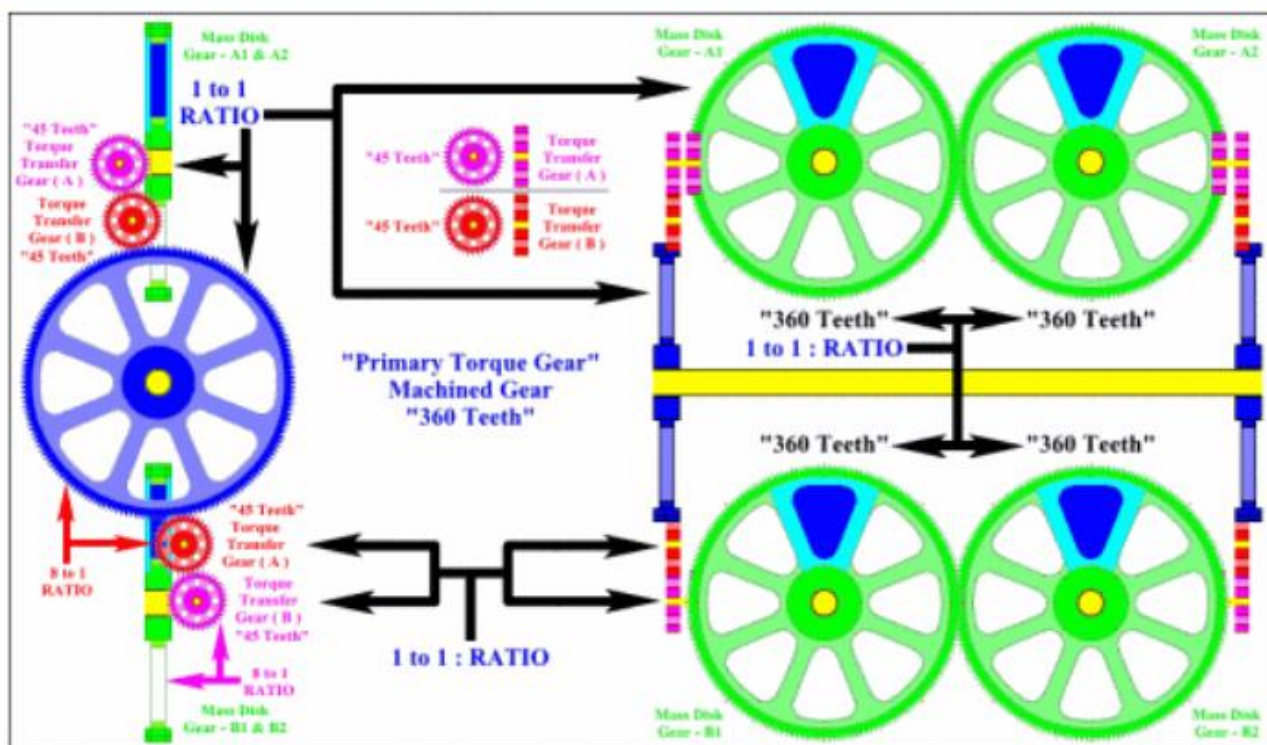

Solid Mass Mechanical (S.M.M.) Centrifugal Propulsion System (C.P.S.) Program

International Space Agency, I.S.A.: Name, Public Identity, Logo, Emblem: Are: U.S.A. Registered®: Trademark™ -&- Copyrights©, 1986-2017, All Rights Reserved
 United Space Federation, U.S.F.: Scientific -&- Aerospace/Research -&- Development / Non-Profit Corporation / Incorporated 1990 / New York State / United States

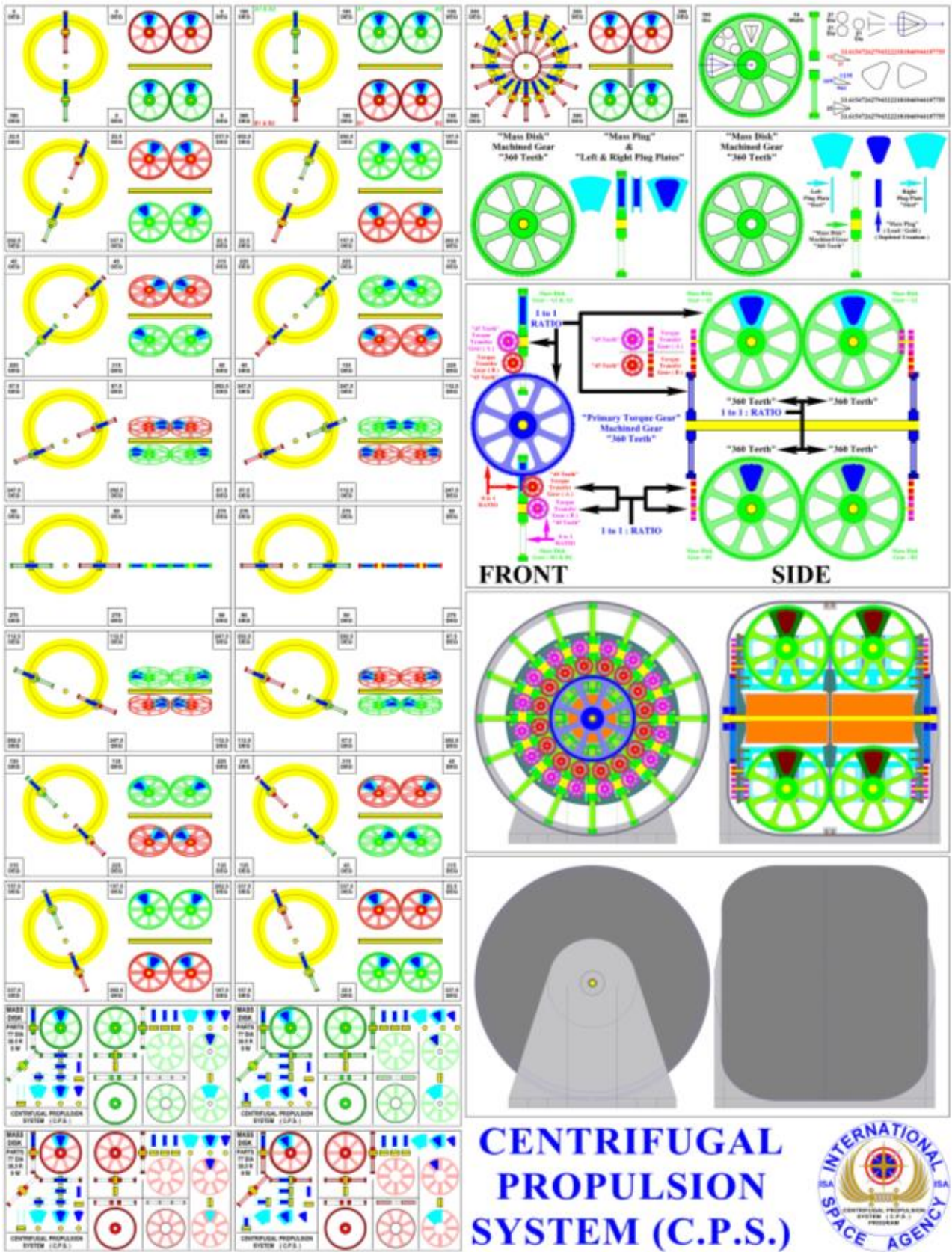

CENTRIFUGAL PROPULSION SYSTEM (C.P.S.) PROGRAM

International Space Agency
 Proprietary Information
 Trademark & Copyright Protected
 1986 to 2017. All Rights Are Reserved

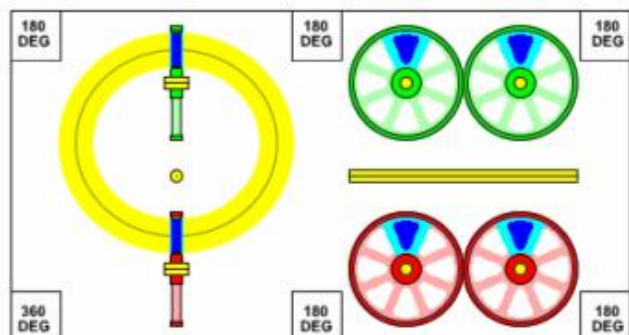
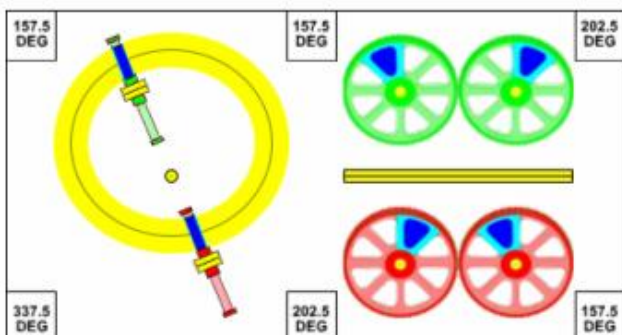
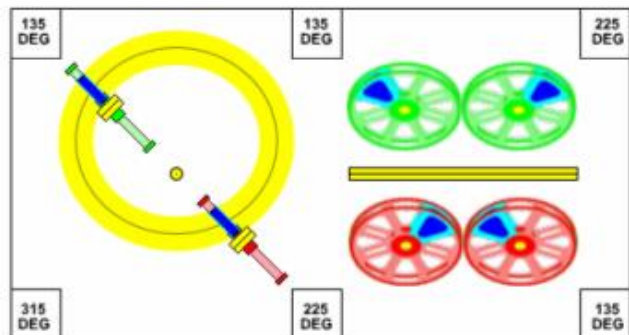
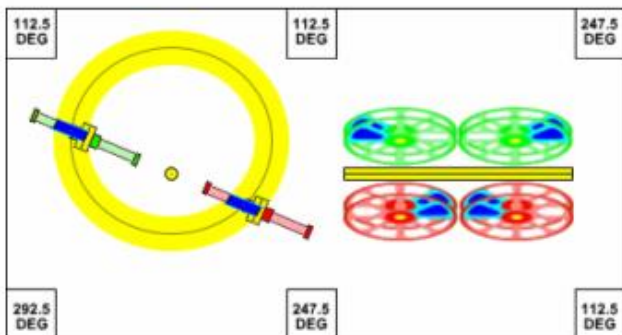
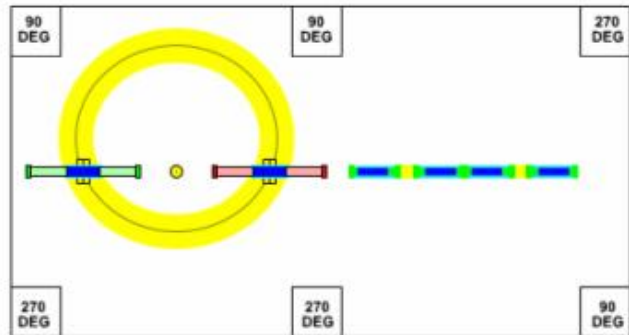
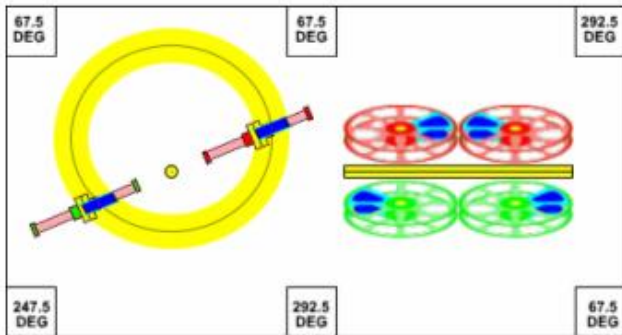
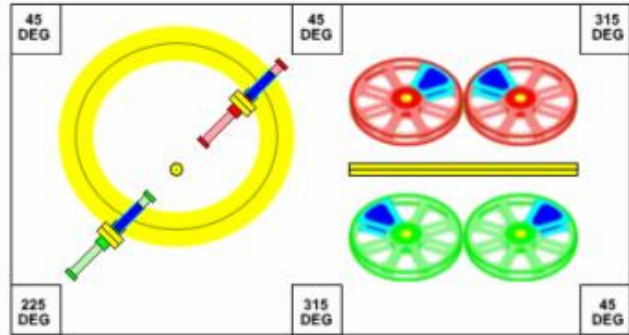
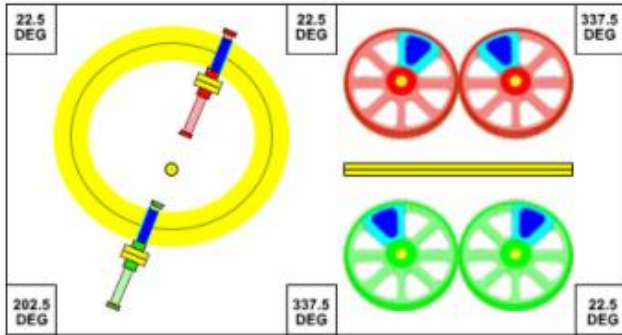
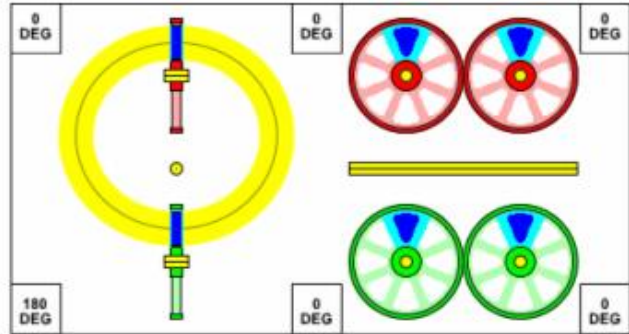

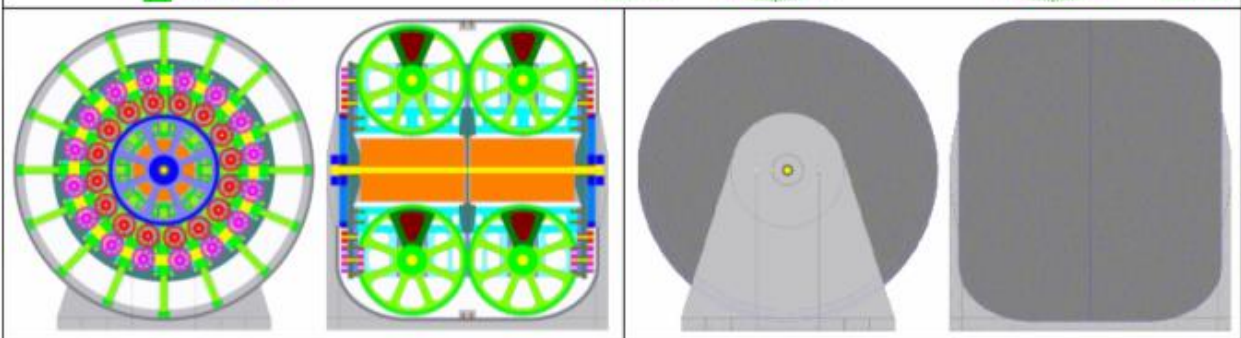
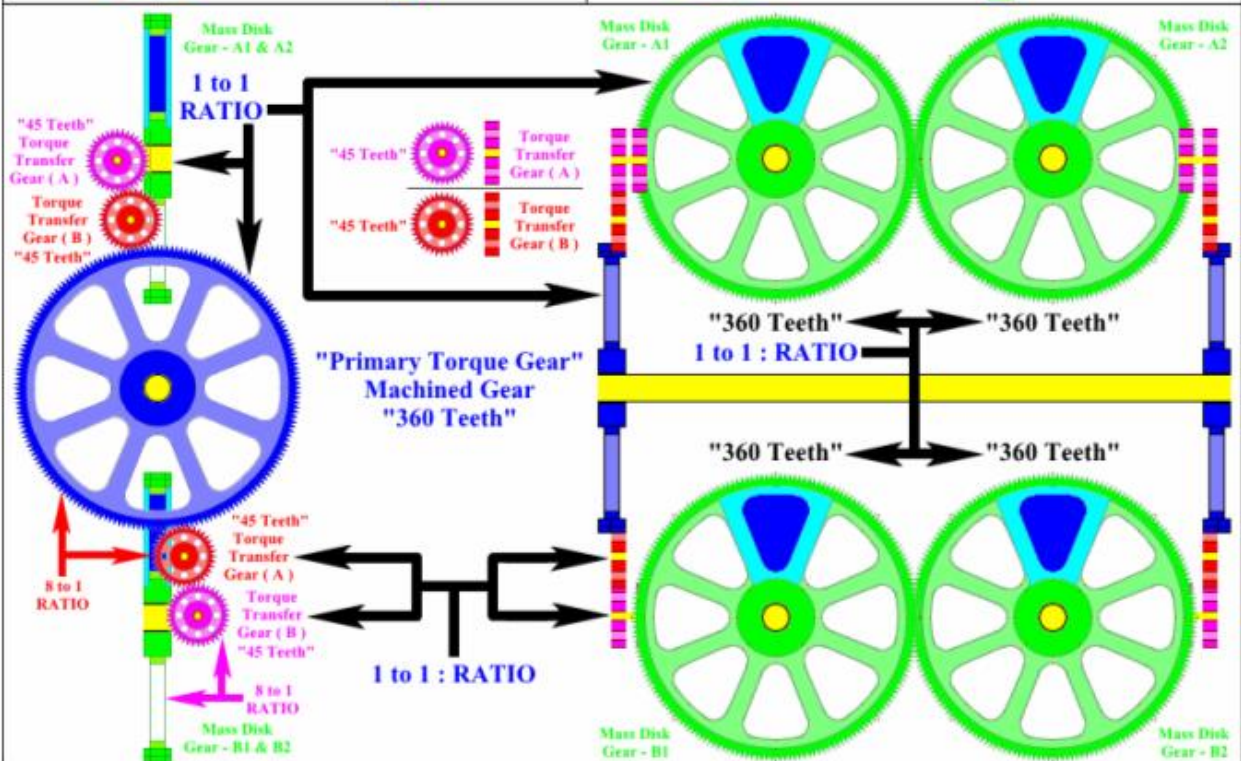
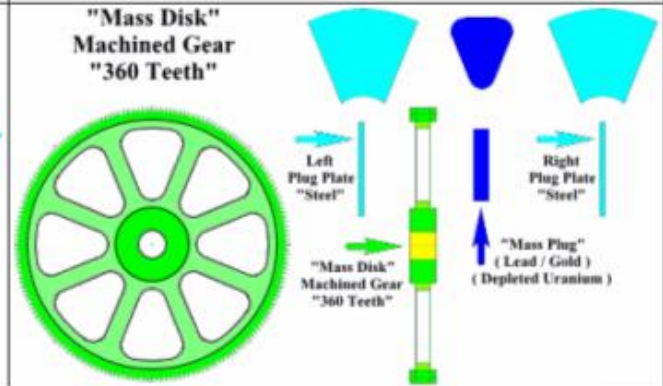
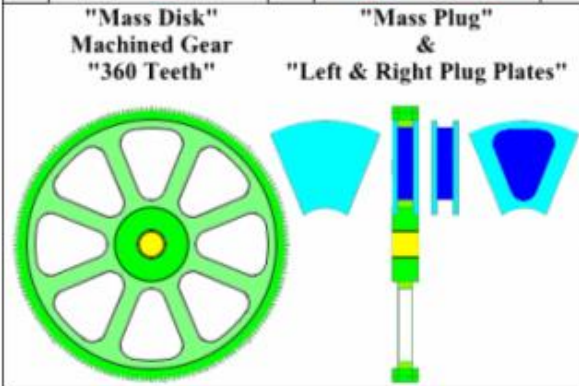
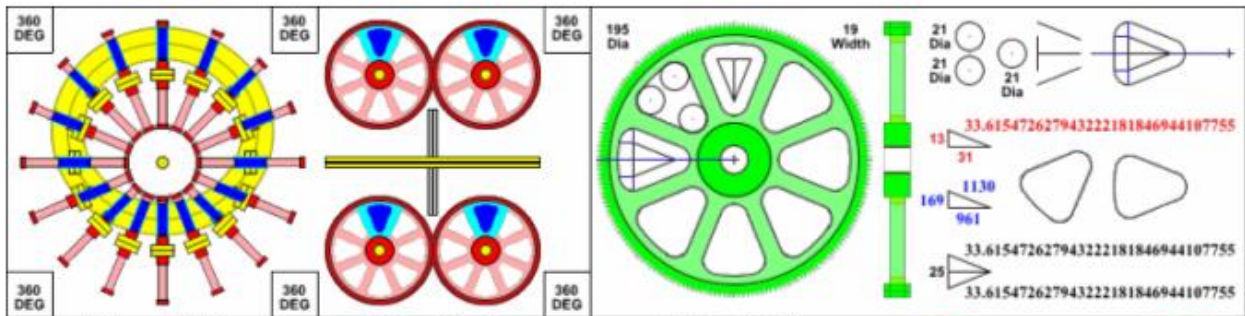

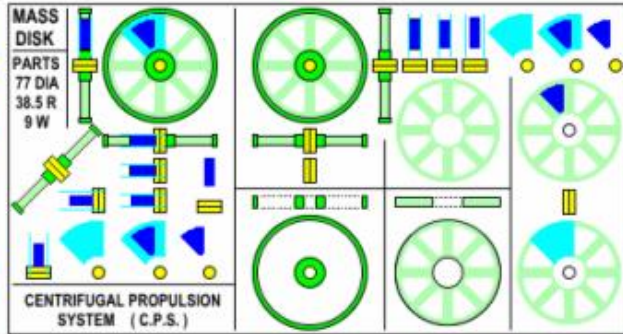
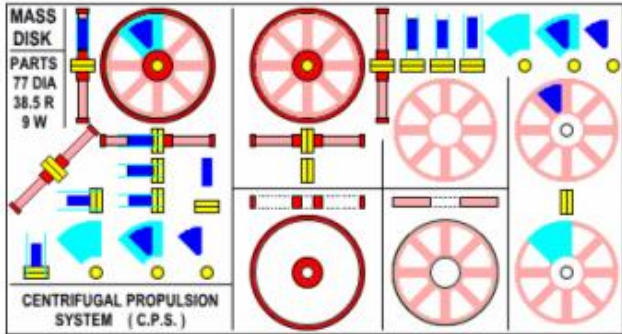
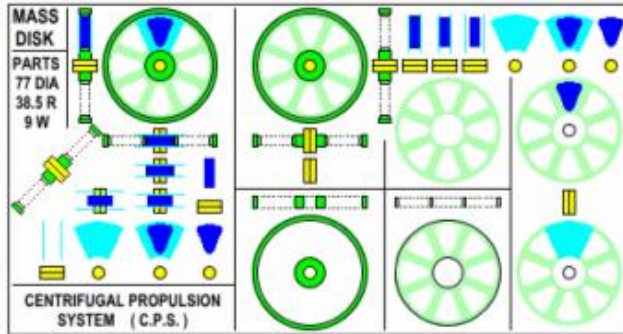
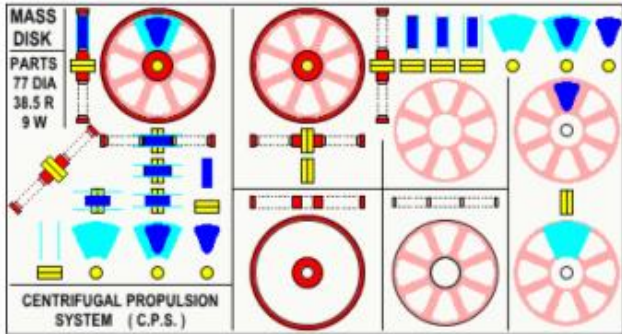
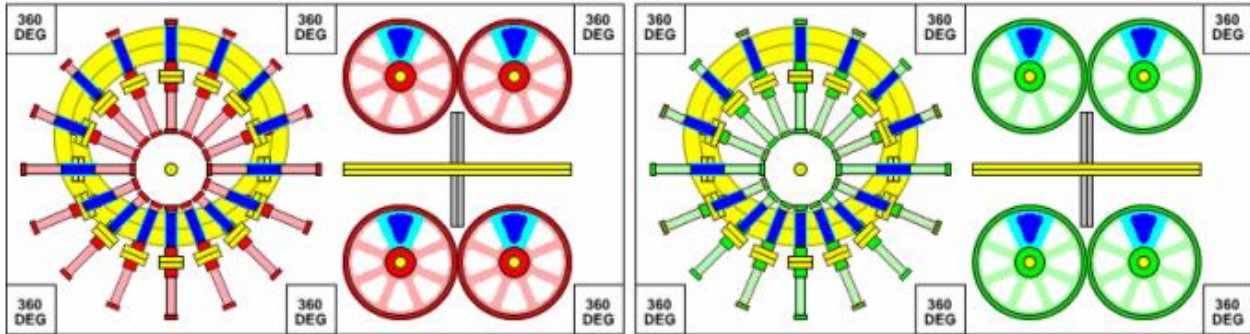
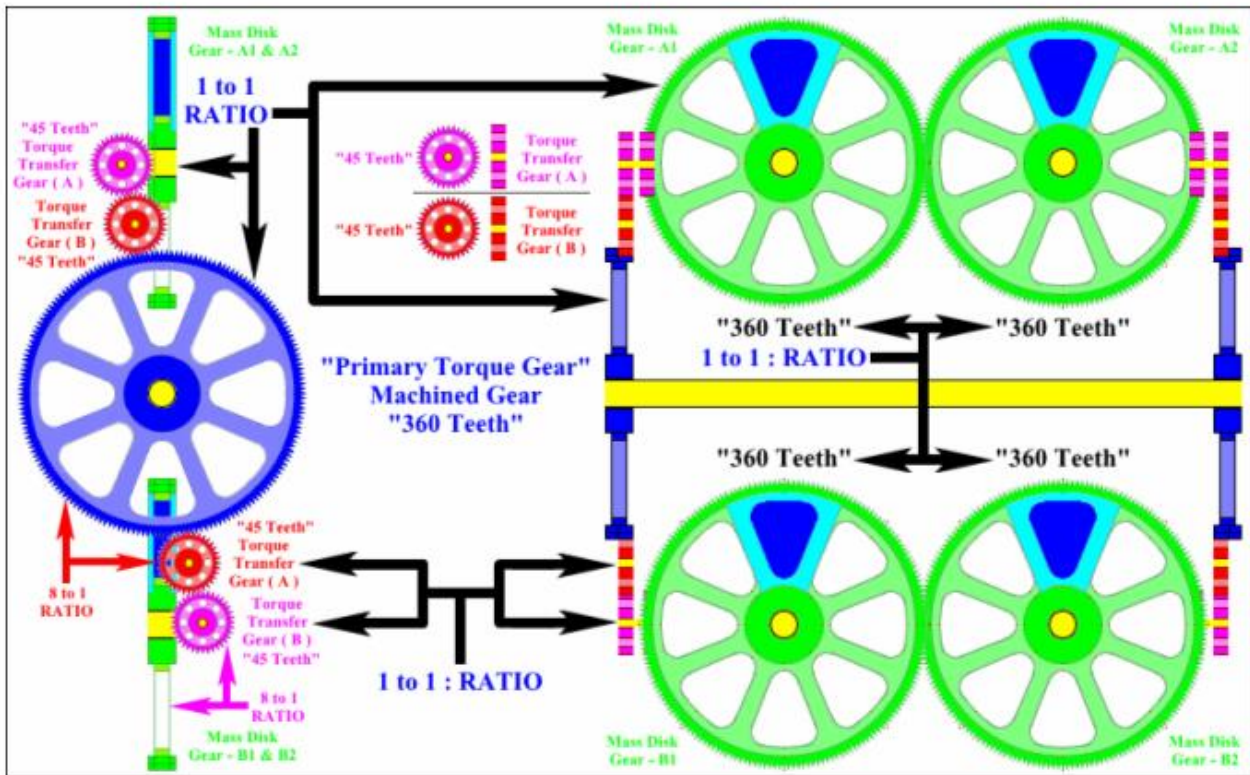

MASS DISK (GEAR) COMPONENTS AND CONFIGURATION

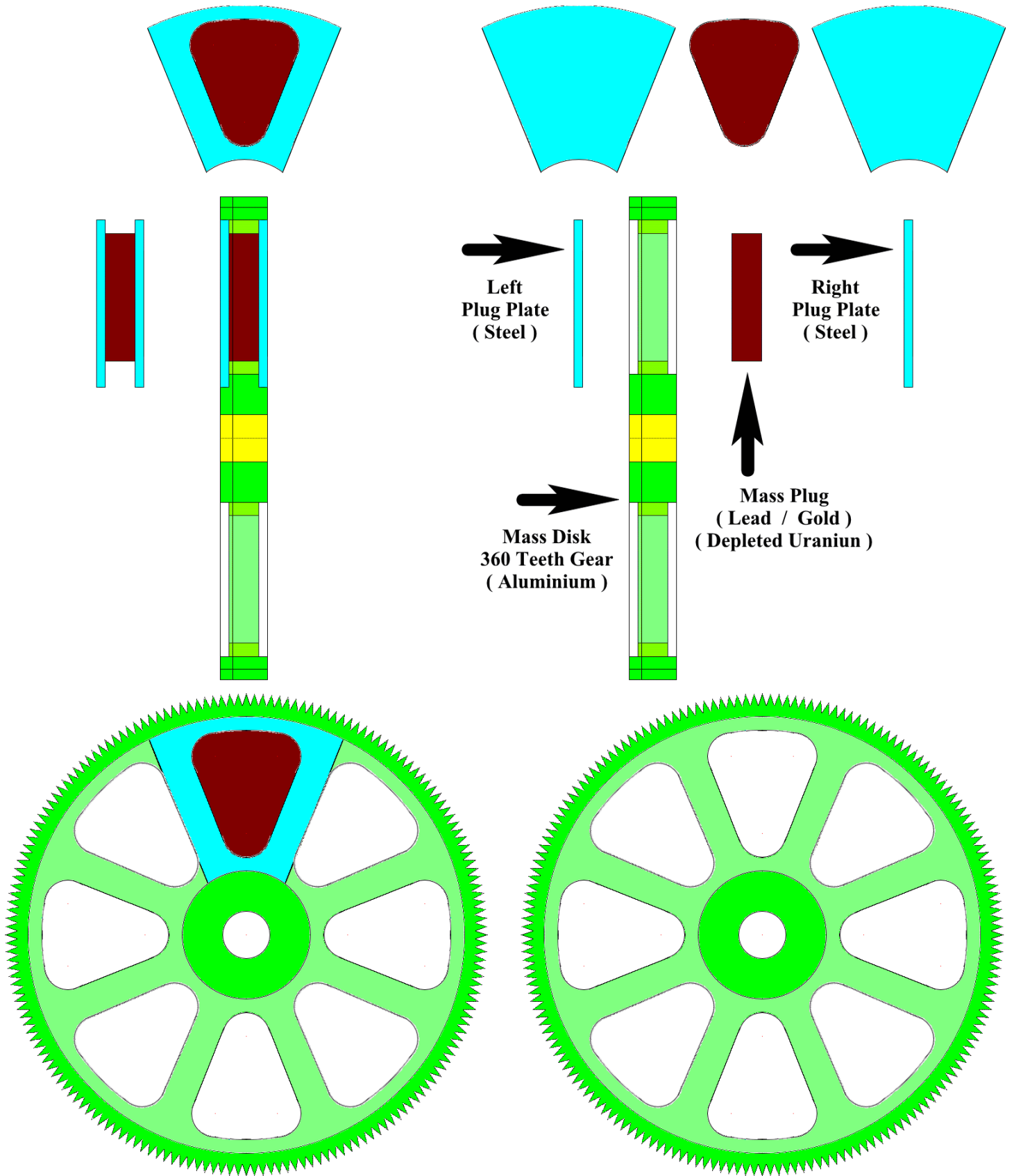

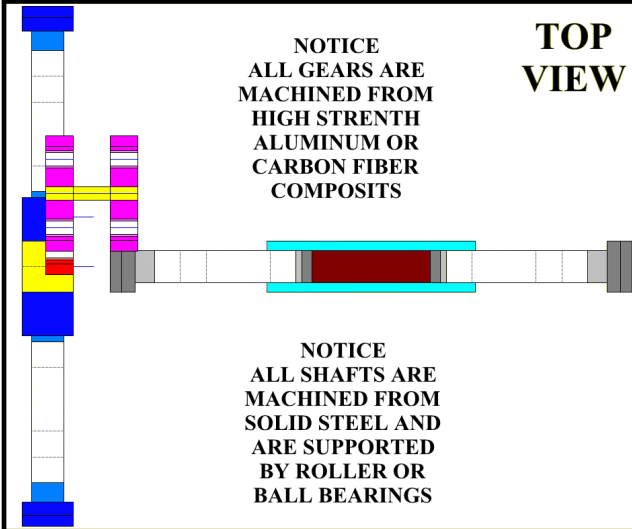
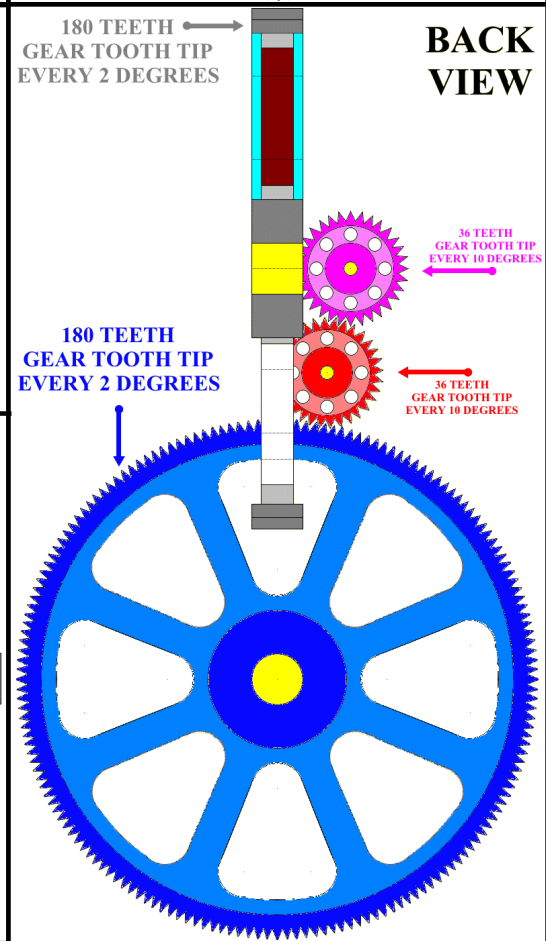
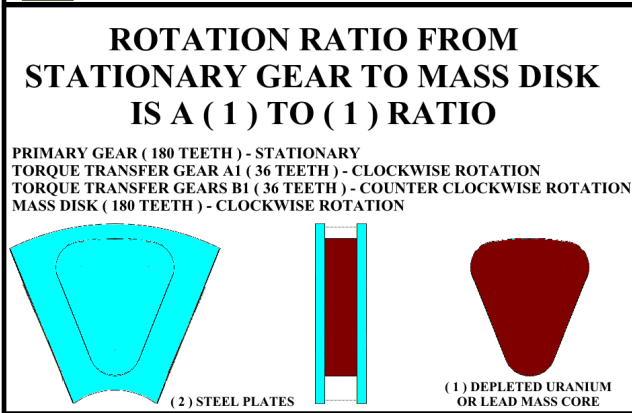
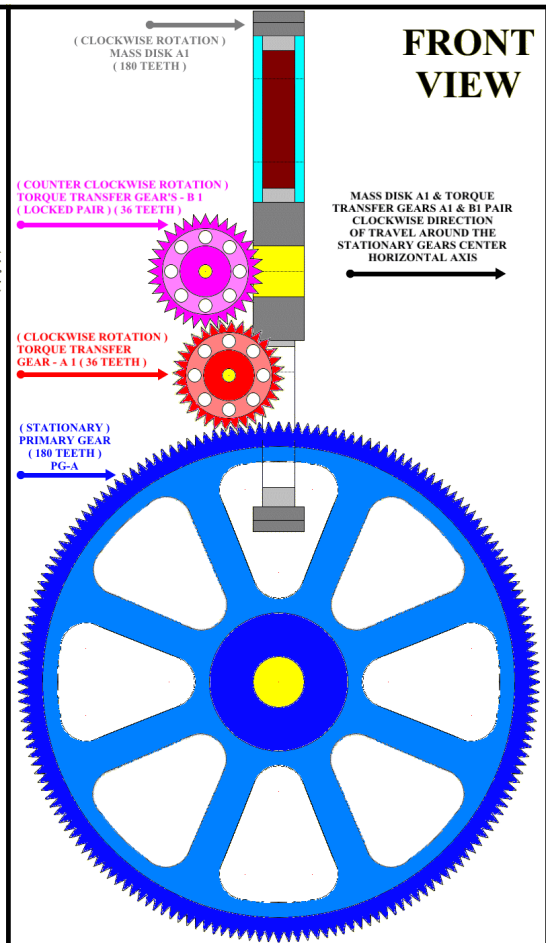
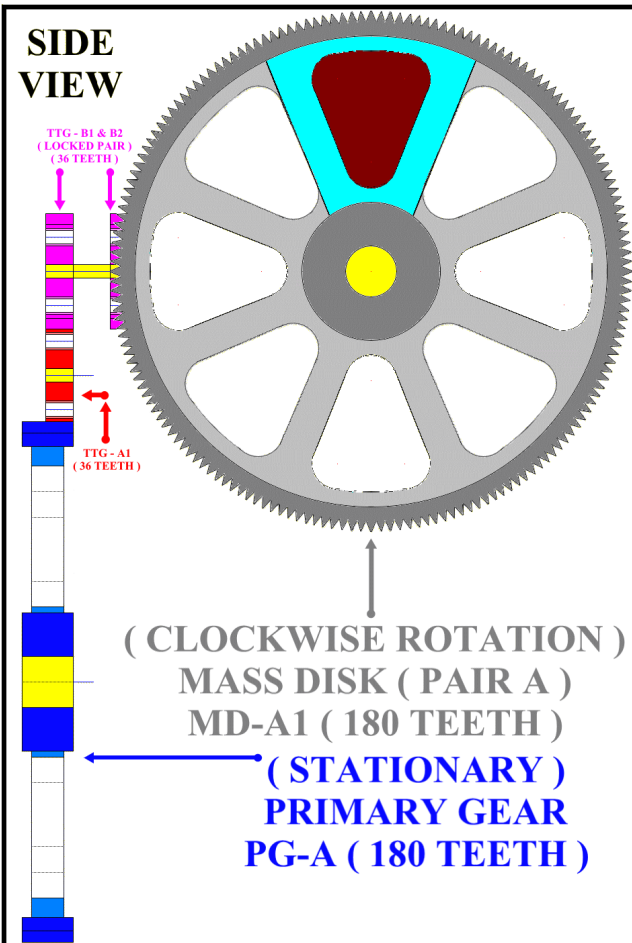

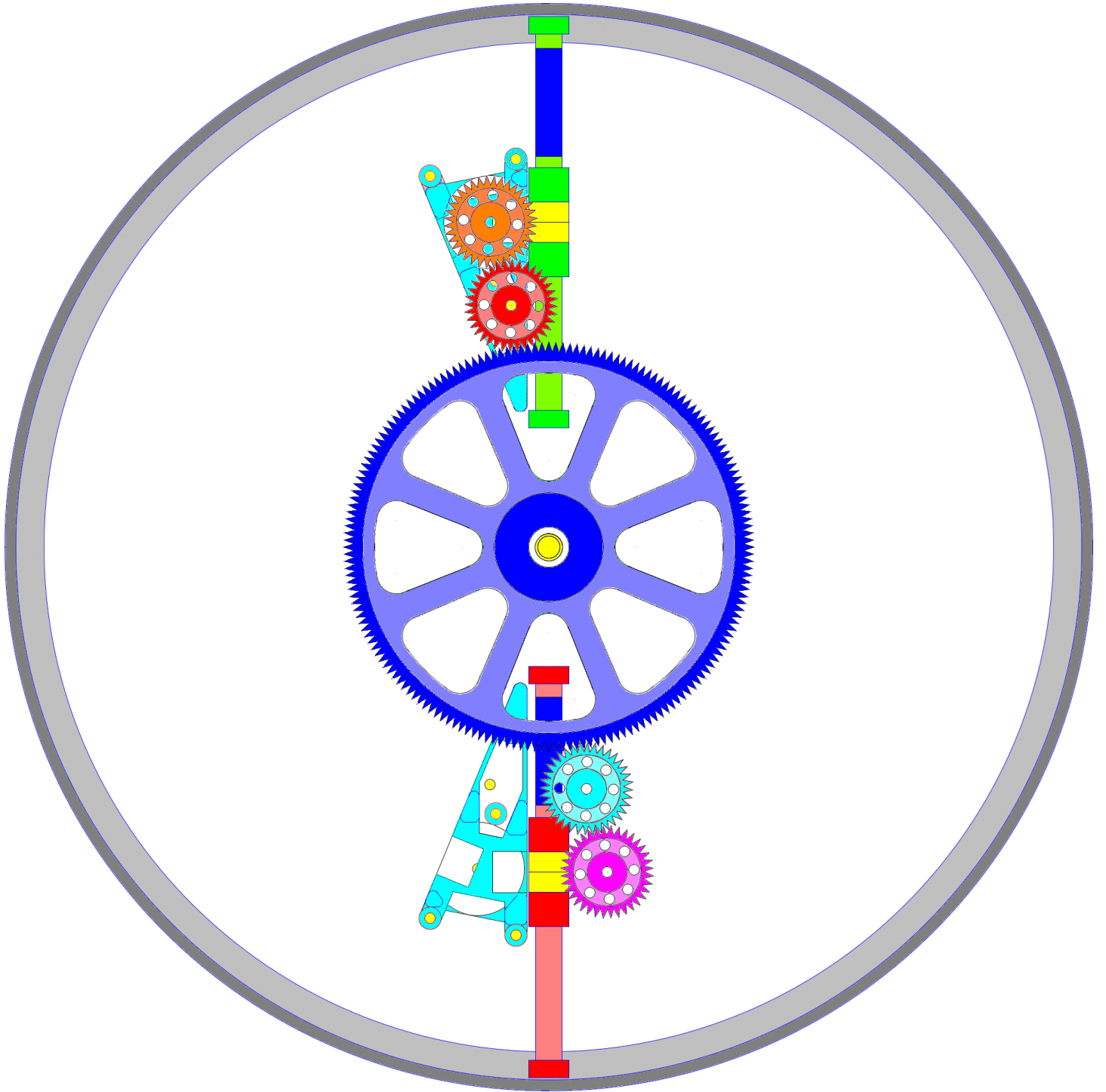

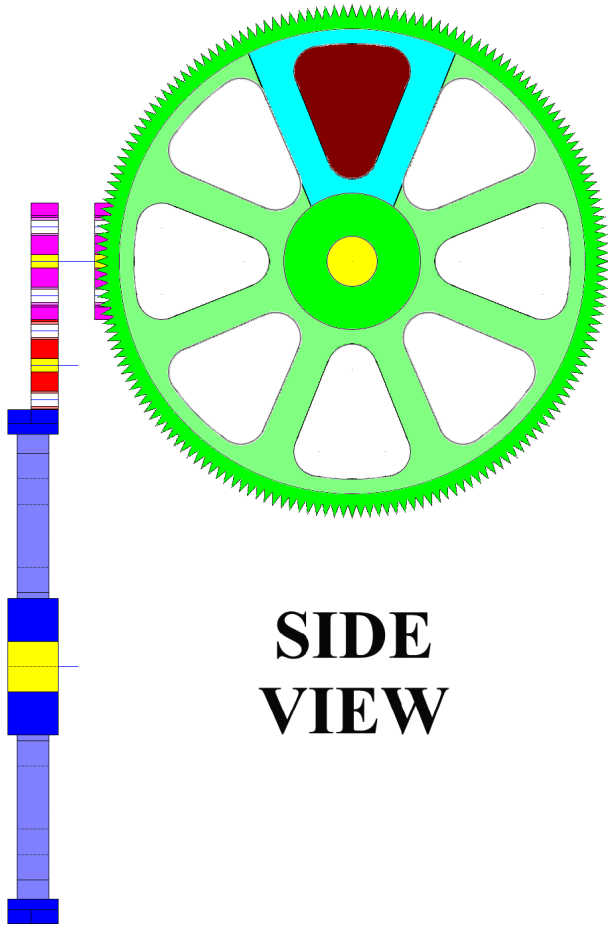

**SIDE
VIEW**

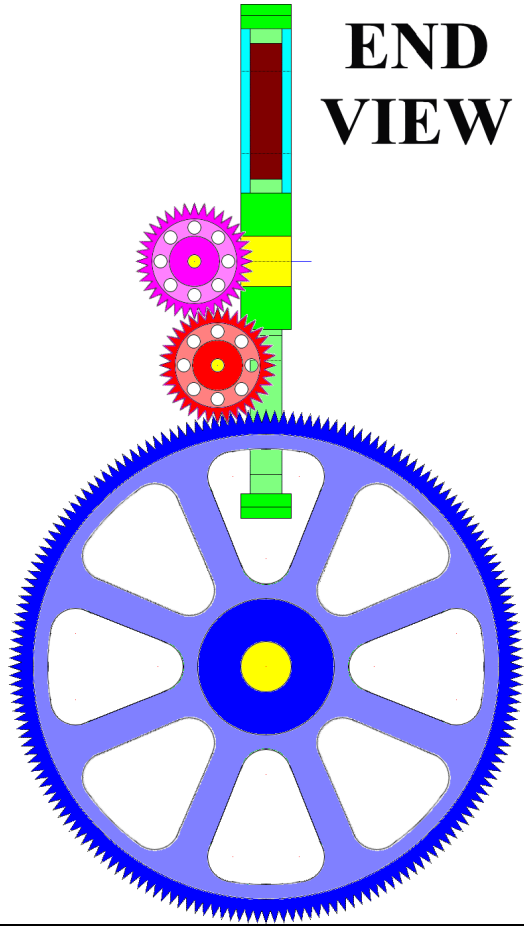

**END
VIEW**

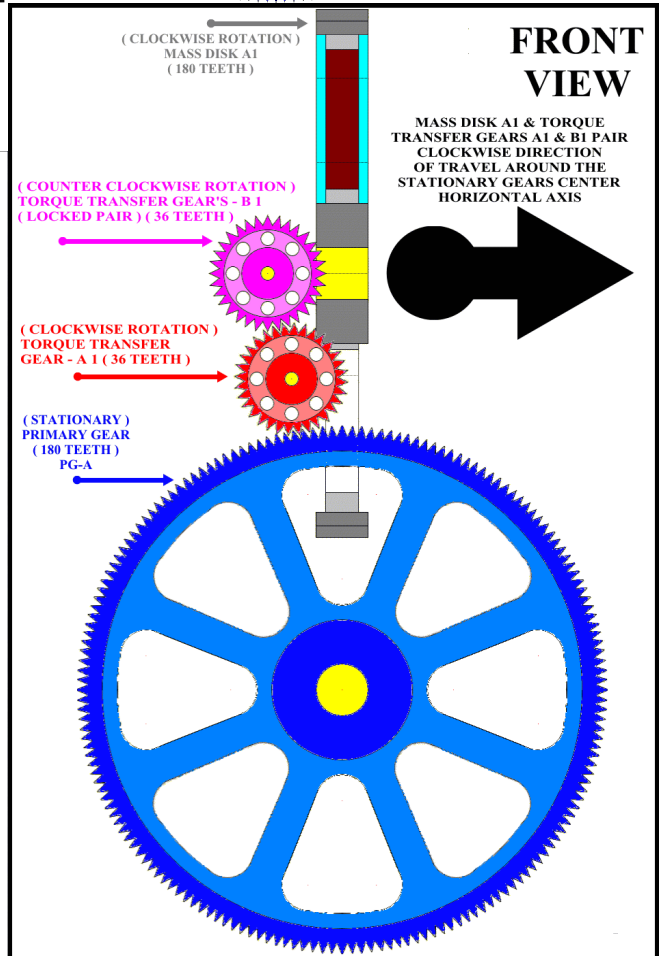
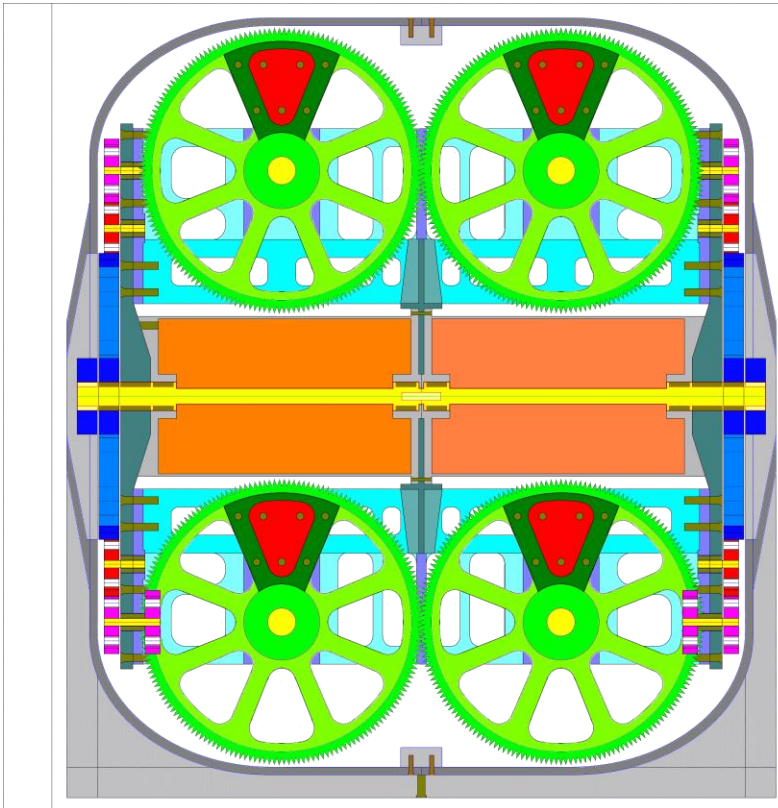

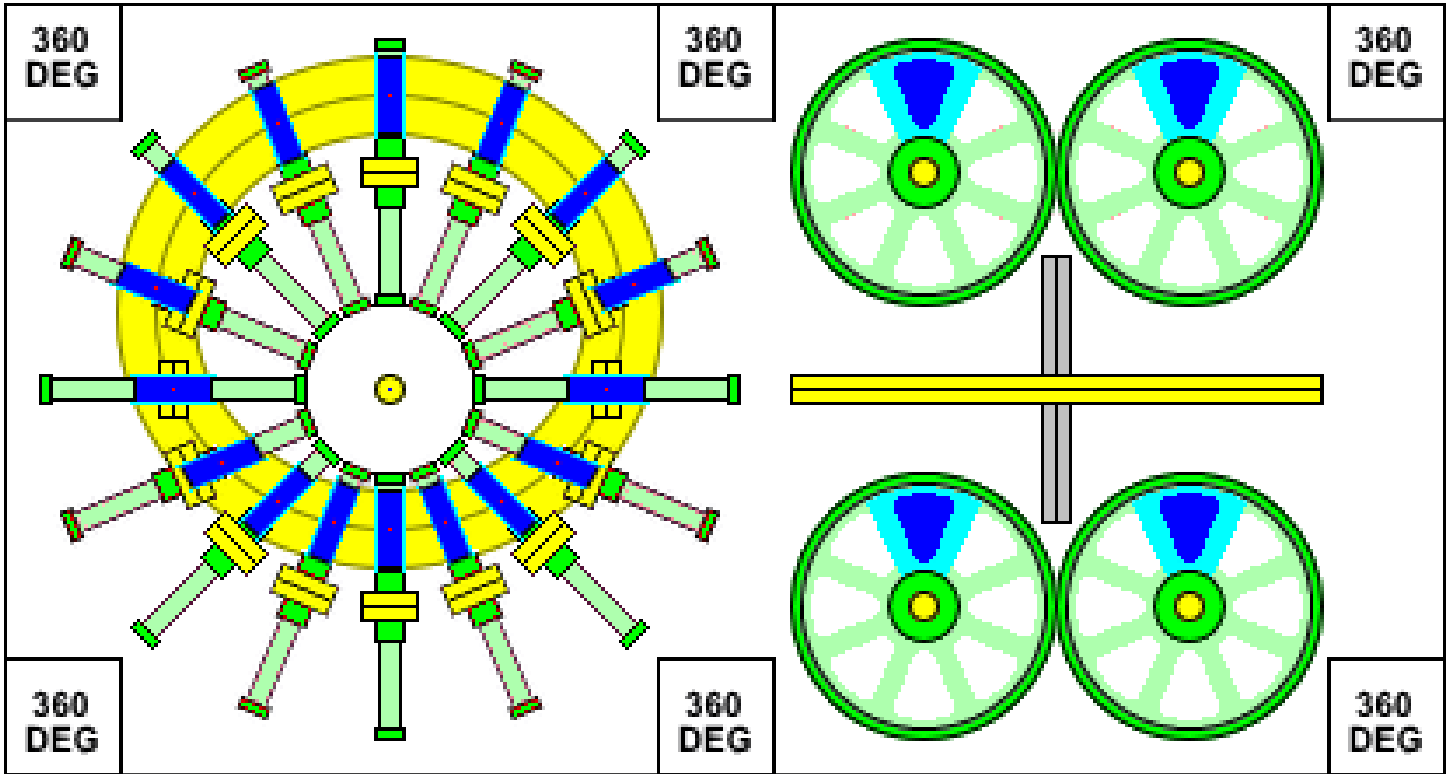
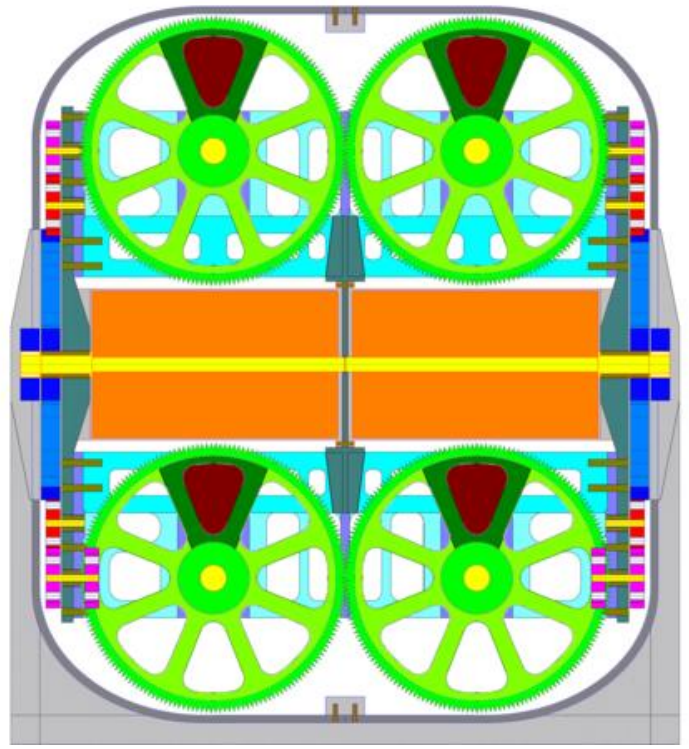
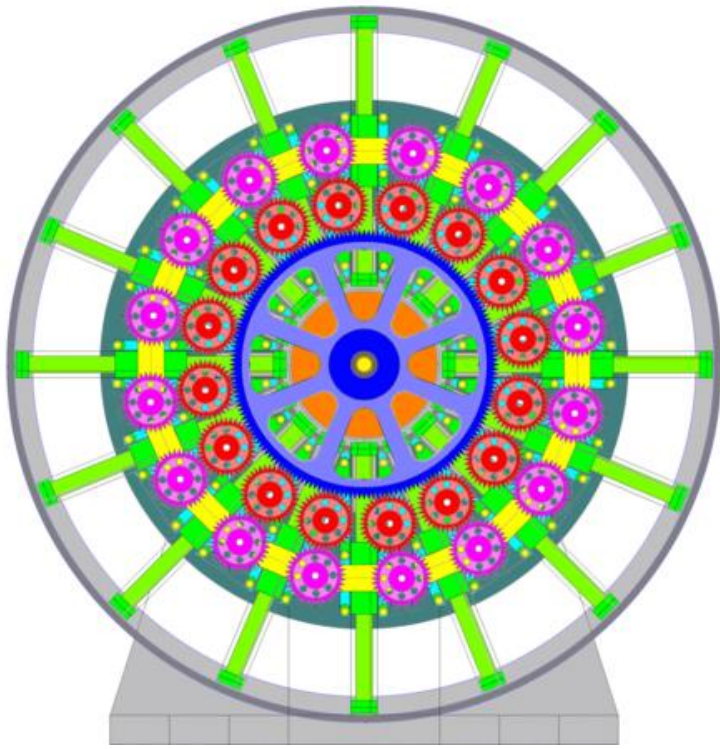

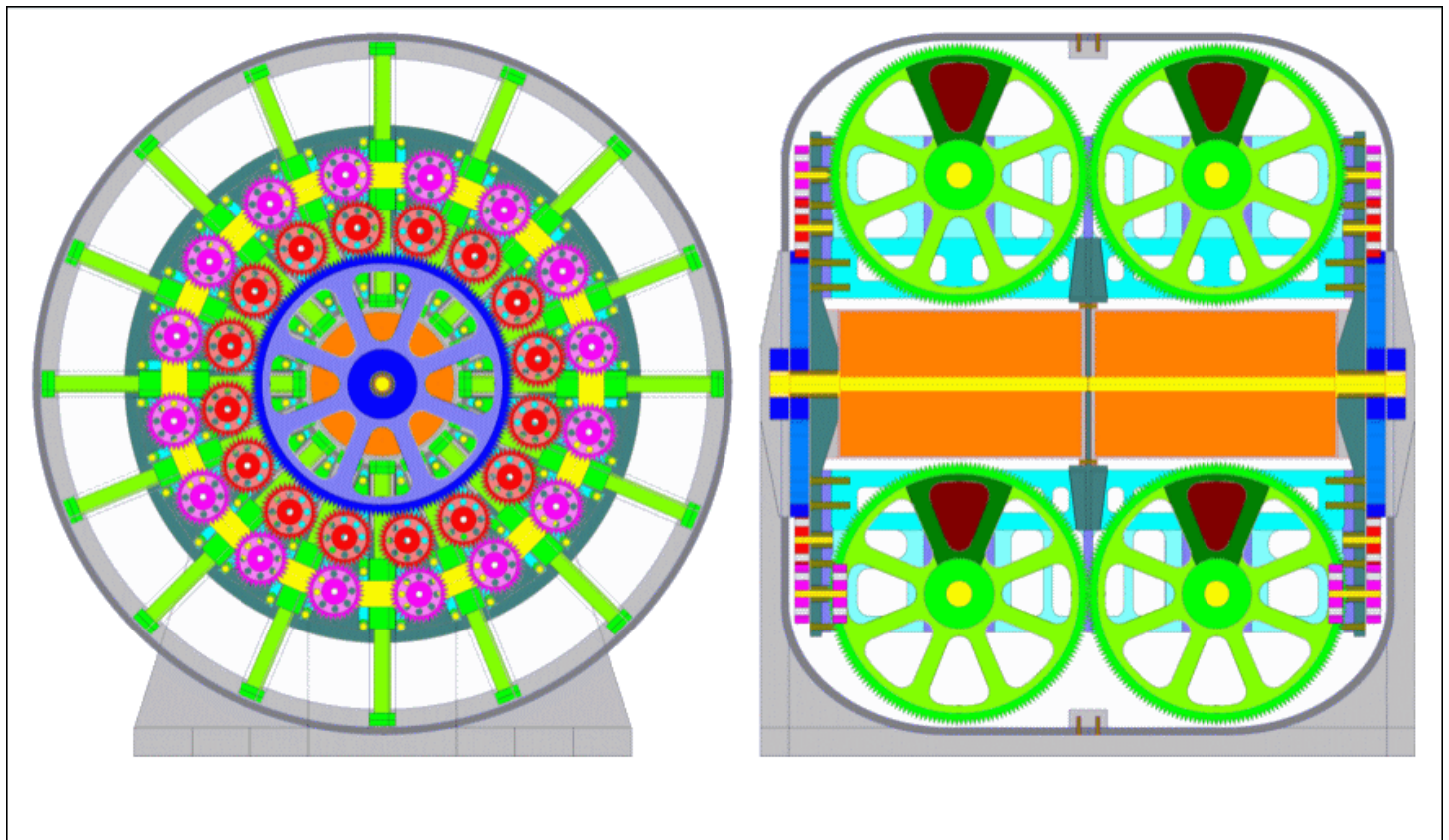
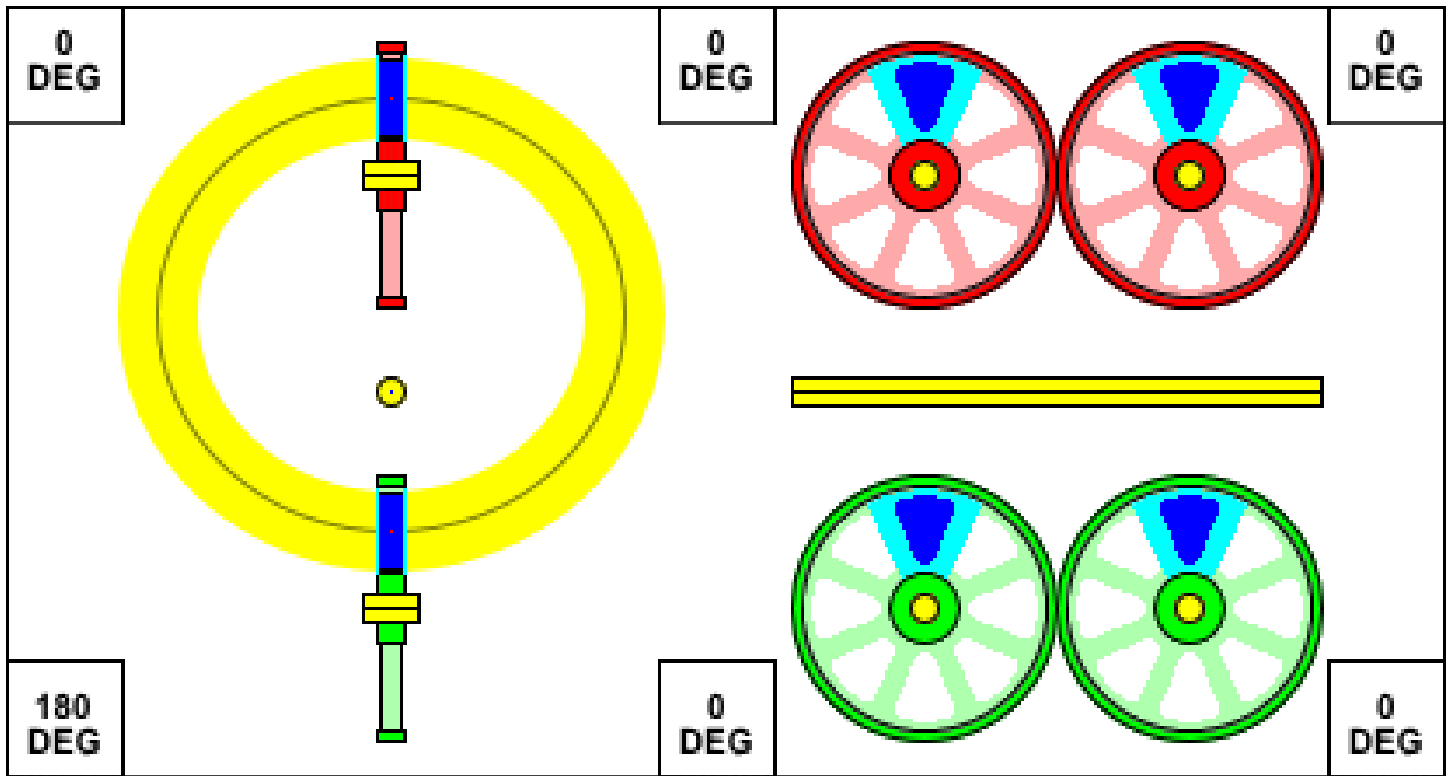

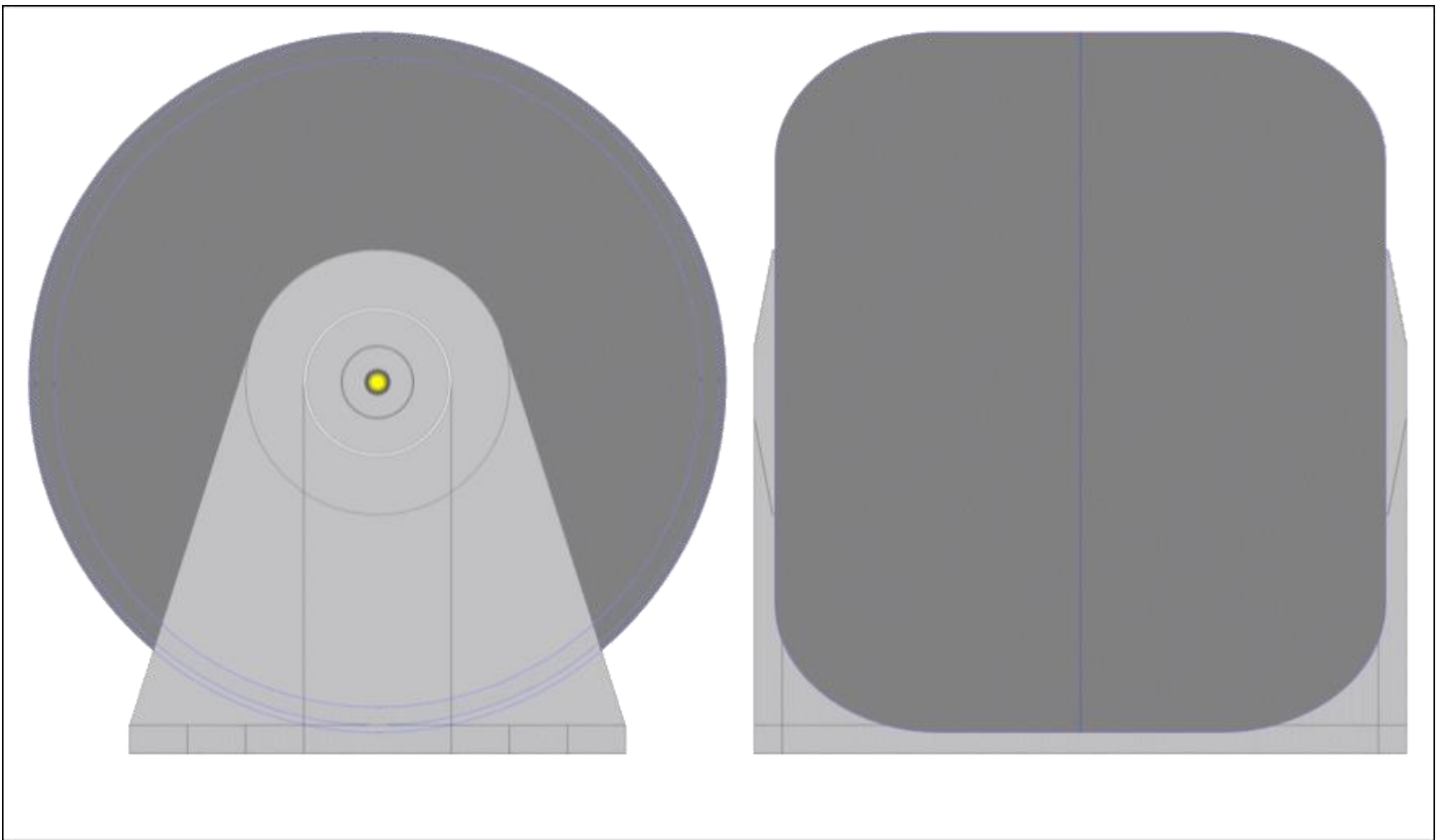
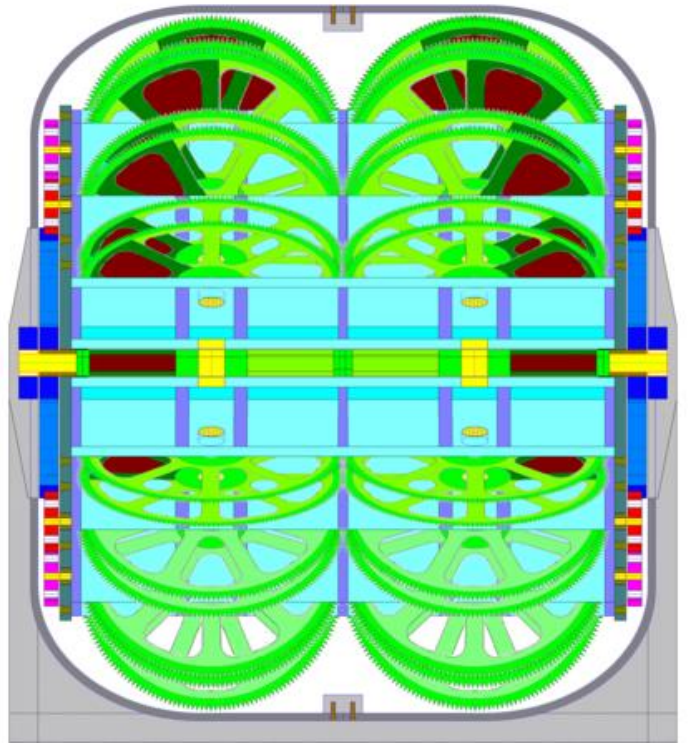
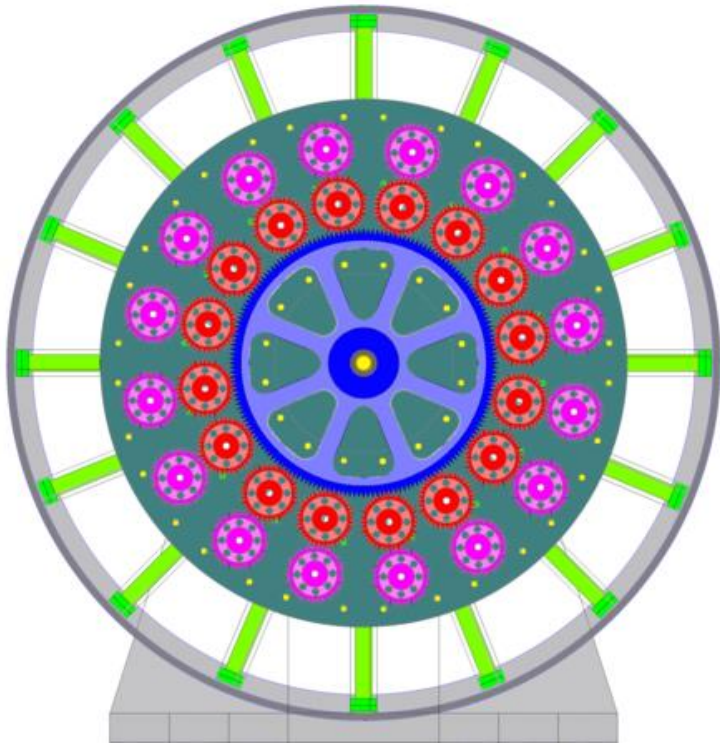

SIDE VIEW
(FROM LEFT SIDE)

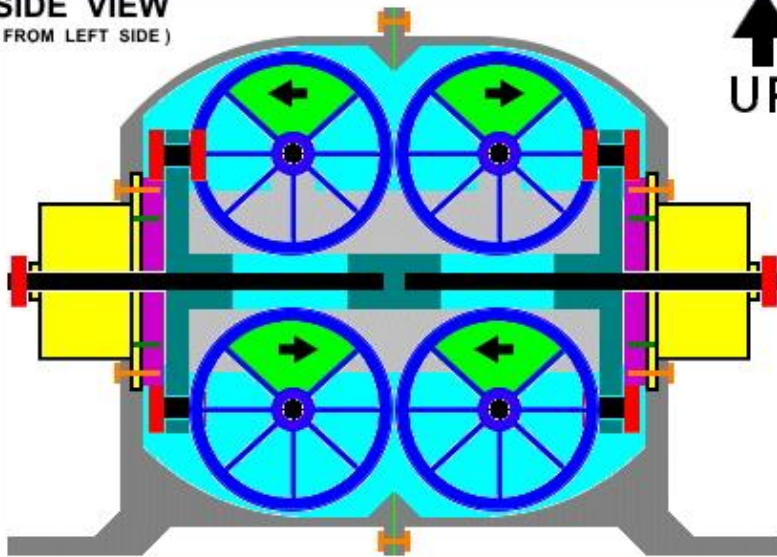

END VIEW

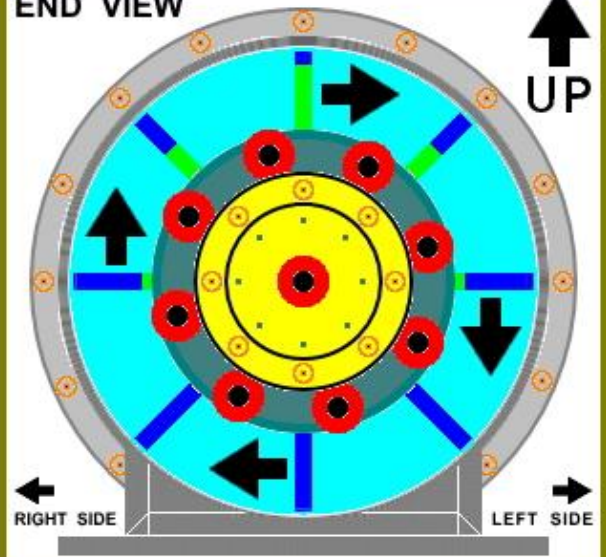

RIGHT SIDE

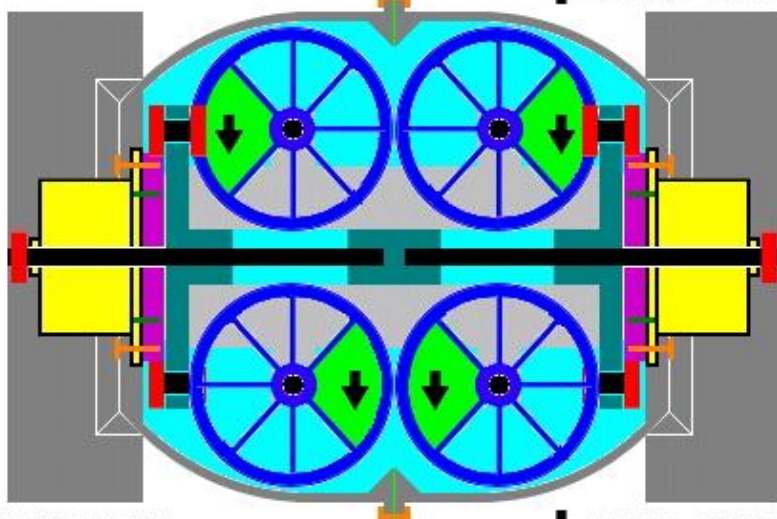

TOP VIEW

LEFT SIDE

UP **RIGHT SIDE**

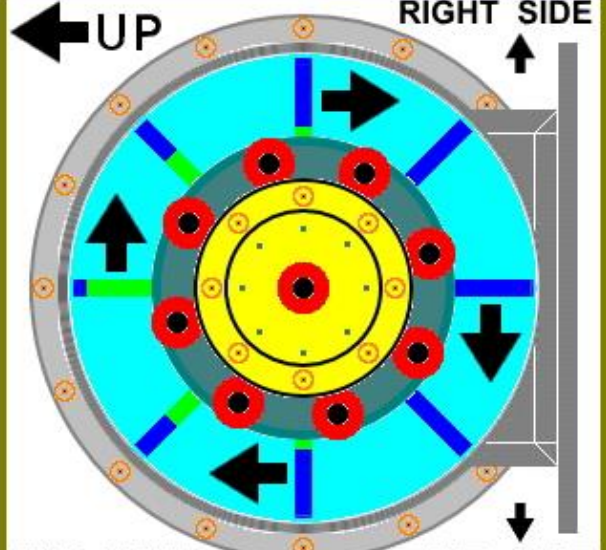

END VIEW

LEFT SIDE

SOLID MASS CYNTRIFICAL PROPULSION SYSTEM

HIGHLY CLASSIFIED -&- CONFIDENTIAL INFORMATION

NOTICE: DRAWINGS ARE: TRADEMARK (TM) -&- COPYRIGHT (C), 1986 TO 2006 , ALL RIGHTS RESERVED

NOTICE: This invention is the sole creation / invention of Mr. Rick R. Dobson, Jr., and work on this invention was started by Mr. Dobson in January 1986, and evolved to its present finished state of development in November 2006

INVENTOR / DESIGNER

Mr. Rick R. Dobson, Jr.
SSN #: 105 - 54 - 4115
DOB: 31 October 1963
SIGNATURE:

DATE:

PROFESSIONAL WITNESS

Mr. Jerald A. Schneider
SSN #:
DOB:
SIGNATURE:

DATE:

PATIENT ATTORNEY

Mr. Adam H. Jacobs
SSN #:
DOB:
SIGNATURE:

DATE:

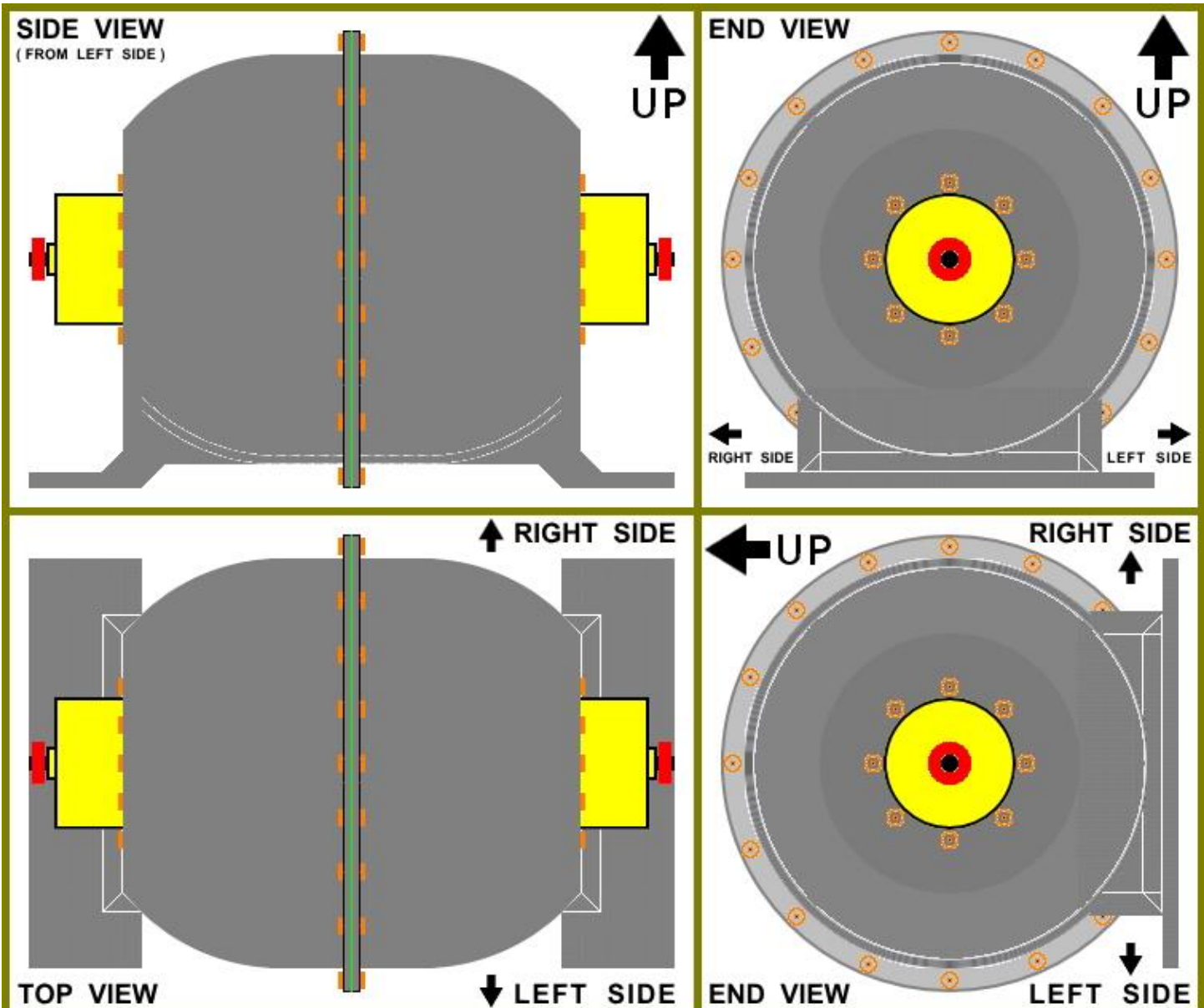

SOLID MASS CENTRIFUGAL PROPULSION SYSTEM

HIGHLY CLASSIFIED -&- CONFIDENTIAL INFORMATION

NOTICE: DRAWINGS ARE: TRADEMARK (TM) -&- COPYRIGHT (C), 1986 TO 2006 , ALL RIGHTS RESERVED

NOTICE: This invention is the sole creation / invention of Mr. Rick R. Dobson, Jr., and work on this invention was started by Mr. Dobson in January 1986, and evolved to its present finished state of development in November 2006

INVENTOR / DESIGNER
 Mr. Rick R. Dobson, Jr.
 SSN #: 105 - 54 - 4115
 DOB: 31 October 1963
SIGNATURE:

DATE:

PROFESSIONAL WITNESS
 Mr. Jerald A. Schneider
 SSN #:
 DOB:
SIGNATURE:

DATE:

PATIENT ATTORNEY
 Mr. Adam H. Jacobs
 SSN #:
 DOB:
SIGNATURE:

DATE:

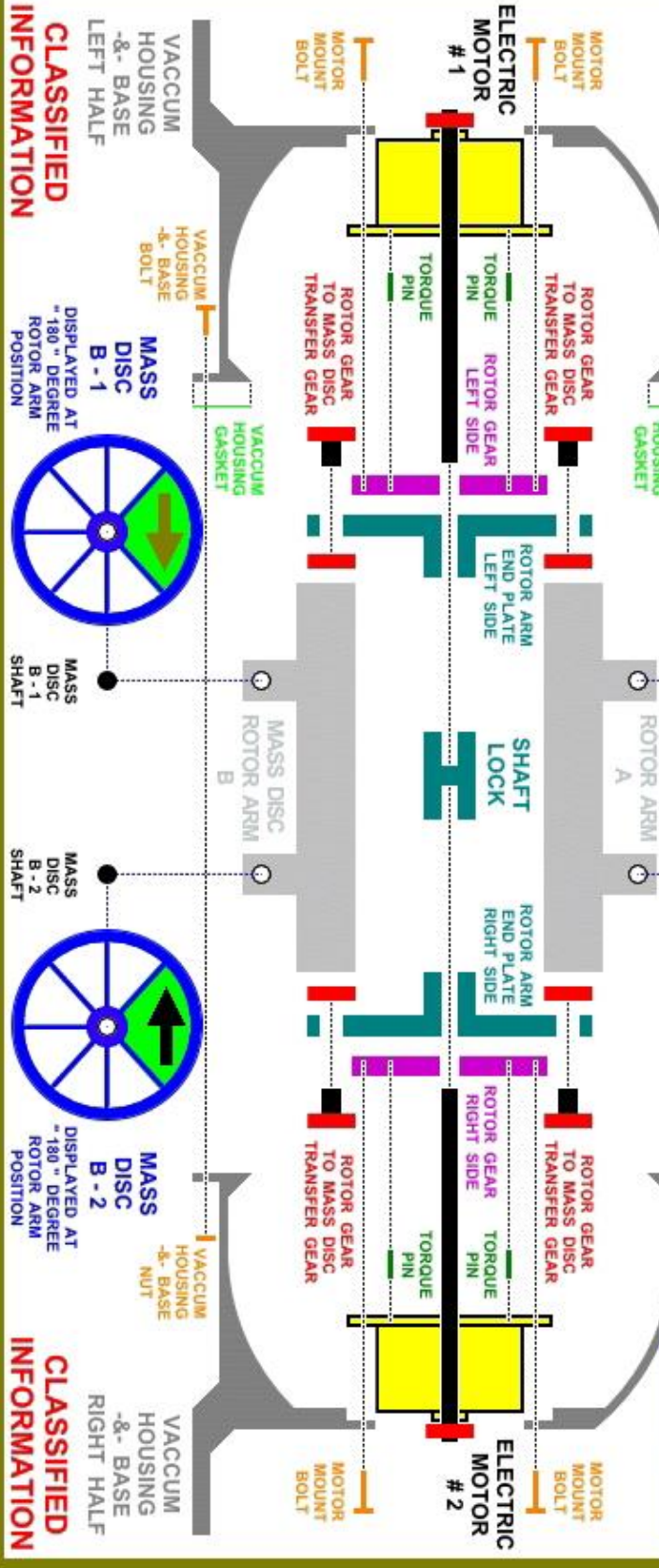
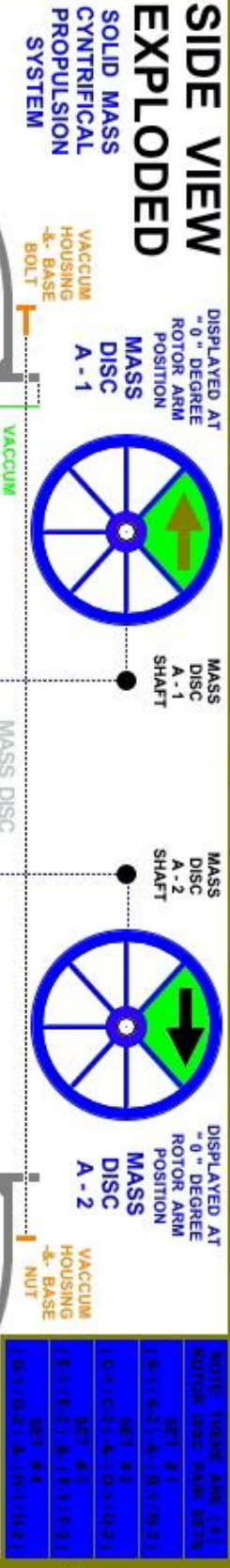
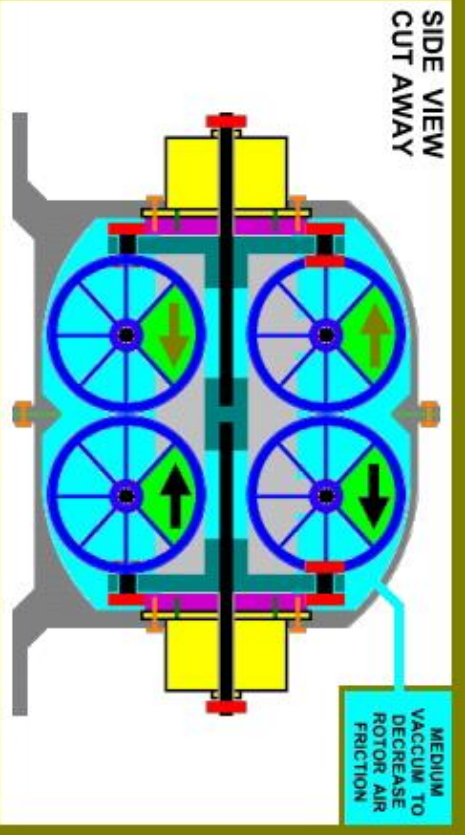
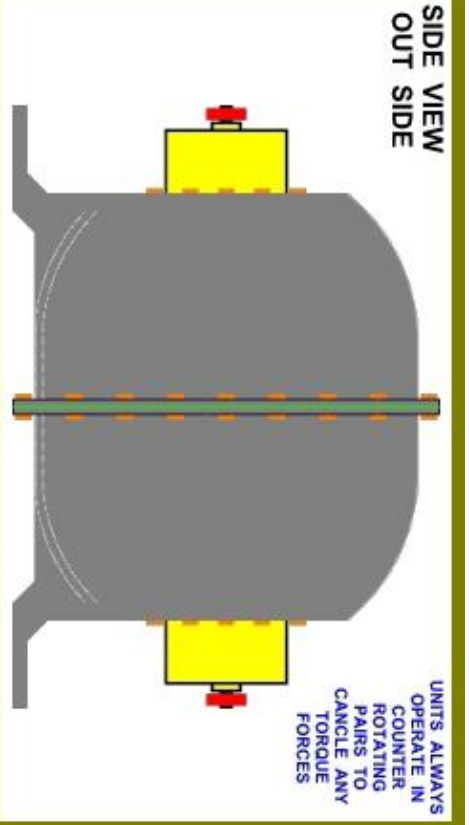

TRADEMARK (TM) -&- COPYRIGHT (C) 1986 TO 2006 , ALL RIGHTS ARE RESERVED

INVENTOR : Mr. Rick R. Dobson, Jr. HIGHLY CLASSIFIED INFORMATION

**END VIEW
OUT SIDE**

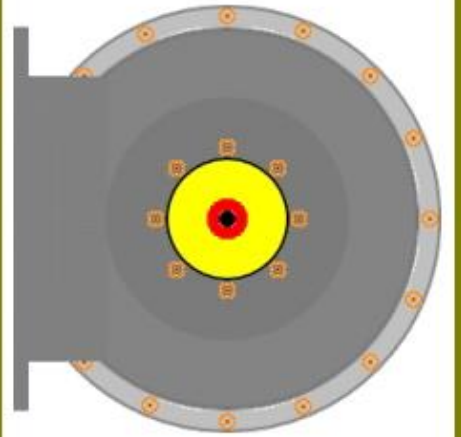

UNITS ALWAYS OPERATE IN COUNTER ROTATING PAIRS TO CANCEL ANY TORQUE FORCES

**END VIEW
CUT AWAY**

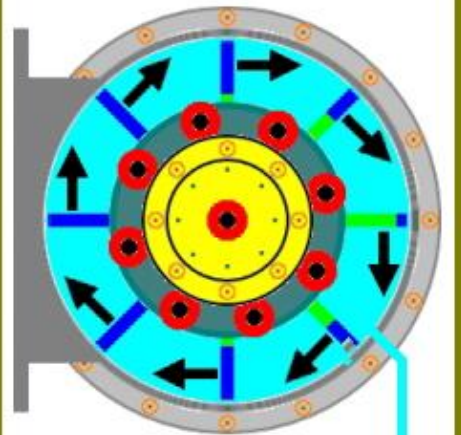

MEDIUM VACUUM TO DECREASE ROTOR AIR FRICTION

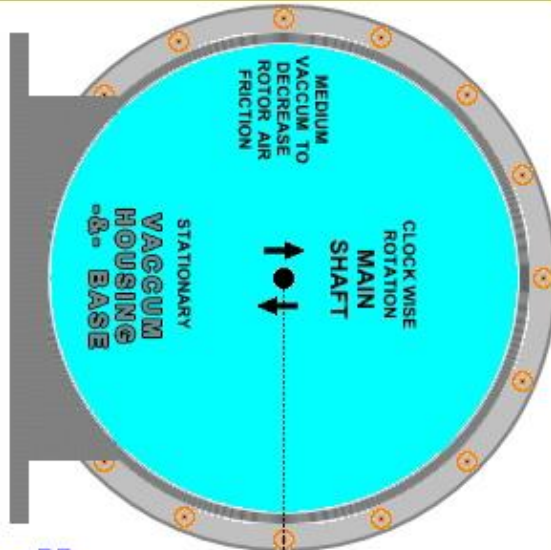

STATIONARY ELECTRIC MOTOR

STATIONARY ROTOR GEAR

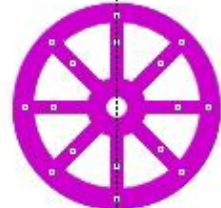
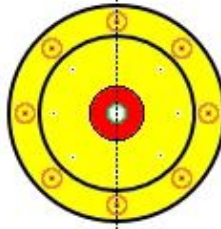

CLOCK WISE ROTATION (ROTOR GEAR TO MASS DISCS)

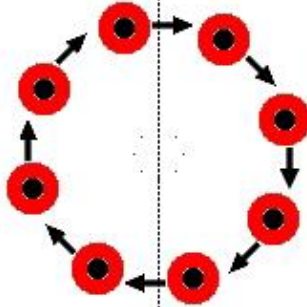

CLOCK WISE ROTATION

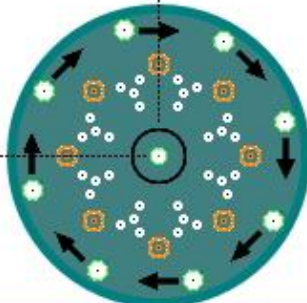

**END VIEW
EXPLODED**

SOLID MASS CENTRIFUGAL PROPULSION SYSTEM

16 MASS DISCS
4 DISC PAIRS OF 2 DISC SETS
CLOCK WISE ROTATION

CLASSIFIED INFORMATION

CLASSIFIED INFORMATION

MASS DISC ROTOR ARMS
CLOCK WISE ROTATION

NOTE: THESE ARE THE ROTOR DISC PAIR SETS
SET #1
1A1, 1B1, 1C1, 1D1, 1E1
SET #2
2A1, 2B1, 2C1, 2D1, 2E1
SET #3
3A1, 3B1, 3C1, 3D1, 3E1
SET #4
4A1, 4B1, 4C1, 4D1, 4E1

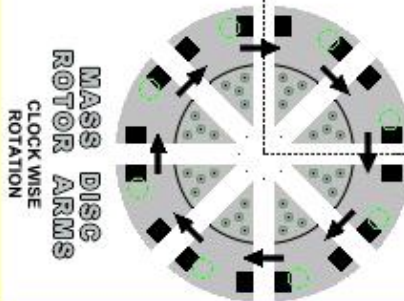
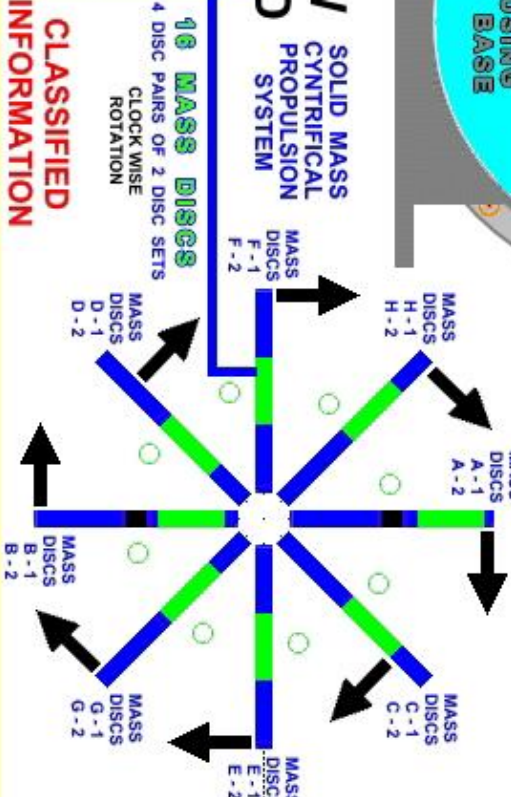

TRADEMARK (TM) -&- COPYRIGHT (C) 1986 TO 2006 , ALL RIGHTS ARE RESERVED

INVENTOR : Mr. Rick R. Dobson, Jr. HIGHLY CLASSIFIED INFORMATION

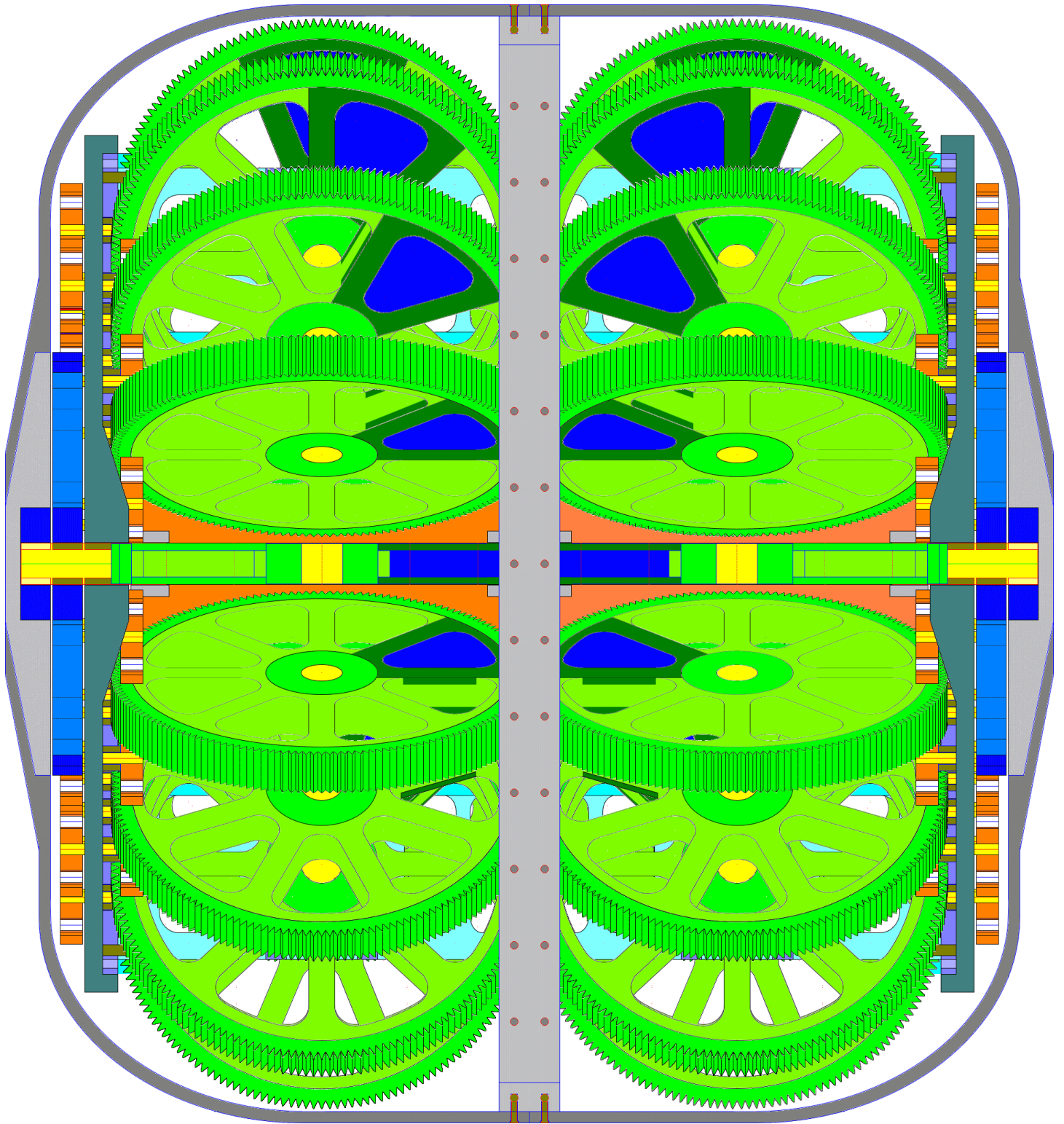



ISA - SM - CPS

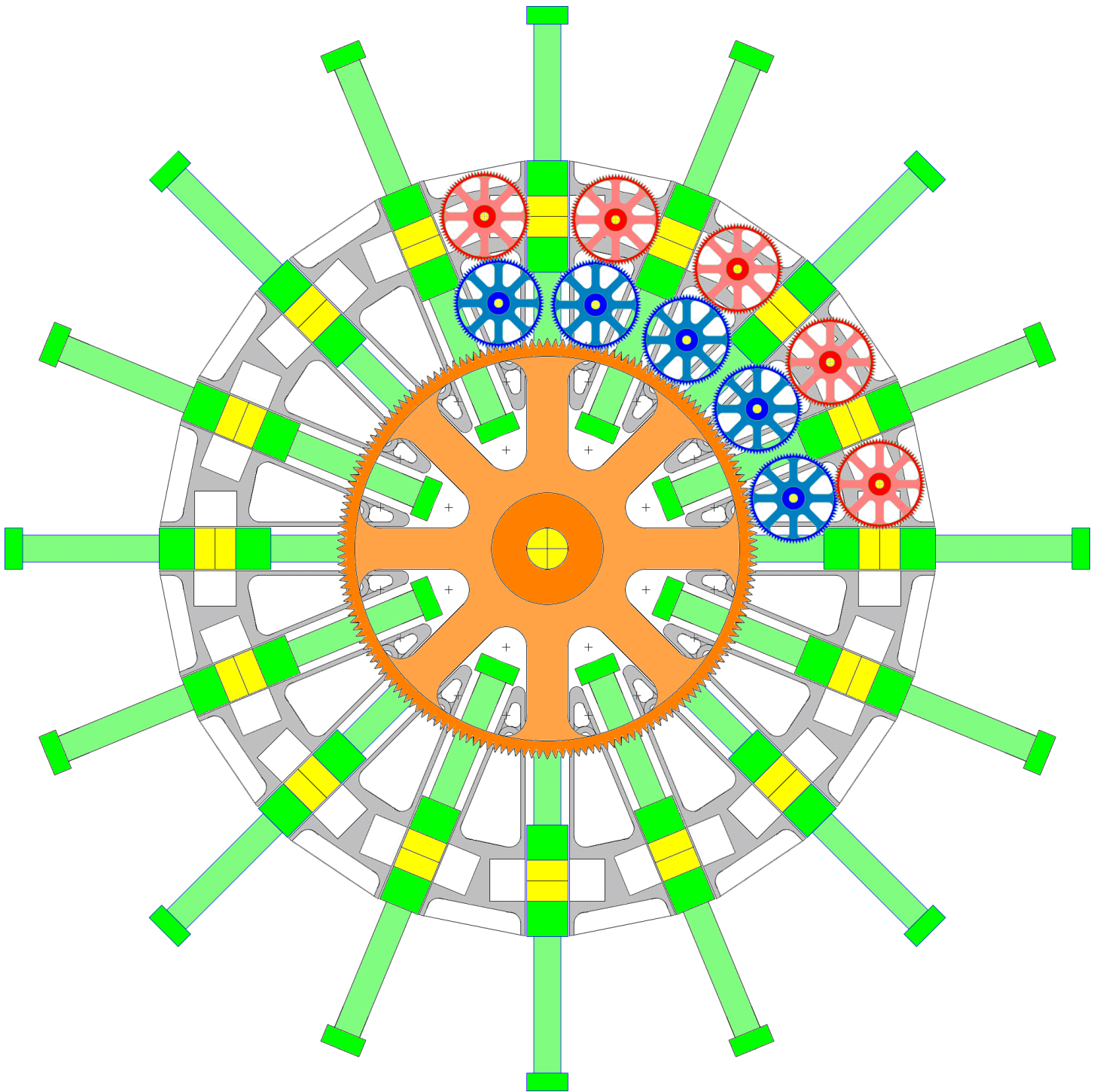

ISA - SM - CPS

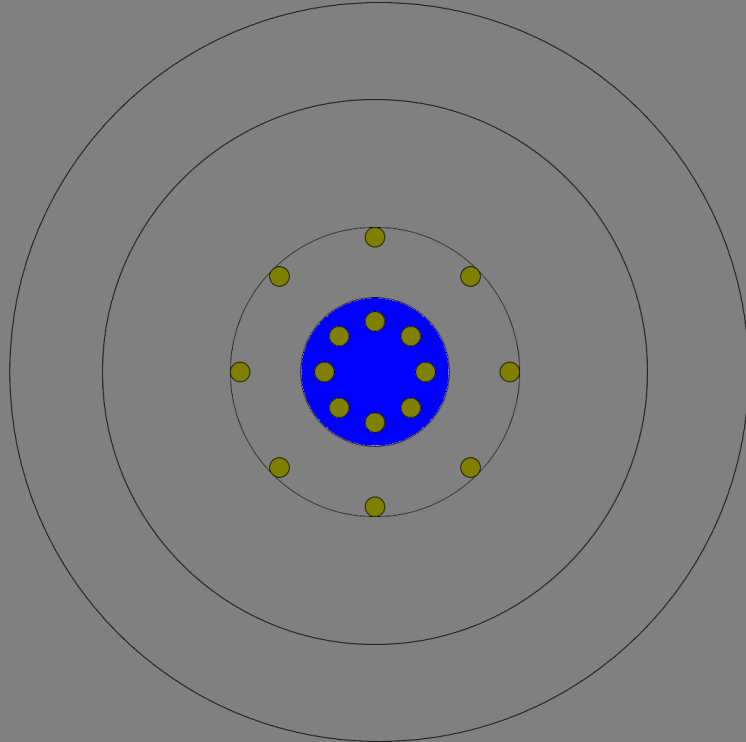

**SOLID MASS - CENTRIFUGAL PROPULSION SYSTEM (ISA - SM - CPS)
 OPERATIONAL EXPERIMENTAL PROTOTYPE UNIT (ISA - OEU - P2013)**

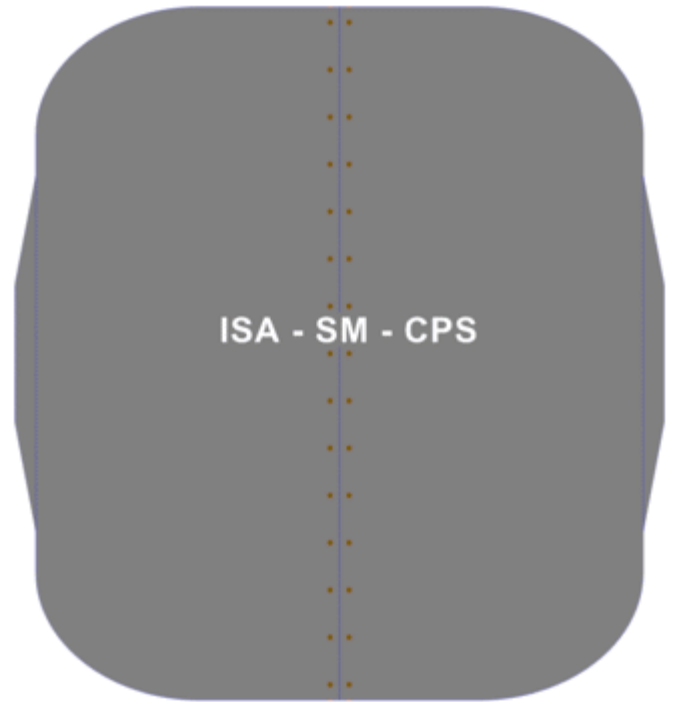
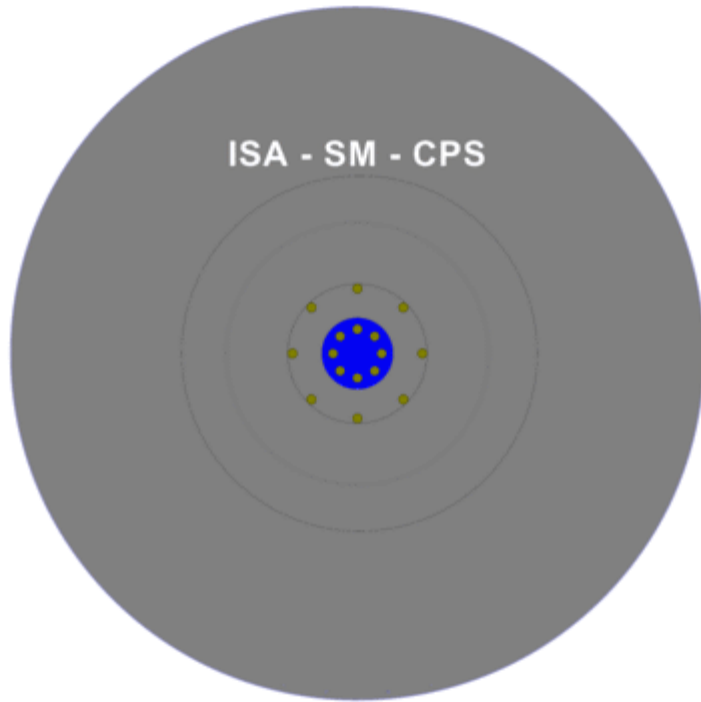

**FRONT VIEW
EXTERNAL**

**PROTOTYPE UNIT
NUMBER - 2
22 JANUARY 2013**

**SIDE VIEW
EXTERNAL**

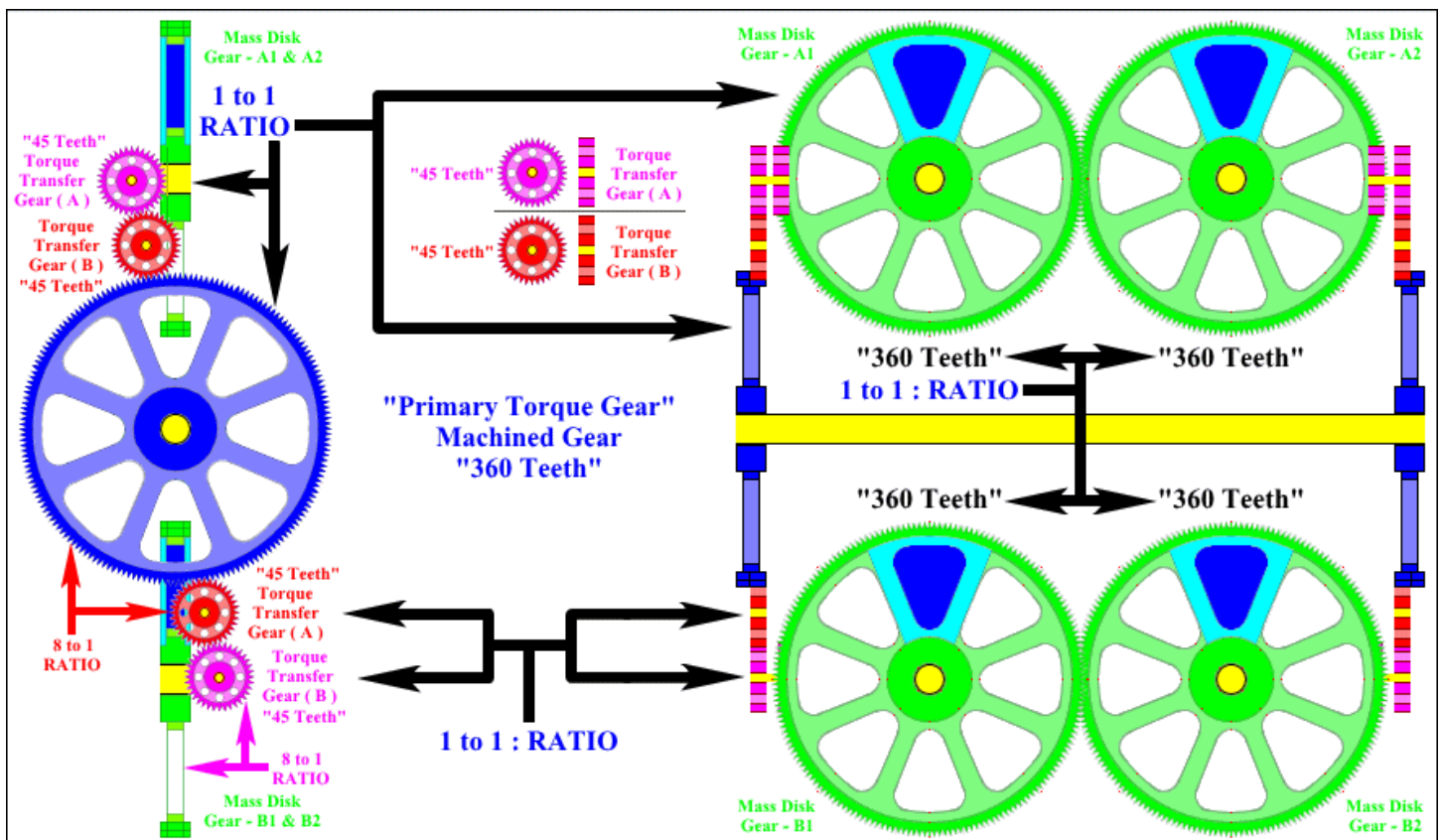

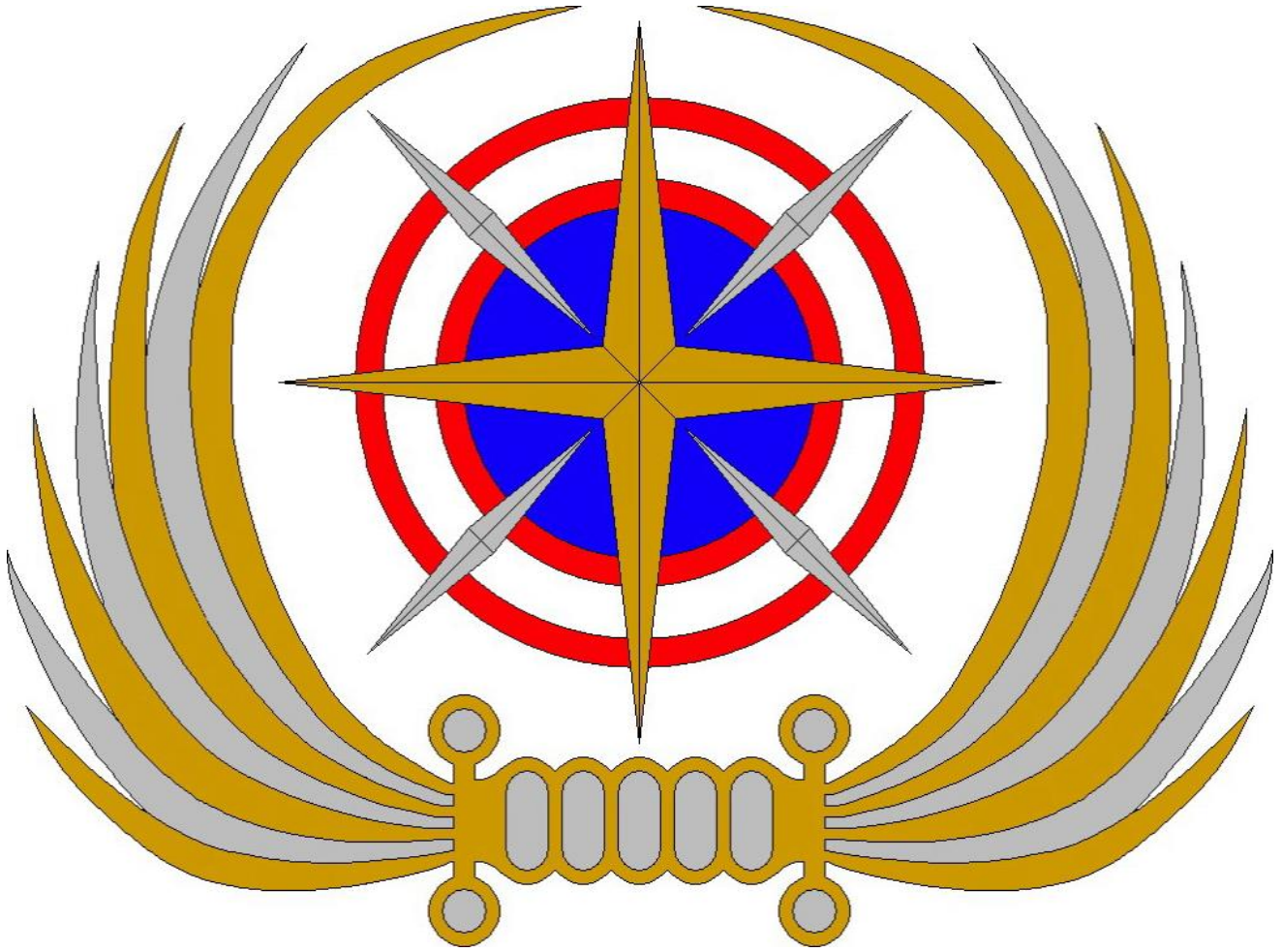

International Space Agency, ISA
International Space Administration
Founded In 1986 -&- Incorporated In 1990
Presently Seeking International Treaty -&- Charter Status

2013 - PROPOSAL

CLOSED LOOP INERTIAL MASS PROPULSION SYSTEM

PROTOTYPE: RESEARCH / DEVELOPMENT / PRODUCTION

Liquid Metal "Mass" Electrostatic (L.M.E.)

Centrifugal Propulsion System (C.P.S.) Program / Office

International Advanced Space Propulsion (I.A.S.P.) Programs / Office



International Space Agency , I.S.A. International Space Administration

Purpose: The *Liquid Metal "Mass" Electrostatic (L.M.E.) Centrifugal Propulsion System (C.P.S.) Program / Office (P.O.)* will function as an important operational department, center, and program office of International Space Agency, and will be a catalyst and enabler to facilitate and support all research and development, for advanced space propulsion, technology, and programs, and act as the central management of Advanced Space Propulsion Capabilities, and Services, Facilities, and Hardware that will be directly or indirectly supporting the vision and mission of the International Space Agency Organization and its Operational Divisions, Departments, Centers, and Commands. **LME-CPS-PO** will also be the command and control authority of all **Closed Loop Propulsion Research and Development Efforts and Activities** of the **International Advanced Space Propulsion (I.A.S.P.) Program / Office**, and will include the collective personnel resources of **LME-CPS-PO** Officers, Management, Technicians, and Staff. **LME-CPS-PO** will support and carry out all Research & Development of Closed Loop Propulsion Capabilities for advanced international space technology programs, projects, missions, and advanced international space research and development activities, for the **ISA**, and its member states & organizations, and Globally as approved by its members. **SPECIFICALLY: CLOSED LOOP PROPULSION TECHNOLOGY**

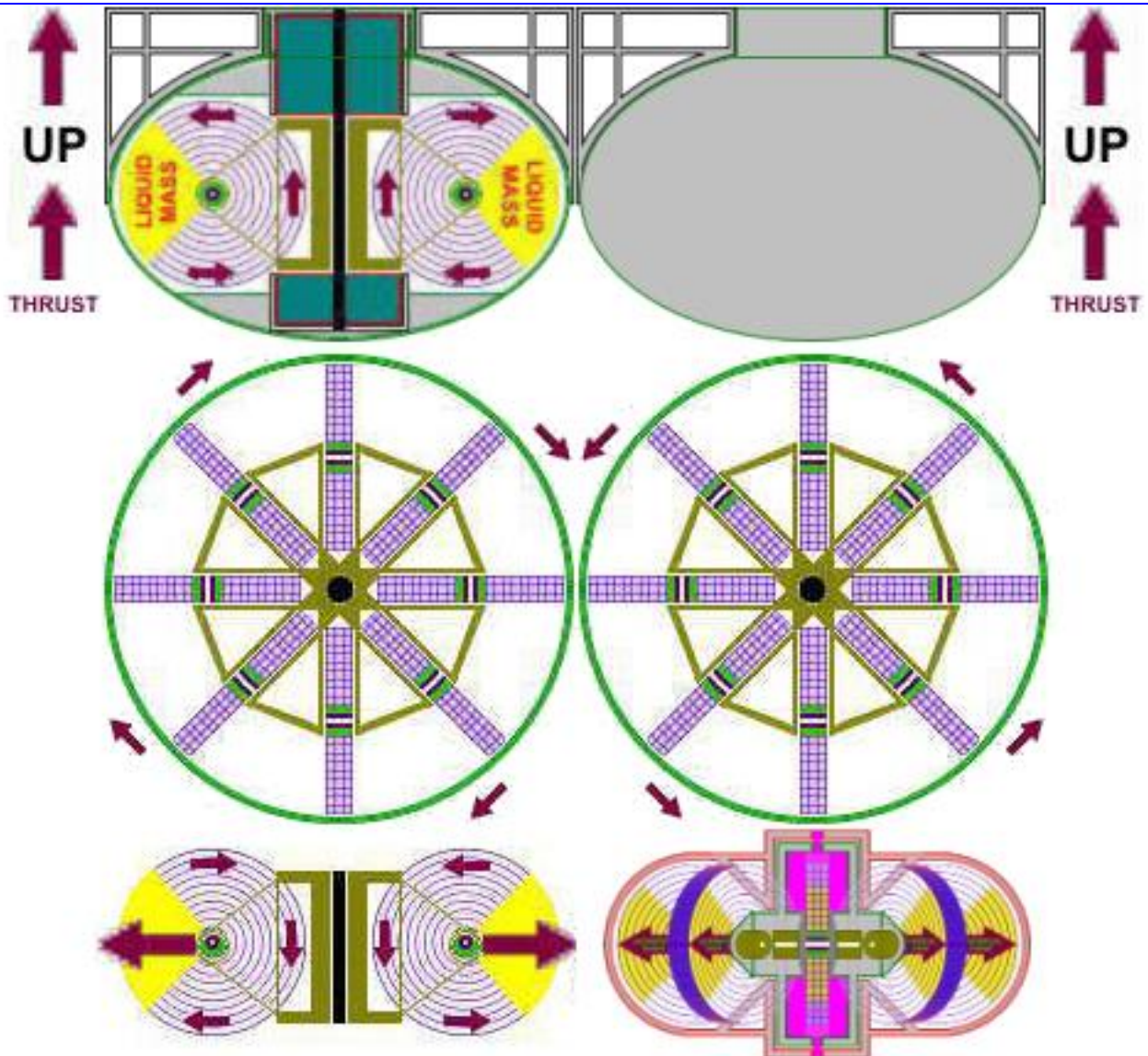

Liquid Metal "Mass" Electrostatic (L.M.E.) Centrifugal Propulsion System (C.P.S.) Program

M. General Information

	<p>Project Title: <i>Liquid Metal "Mass" Electrostatic (LME) Centrifugal Propulsion System (CPS) Program / Office Operations & Programs / Research & Development</i> <i>An Internal Department of the International Advanced Space Propulsion (I.A.S..P) Programs / Office</i></p> <p>Brief Project Description: LME-CPS-PO will support and carry out all Research & Development of Closed Loop Propulsion Capabilities for advanced international space technology programs, projects, missions, and advanced international space research and development activities, for the International Space Agency, and its member states and organizations, and Globally as approved by its members. Specifically "Closed Loop Propulsion" Technology.</p> <p>Prepared By: Dr. Thorsteinn Olafsson – Iceland Director, Liquid Metal "Mass" Electrostatic (LME) Centrifugal Propulsion System (CPS) Program / Office, I.S.A. Mr. Rick R. Dobson, Jr. - United States – Founder, Chairman, CEO, International Space Agency</p> <p>Date: 15th of October, 2013</p>
--	--

N. Project Objectives:

PURPOSE: The **Liquid Metal "Mass" Electrostatic (L.M.E.) Centrifugal Propulsion System (C.P.S.) Program / Office (P.O.)** will function as an important operational department, center, and program office of International Space Agency, and will be a catalyst and enabler to facilitate and support all research and development, for advanced space propulsion, technology, and programs, and act as the central management of Advanced Space Propulsion Capabilities, and Services, Facilities, and Hardware that will be directly or indirectly supporting the vision and mission of the International Space Agency Organization and its Operational Divisions, Departments, Centers, and Commands. **LME-CPS-PO** will also be the command and control authority of all **Closed Loop Propulsion Research and Development Efforts and Activities** of the **International Advanced Space Propulsion (I.A.S.P.) Program / Office**, and will include the collective personnel resources of **LME-CPS-PO** Officers, Management, Technicians, and Staff. **Note: Proprietary Research & Schematics has already been achieved.**

CAPABILITY: Liquid Metal "Mass" Electrostatic (LME) Centrifugal Propulsion System (CPS) is a technology that harnesses the inertia effect found in high rotational bodies "Mass", which leads to forward thrust and does not require finite mass to be ejected in the opposite direction; like presently found in chemical rocket nozzles or jet engines, in order to produce thrust. This is therefore a **"Closed Loop Propulsion System"** which means that it does not require finite mass to be ejected in the opposite direction to produce forward thrust, as is presently the case in all conventional propulsion systems in use today. This discovery will revolutionize space travel, by enabling us to explore our solar system in more efficient manner. Chemical Rockets "Disposable Ejected Finite Reaction Mass" will not provided effective propulsion capabilities for travel over the great distances between Planets, with in the vast spaces of the Solar System, and Beyond. Therefore, it is critical, paramount, that a NEW form of "Closed Loop Propulsion" be researched & investigated, with the focus to be developed.

The discovery of these mathematical inertia formulas, will lead to detailed explanations for **"Closed Loop Propulsion"** effect. These mathematical equations and explanations once available, will at the same time, explain other things within physics, which so far have not been properly understood. It is a closer approach to what is really taking place in Orbital Mechanics, Electron Orbits in Atoms, and Electron Emissions from High Rotational Bodies "Like A Star". At the same time these discoveries will lead to the fact, that it will be possible to harness this effect, and then in a much more efficient manner produce constant thrust for long durations for long distant travel between planets, and with in the vast spaces of our Solar System, and beyond. In the Centrifugal "Inertial" Propulsion System, the **"REACTION MASS"** is suspended in a **"Dobson Centrifugal Field"**, and this **"Energy/Mass Suspended in a High Rotational Field"**, This **"Rotary Mass / Energy"** is then converted to **"Linier Mass / Energy-Thrust"**. Therefore, the finite reaction mass is not EJECTED out the rear of the propulsion system like in all propulsion systems presently in use today. In a "Closed Loop Propulsion System", the reaction mass is reused perpetually, and is suspended/stored in a high rotational field.

In this regards, the propulsion device is causing a synchronized and directionally focused disruption or imbalance with regards to the center of rotational mass within the given object or device, therefore leading to forward thrust or propulsion. If we go further into this the imbalance and the forward thrust and movement is directly related to the physics properties found in the Higgs-Field itself. The Higgs-field has on the other hand to do with properties that are linked to dark energy. Such calculations concerning this need to be further explored and defined. Funding will be required to bring this advanced technology about, and then to develop it fully.

BENEFITS: The Centrifugal "Inertial" Propulsion System will provide Constant & Perpetual Thrust as long as electrical power is supplied to its electric drive motors in the case of the use of Solid Mass and Mechanical Means; or its electromagnetic repulsor drive elements in the case of the use of Liquid "Metal" Mass and Magnetic Containment and Suspension Means. All reaction mass would be perpetually "suspended" and self-contained with in the propulsion system. This will allow travel over vast distances in space.

FUNDING: A Single or Combined, Grant or Donation, in the sum of One Million U.S. Dollars (\$ 1,000,000) is sought, to fund a 3 year Classified Research and Development Program, to obtain key Scientific & Engineering Personnel, Facilities, Equipment, and Materials required to research, conceive, develop, and build a fully operational CPS prototype with in a 3 to 5 year deadline.

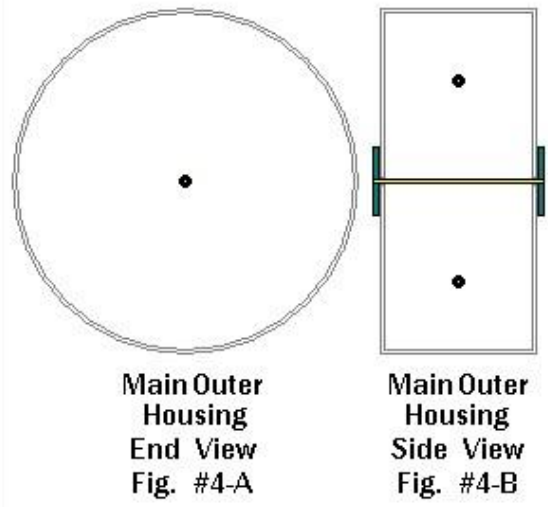
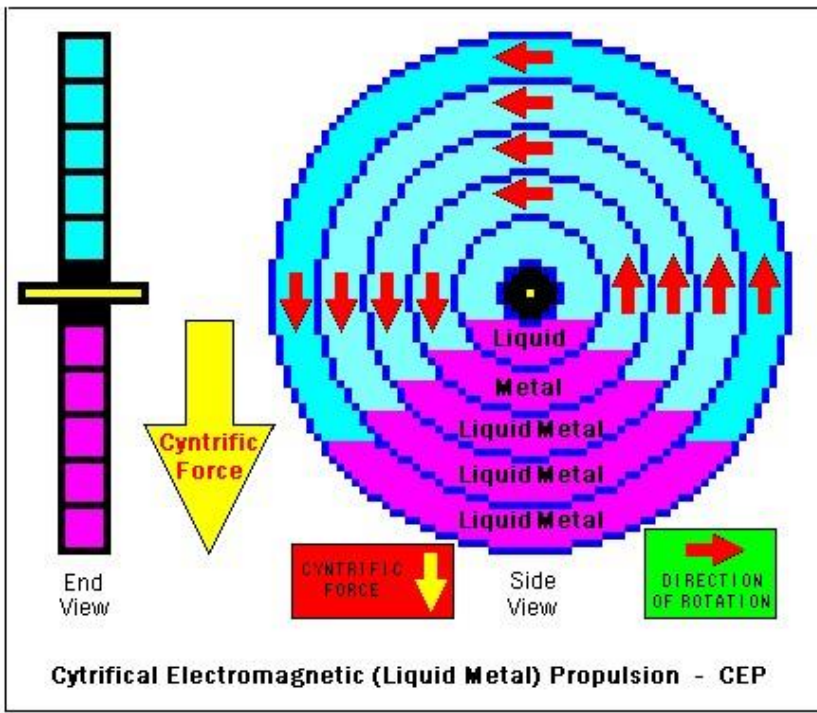
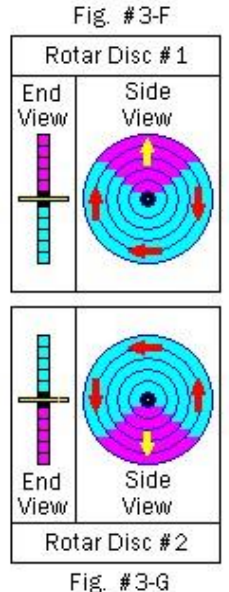
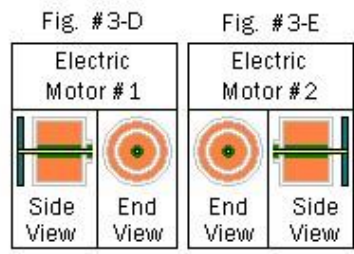
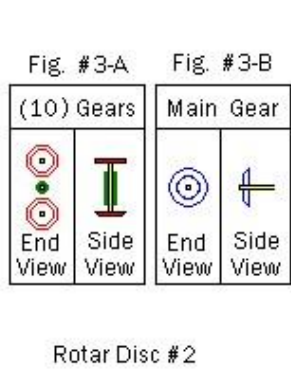
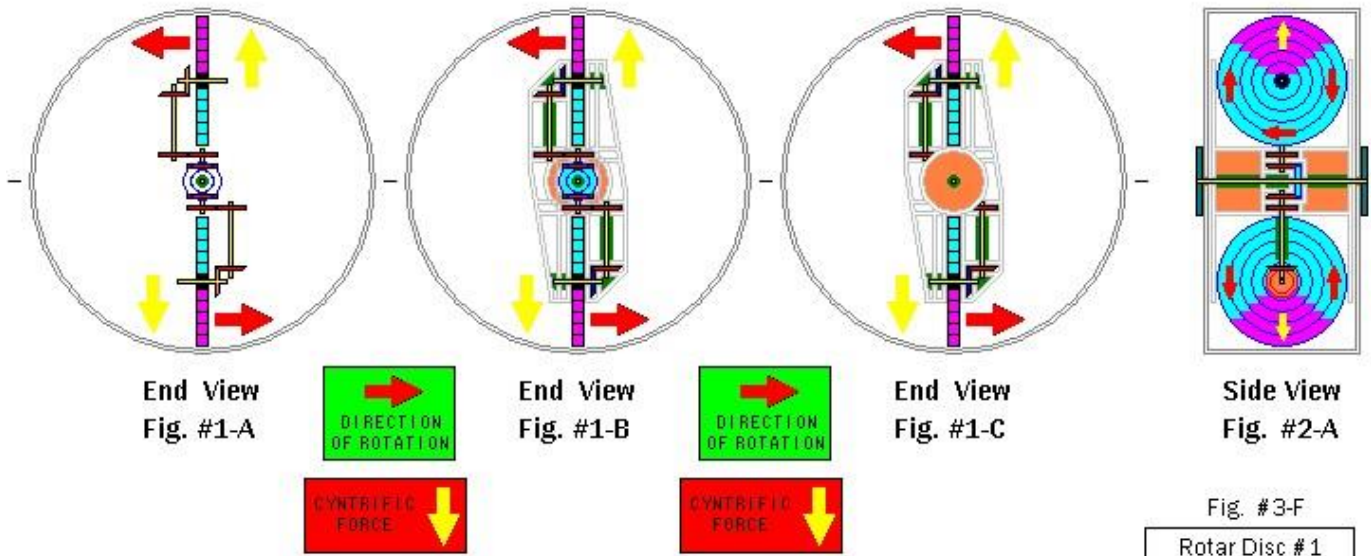

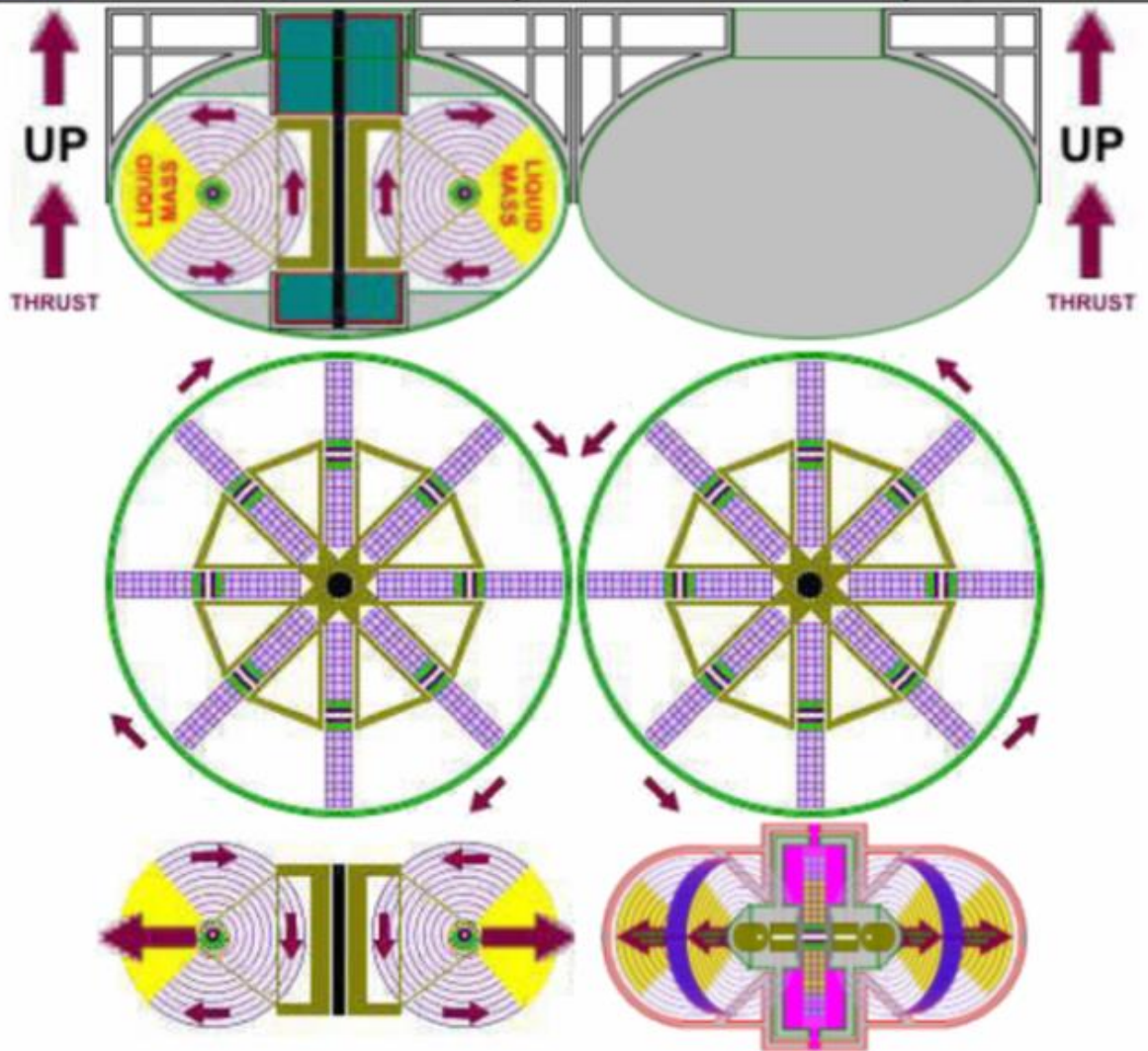
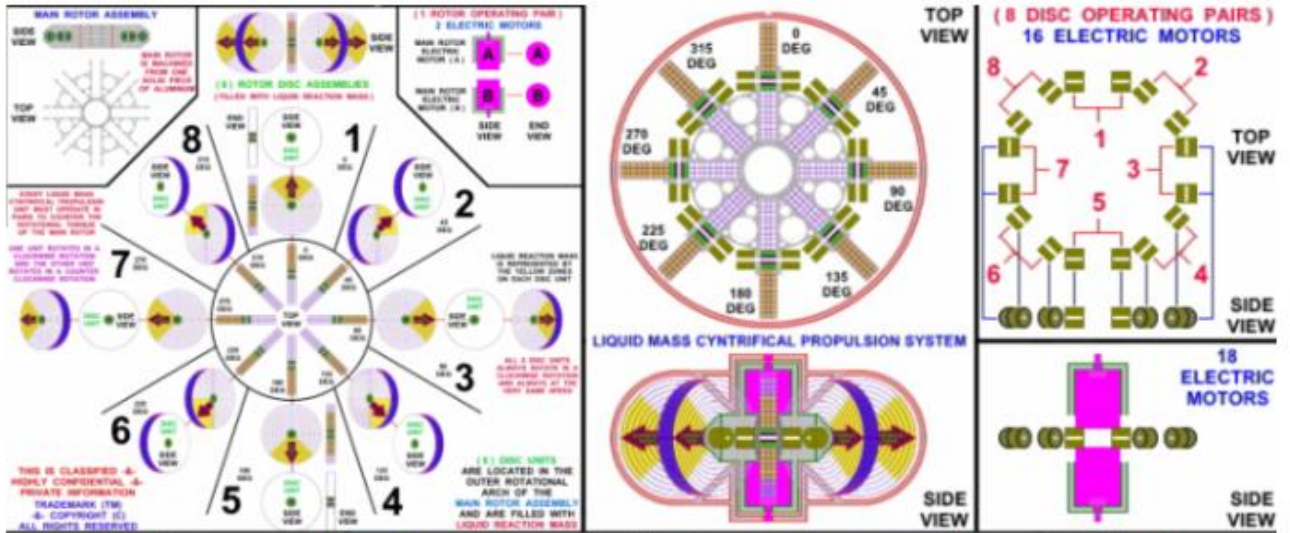

Liquid Metal "Mass" Electrostatic (L.M.E.) Centrifugal Propulsion System (C.P.S.) Program

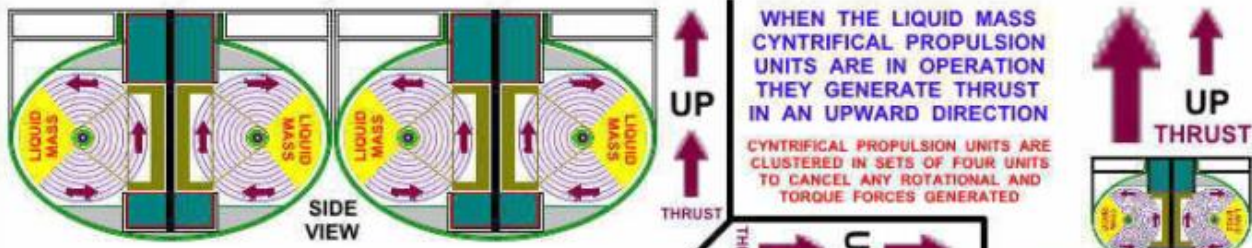

WHEN THE LIQUID MASS CYNTRIFICAL PROPULSION UNITS ARE IN OPERATION THEY GENERATE THRUST IN AN UPWARD DIRECTION

CYNTRIFICAL PROPULSION UNITS ARE CLUSTERED IN SETS OF FOUR UNITS TO CANCEL ANY ROTATIONAL AND TORQUE FORCES GENERATED

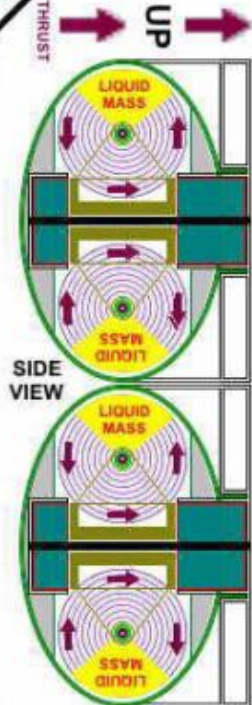
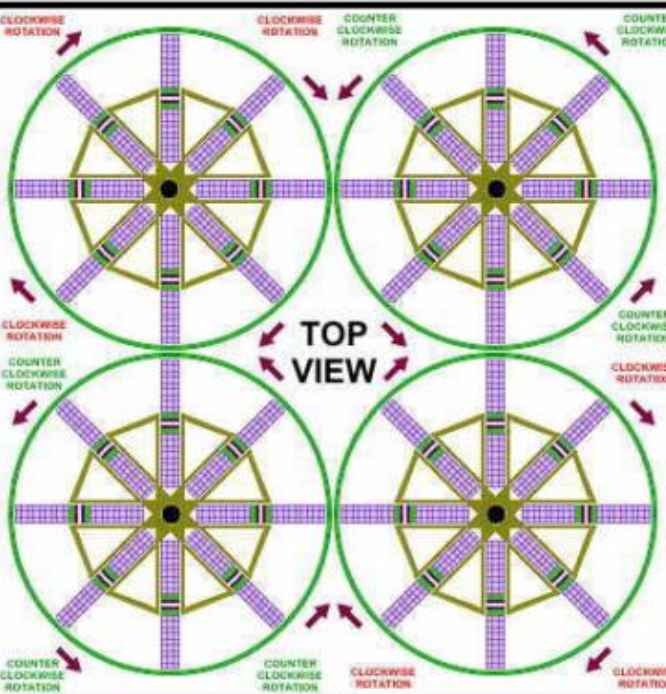

MAIN ROTOR ASSEMBLY AND ROTAR DISCS ARE SPUN AT HIGH SPEED BY ELECTRIC MOTORS

ROTOR DISCS ALL CONTAIN LIQUID MASS SUSPENDED IN A CYNTRIFICAL FIELD

LIQUID MASS CENTRIFICAL PROPULSION SYSTEM

ROTOR DISCS ALL CONTAIN LIQUID MASS SUSPENDED IN A CENTRIFICAL FIELD ON THE OUTSIDE ROTATIONAL ARC OF THE MAIN ROTOR ASSEMBLY (OUTSIDE SECTOR OF EACH ROTAR DISC)

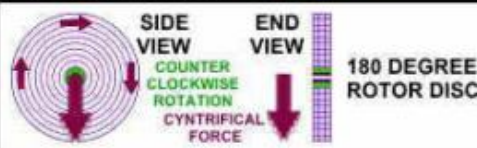
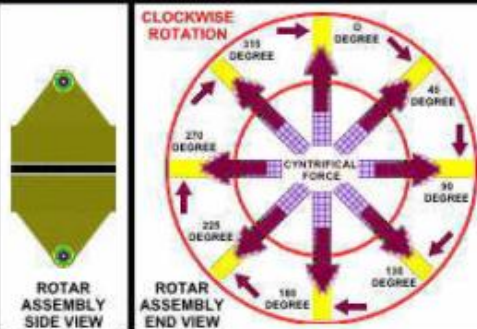
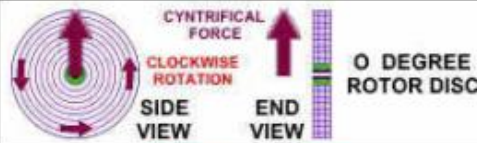
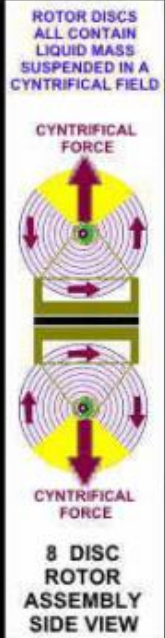
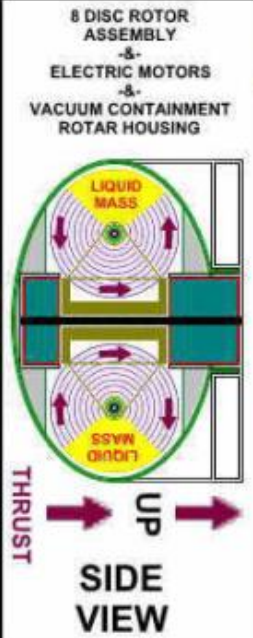
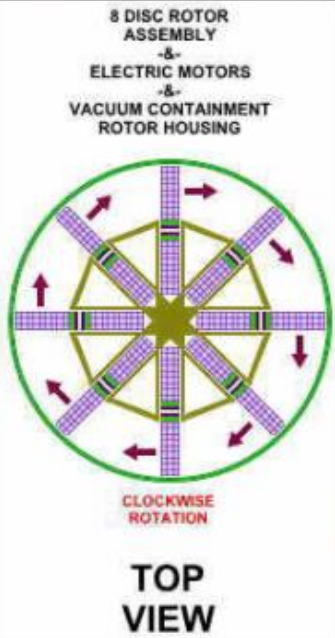

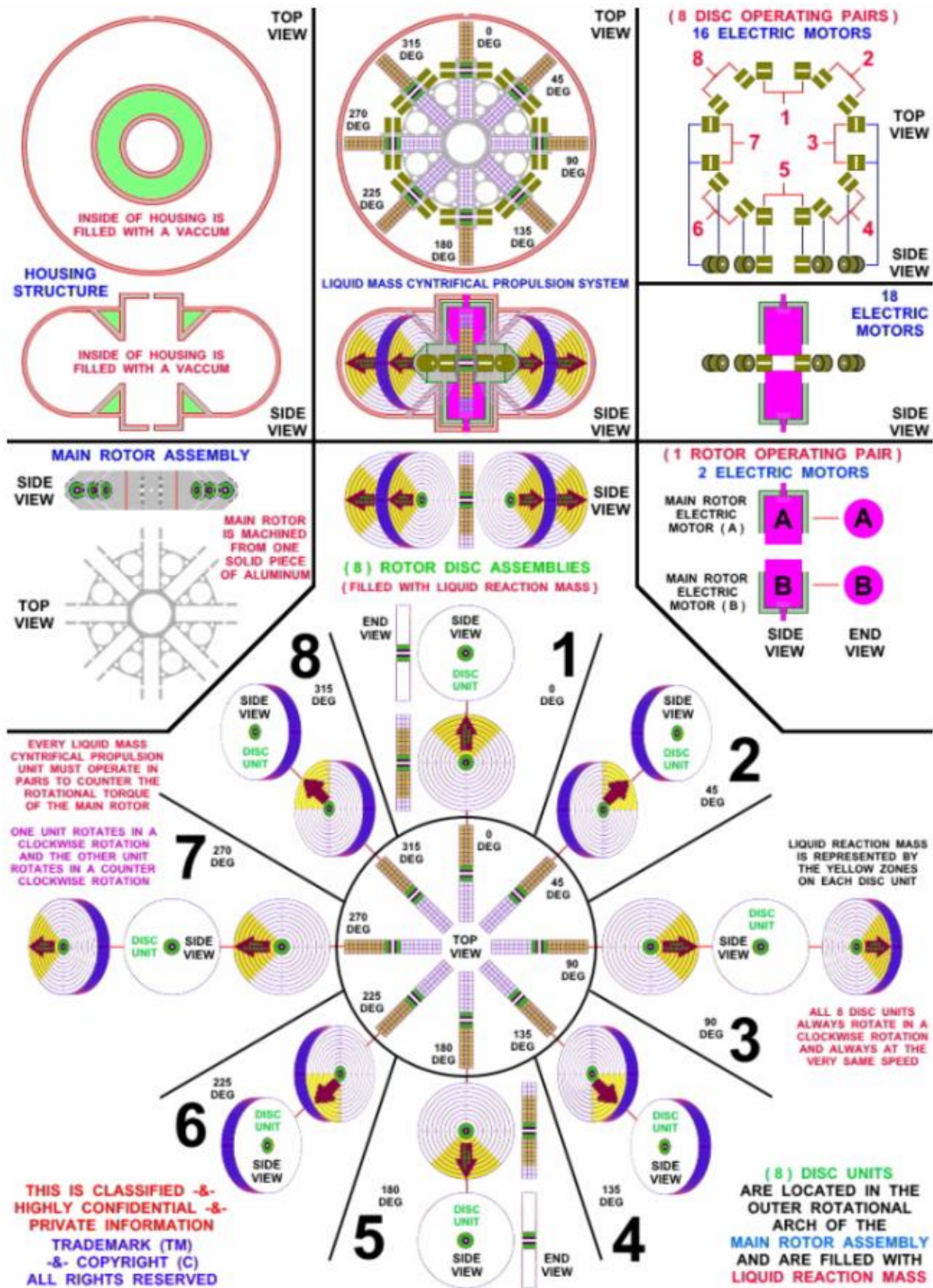

THIS IS CLASSIFIED -&-
 HIGHLY CONFIDENTIAL -&-
 PRIVATE INFORMATION
 TRADEMARK (TM)
 -&- COPYRIGHT (C)
 ALL RIGHTS RESERVED

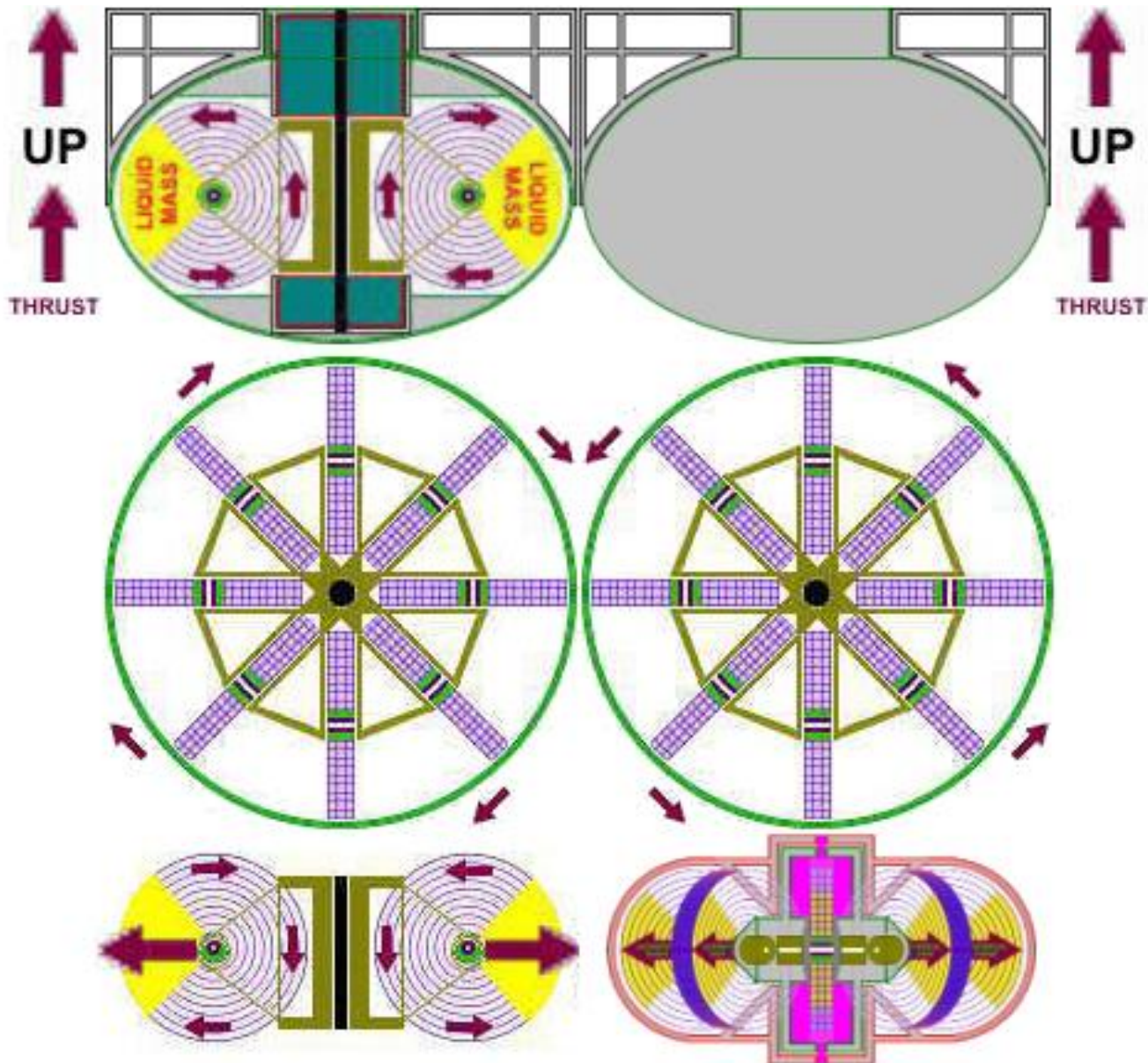

Liquid Metal "Mass" Electrostatic (L.M.E.) Centrifugal Propulsion System (C.P.S.) Program

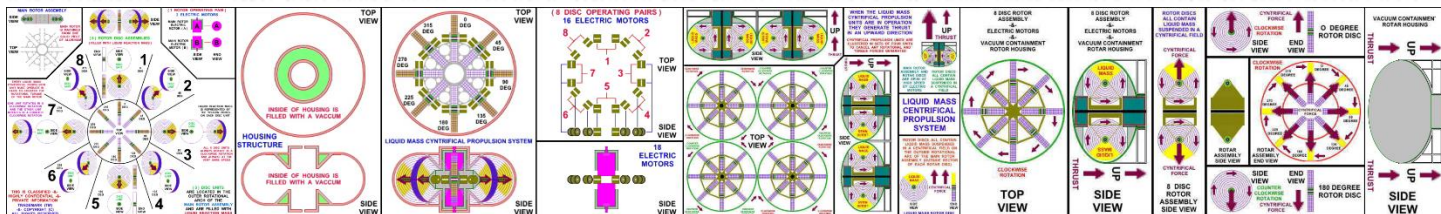

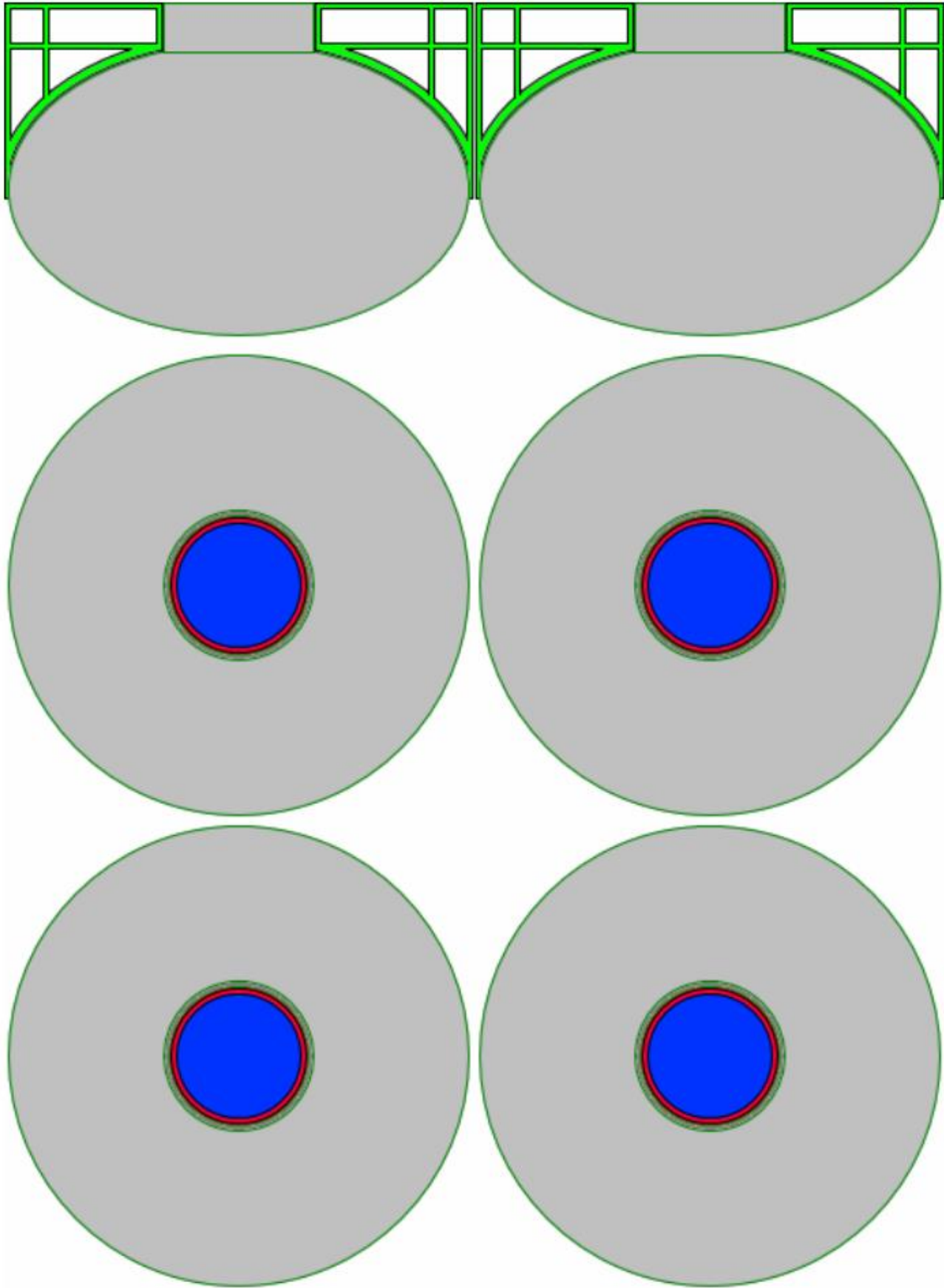

Liquid Metal "Mass" Electrostatic (L.M.E.) Centrifugal Propulsion System (C.P.S.) Program

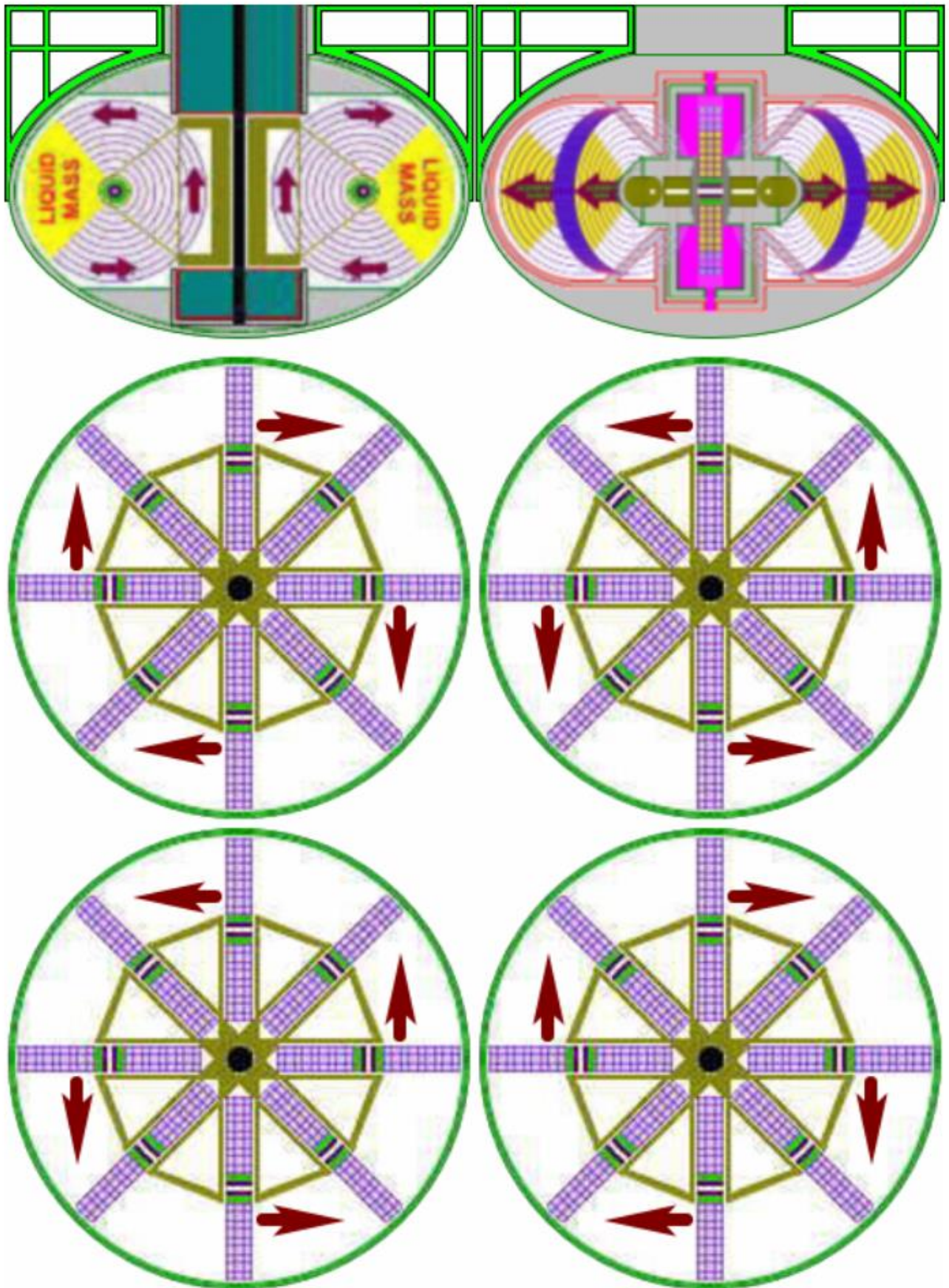

Liquid Metal "Mass" Electrostatic (L.M.E.) Centrifugal Propulsion System (C.P.S.) Program



**INTERNATIONAL
LIFTER SHIPS (I.L.S)
PROGRAM**

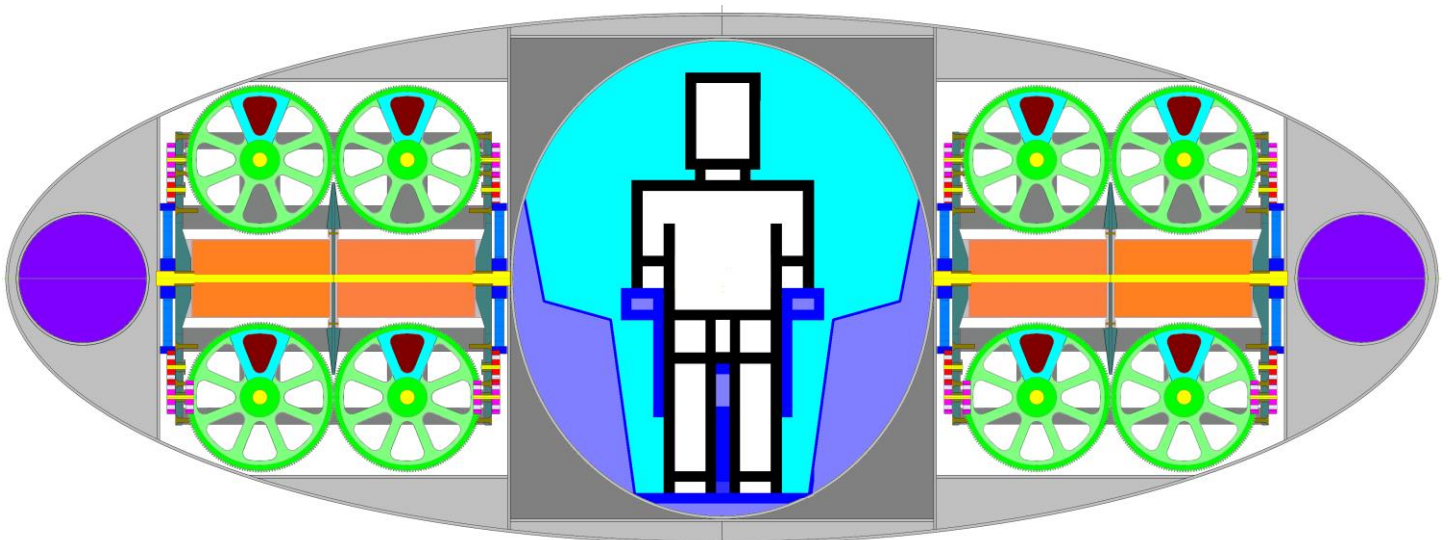

This Is Exclusive Property Of The International Space Agency, I.S.A.

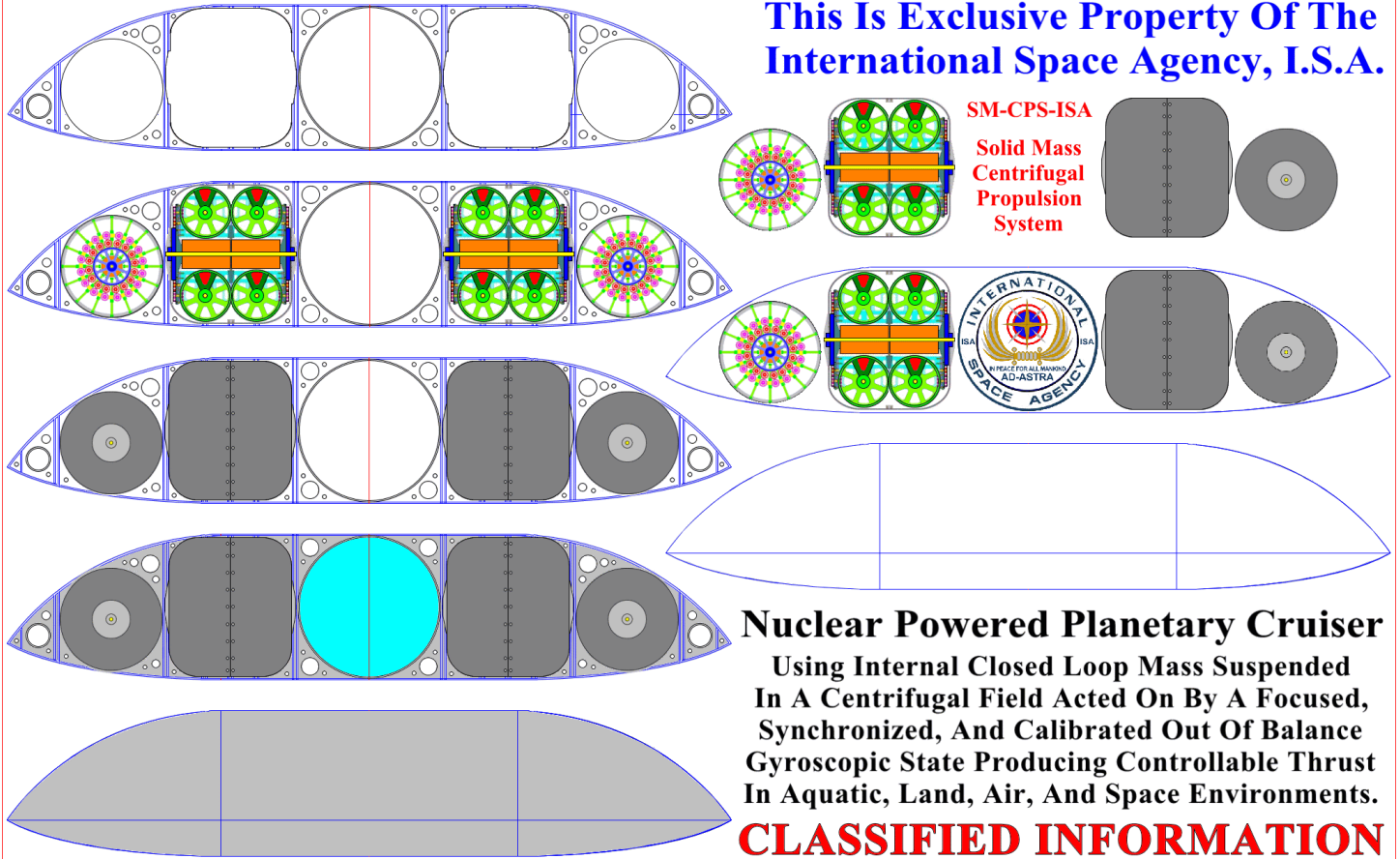

Nuclear Powered Planetary Cruiser
Using Internal Closed Loop Mass Suspended In A Centrifugal Field Acted On By A Focused, Synchronized, And Calibrated Out Of Balance Gyroscopic State Producing Controllable Thrust In Aquatic, Land, Air, And Space Environments.
CLASSIFIED INFORMATION

Patent Pending, Registered Trademark & Copyrights, 1986 to 2013, All Rights Are Reserved

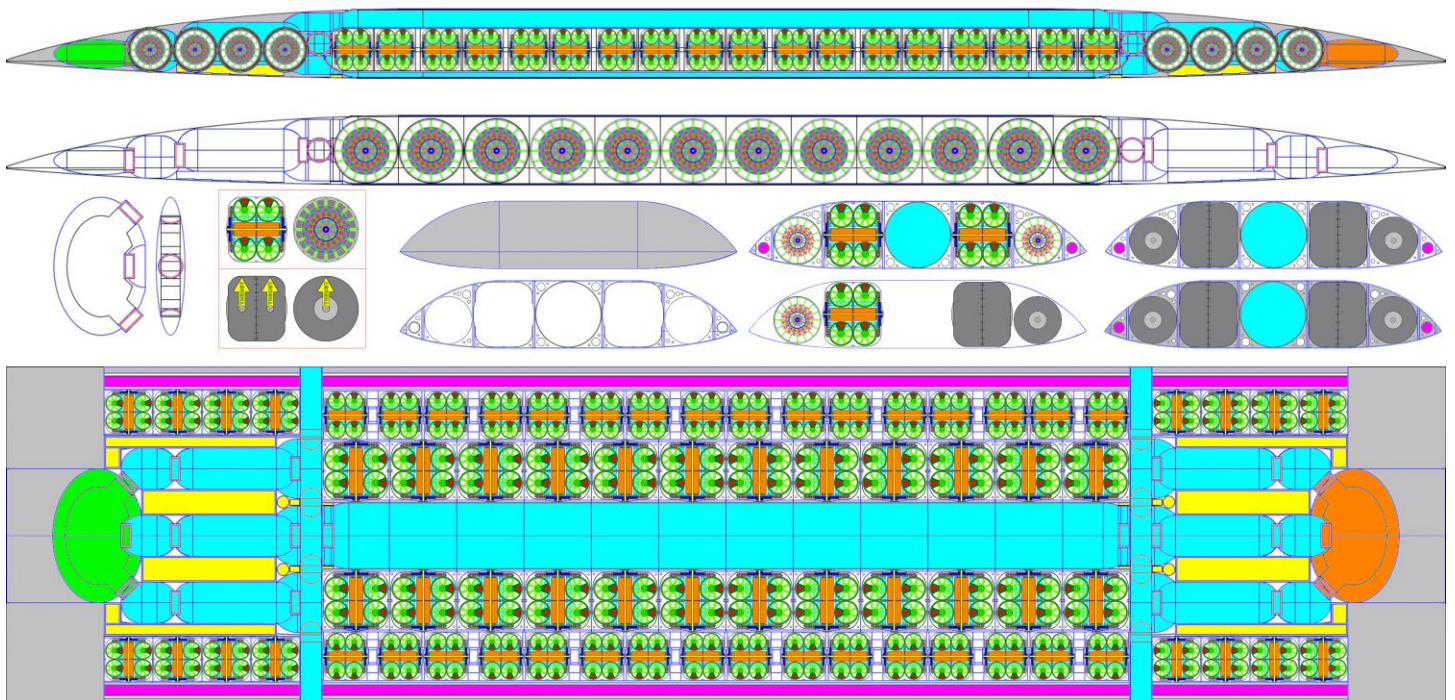

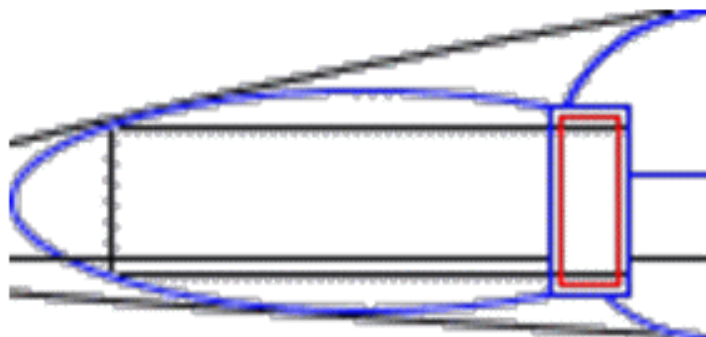
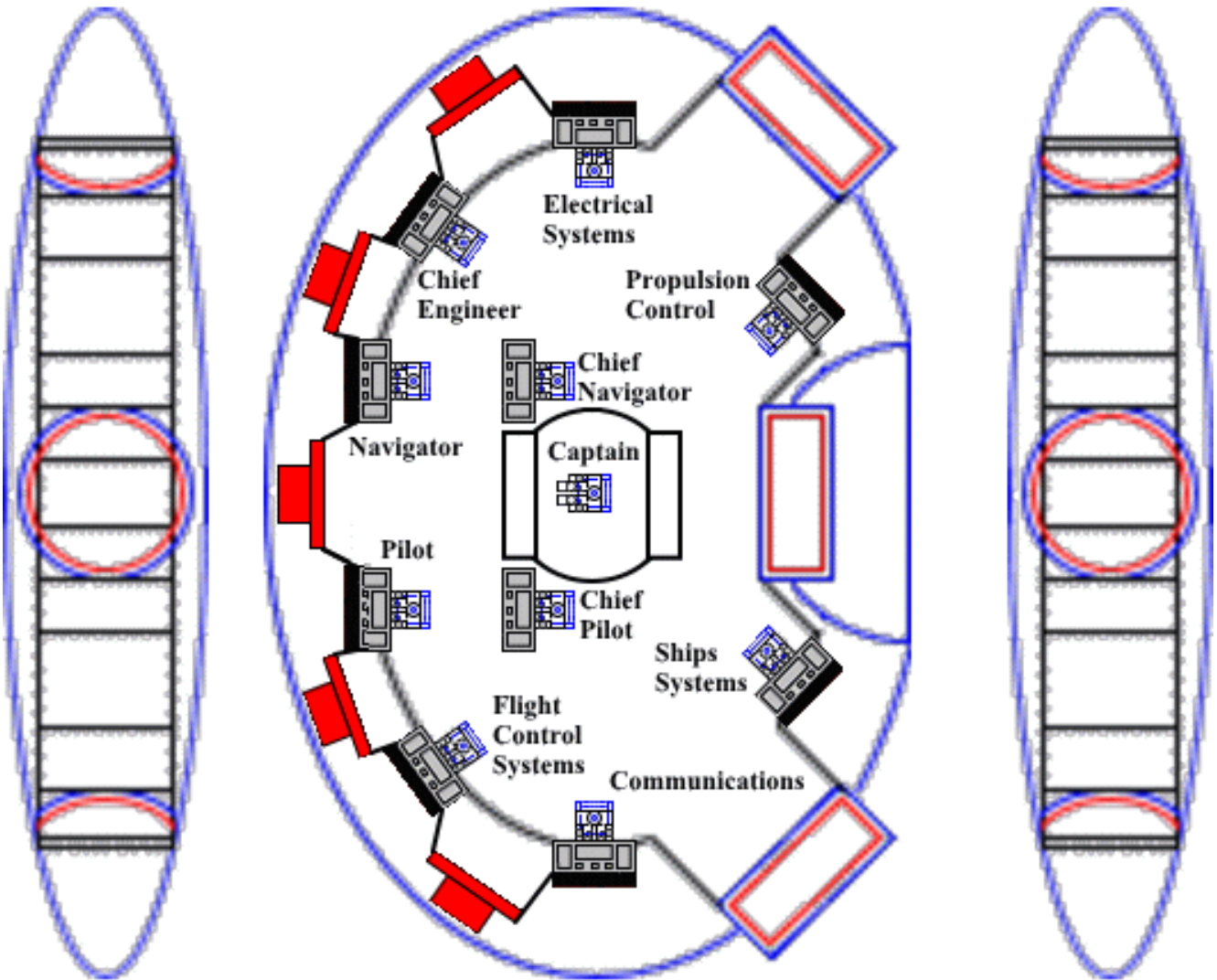

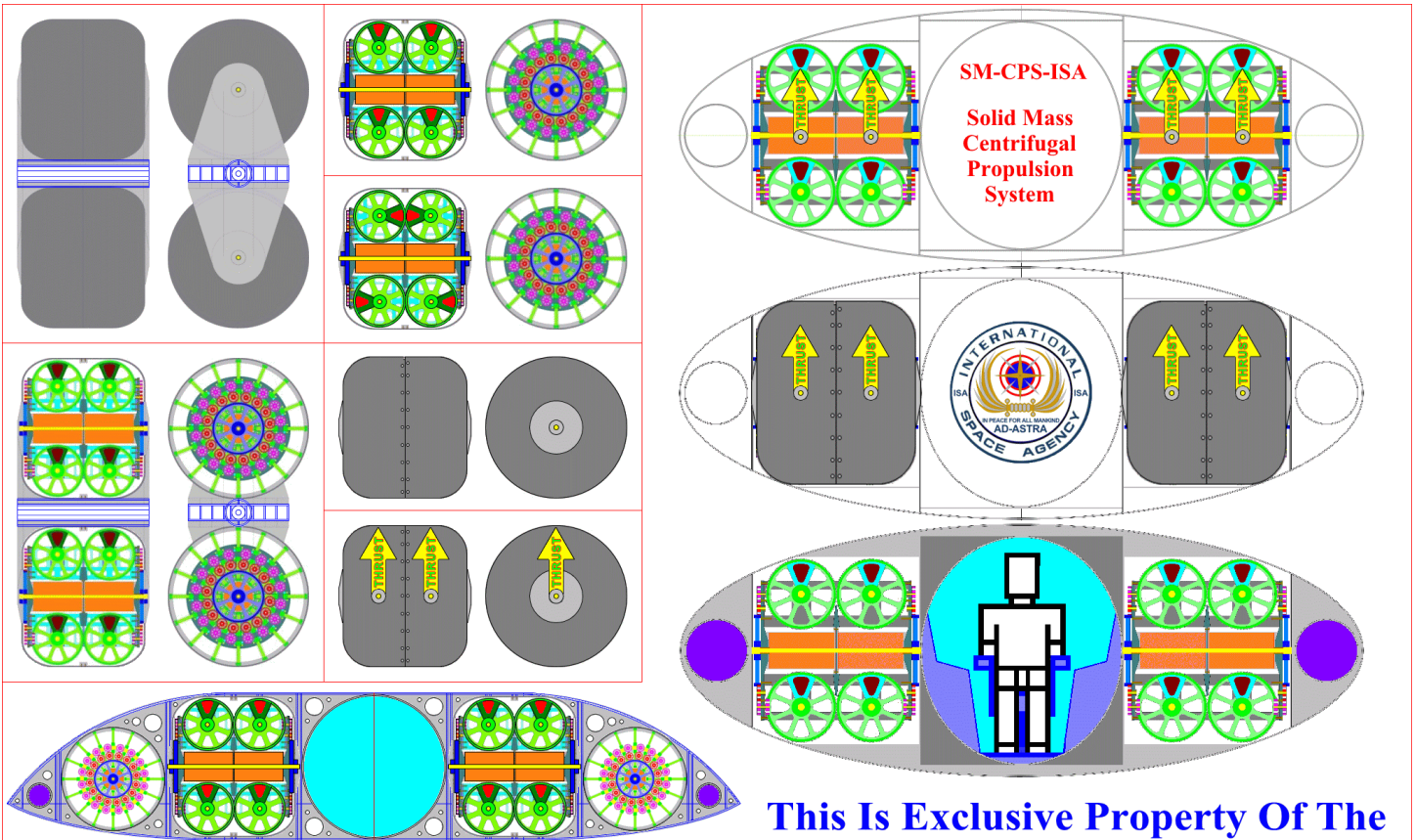

CLASSIFIED INFORMATION
 Patent Pending, Registered Trademark & Copyrights, 1986 to 2013, All Rights Are Reserved

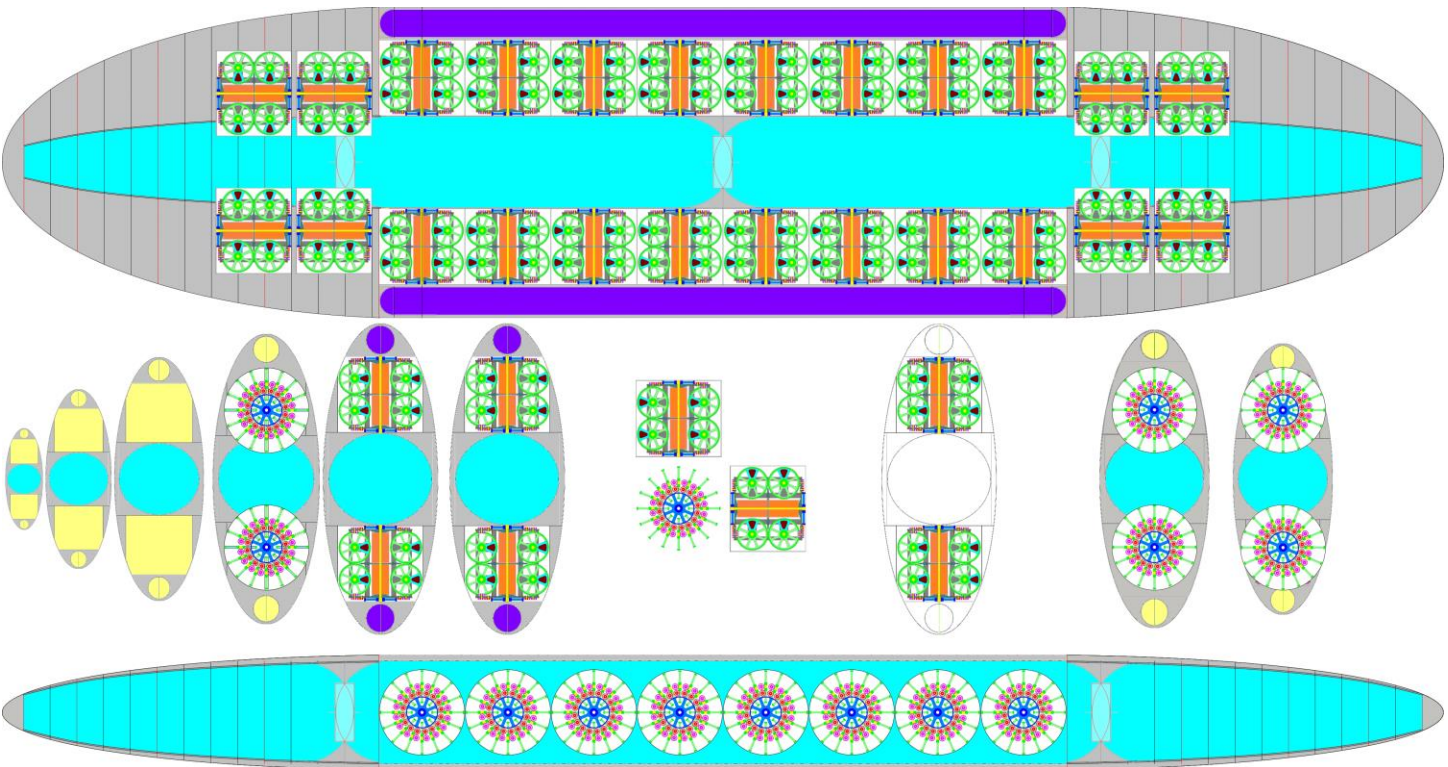

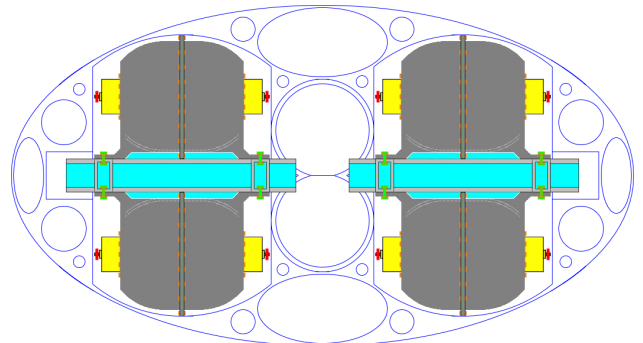
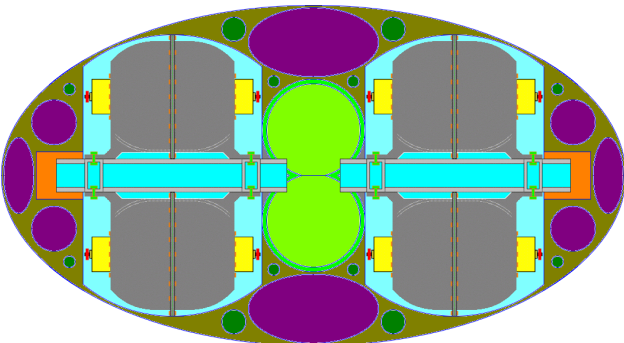
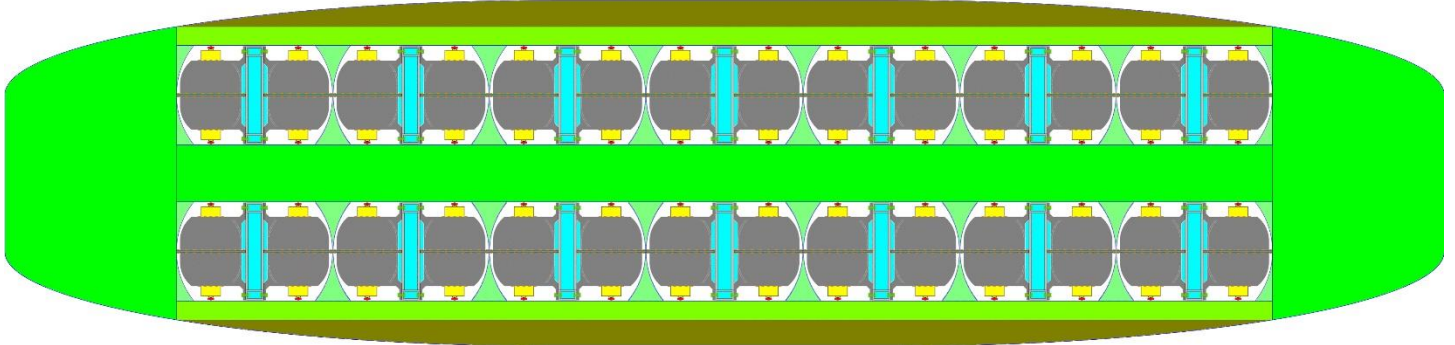
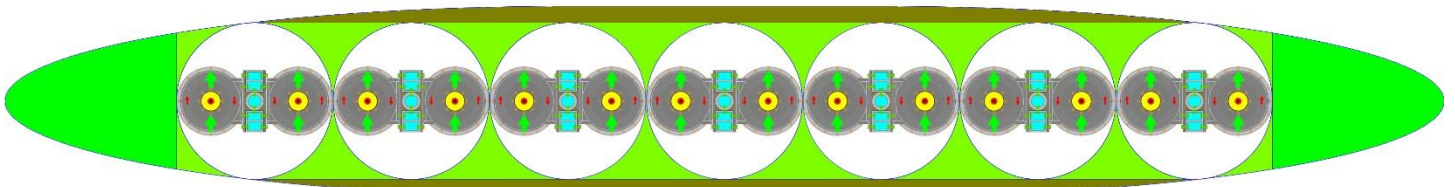
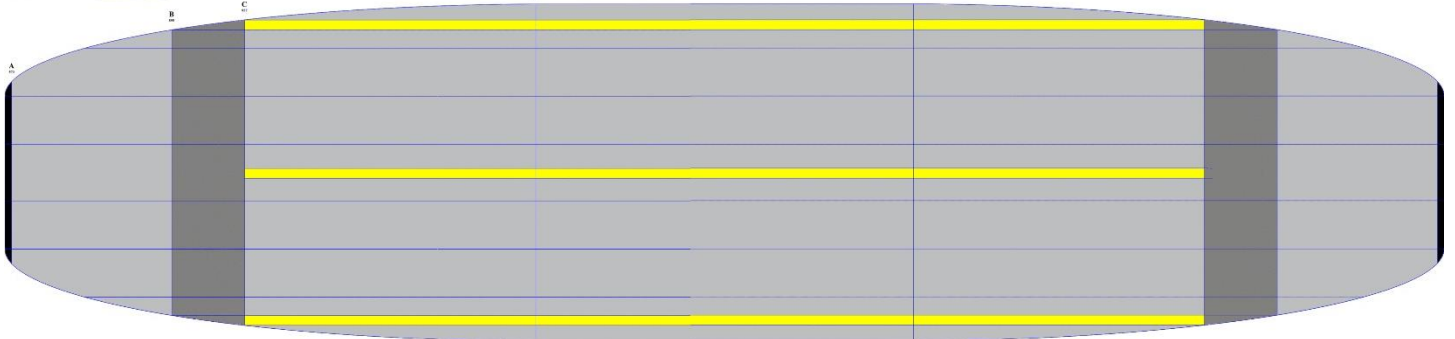
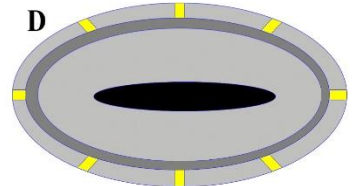
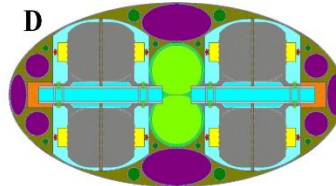
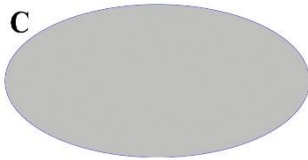
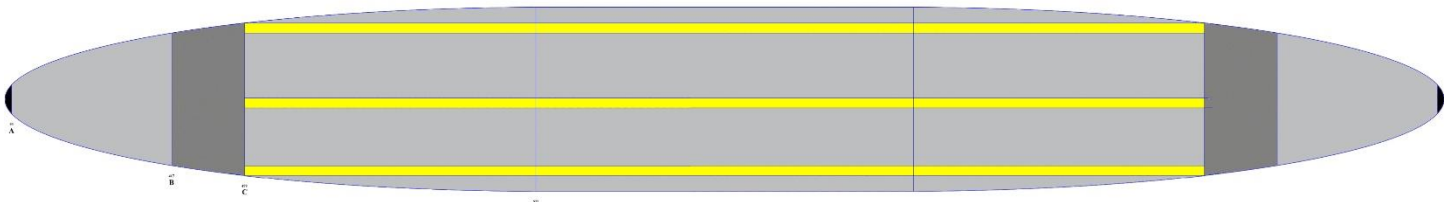

The International Space Agency (ISA), Space Exploration History In The Making

The first historic flight by a private spacecraft into outer space, "Space Ship One" by Aviation Pioneer Mr. Burt Rutan and Scaled Composites, produced a great deal of global interest in Government, Professional, Scientific, Academic, and Public Sectors for Space Exploration.

The well-known Space Scientists and Author, Doctor of Science, Alexander Bolonkin, a writer with Pravda in Russia, recently interviewed Admiral, Rick Dobson, the Founder and present Director (Chairman & CEO) of the International Space Agency (ISA) Organization, which was founded in 1986, incorporated in 1990, is Presently seeking International Treaty & Charter Status, and presently has its Head Quarters located in the United States. A most Nobel and Historic undertaking and effort of our time.

This Russian Pravda News Story By Dr. Alexander Bolonkin Is Found Here:
http://english.pravda.ru/science/19/94/377/14491_space.html

(Russian/English) ISA Scientific Paper Published By Kazan Aviation Institute & Embrey Riddle Is Here:
http://www.kcn.ru/tat_en/science/ans/journals/rasj_cnt/04_2_9.html

24th of October 2004 interview by Dr. Bolonkin with ISA Founder and Director, Mr. Rick R. Dobson, Jr.

Dr. Bolonkin, Question: Honorable Mr. Dobson, can you please briefly tell me about the ISA and how it came to be?

ISA Director Dobson, Answer: Firstly, Thank you Dr. Bolonkin for taking the time to interview me on this most important and historic effort. The International Space Agency (ISA) had its genesis in 1982 when as a senior in high school I wrote a paper on Mankinds journey to Mars and the creation of an International Space Agency. I continued to work on this concept and idea as a personal project until 1986, when while I was serving in United States Naval Aviation at Naval Air Station Oceana in Virginia Beach, Virginia, I had a secret life and conscious changing event that lead me to draft the first formal ISA Concept and Charter and began in earnest to move the ISA vision forward into reality. In 1988 work started on forming the International Space Agency Corporation. In October of 1989 at Cornell University in Ithaca, N.Y. with the support and help of Dr. Norman Scott, Cornell Vice President for Research and Advanced Studies, and the approval and understanding of Dr. Frank Rhodes the President of Cornell University, and with much help and support of numerous Cornell Professors and Students, the ISA Concept and Vision was started in a formal Incorporation Process on September 15th 1989 and was formally approved as a 501c.3 Non-Profit Corporation in New York State on June 5th 1990. Immediately work began on the first historic International Space Agency meeting in Washington, D.C., which indeed took place on May 22nd of 1992 at the Carnegie Endowment For International Peace in Washington, D.C.. Many National Diplomats, National Space Agency Representatives, and Scientific and Aerospace Representatives attended this first historic International Space Agency meeting. Since that first historic ISA meetings in Washington, D.C. in 1992, the ISA has conducted 5 formal, and over 200 private informal, International Diplomatic meetings in Washington, D.C., and the ISA has had a presence at both the 1992 and 2002 World Space Congresses. The International Space Agency has faced much resistance, interference, and misunderstanding over the years due mainly to the fact that people did not fully understand what the ISA was or why it was needed; but also powerful space organizations both Government and Private felt threatened by the Growing ISA Organization and Efforts, as they wrongly perceived ISA as trying to eliminate them. Indeed, to the contrary the ISA is, and has been from its founding, about increasing support and understanding for Human space efforts, activities, and organizations globally. In the last two years support and understanding for the International Space Agency has begun to increase dramatically. Mostly I believe, because National Space Agencies have run them selves into major funding problems and are now seeing ISA as a way to combine limited resources in order to accomplish great things in the next 10 years. Like sending an international manned mission to Mars, an international lunar base, and the International Space Plane Program to build the Earths most advanced electromagnetic assisted space launch system that will for the first time in Human History allow truly routine access to space on a scale and scope never achieved before. Interest in the media and public is rising as well, and

most notably after the first historic flight of a private space plane into orbit, Space Ship One by Burt Rutan and Scaled Composites. I predict that the USA, Russia, Europe, China, Japan, India, Brazil and other Nations will very soon, in the next year or two, formally join the International Space Agency. Once this occurs, there will be a mad dash by commercial and private organizations to get involved and stake their claim in a growing ISA Organization and a global space exploration program and economy which will create millions of new jobs and billions in a new and growing space economy. Not to mention the opening of a whole new human frontier, and the colonization and development of a whole new world, Mars. Very exciting times for the International Space Agency, and indeed, Humanity. If people want to see the present ISA website, it is: <http://www.isa-hq.com>

Dr. Bolonkin, Question: What is the purpose of ISA?

ISA Director Dobson, Answer: In a nut shell, and in simple terms. The purpose of the International Space Agency is to be a Diplomatic, Enabling, Coordinating, Quality and Standards Control, Infrastructure & Capability Building, and Training Organization. The International Space Agency will bring together Global Funding, Resources, Expertise, Knowledge, and Personnel from a wide range of Government, Commercial, Industrial, Scientific, Academic, NGO's & Societies, and Private Organizations, Enterprises, and Ventures. Mainly for large international space programs & projects like an International Space Plane, Advanced Ground Based Launch Systems, Space Stations, Complex Interplanetary Space Craft, Planetary and Moon Exploration, Bases, and Colonization. The International Space Agency would not be involved in small probes, satellites, or commercial projects or ventures.

Dr. Bolonkin, Question: What Countries and scientists took part in your organization?

ISA Director Dobson, Answer: There have been many Countries, just a few of which are, USA, Russia, European Space Agency, China, Japan, India, Canada, Germany, France, Italy, Netherlands, Belgium, Switzerland, United Kingdom, and many others over the years. However, to date there has not yet been any official support for the ISA by any National Government. As I said earlier, this will likely happen in the next year or two if all goes as well, and as hoped. Even major aerospace organizations like Boeing, Fiat, General Electric, Hewlett Packard, and others have taken an active interest and involvement with the ISA Organization. At present a number of scientists have joined the Growing I.S.A. Global Team, and I am sure others will do like wise in the coming days.

Dr. Bolonkin, Question: How can average citizens & people globally take part in and support the ISA Organization & effort?

ISA Director Dobson, Answer: I guess this will be taken by many as a shameless plug, but never the less, the best way to help the ISA at present is to send a donation, grant, or contribution of things like new computers, office equipment, and to contributed professional services & time. Please make any checks payable to: International Space Agency (*please send to ISA the address by certified or registered mail for security.) The International Space Agency is now also forming International Space Agency Societies "National" Globally, which will be overseen by the International Space Agency Foundation "International". If a private citizen anywhere in the world wants to start an ISA Society in their Country, please contact the ISA (*ISA Contact information is provided at end of this interview.)

Dr. Bolonkin, Question: How can people globally take part in the work & efforts of the ISA?

ISA Director Dobson, Answer: They can write to their Government Officials asking them to support and join the International Space Agency. They can write to their Local and National Media asking them to give coverage about the historic ISA Organization and its efforts globally. They can Donate or Contribute to ISA. They can Join or Form an ISA Society in their Country. They can ask their Company or Organization to support ISA, or make a Grant to ISA. They can submit their credentials and formal request to become a Board Member, Officer, Staff, Personnel, or Volunteer of the ISA. They can volunteer to translate the ISA Web Site and Documents into their native language, and establish a native language specific ISA Mirror Web Site in their Country. They can encourage colleagues and professional counterparts globally to support the ISA Organization and Efforts. They can submit ideas and projects for ISA to endeavor to undertake. They can submit papers or articles to be posted

on the ISA News & Information Boards. They can link to the ISA Web Site from their Web Site. And most of all, they can Tell Others About the Historic ISA Organization & Efforts.

Dr. Bolonkin, Question: Director Dobson, what are the main things you hope to see the International Space Agency accomplish in the next 10 years?

ISA Director Dobson, Answer: That is an easy question for me.

- 1) Establish International Treaty and Charter Status with in the next two years, 2005 or 2006.
ESA Diplomatic Letter: http://www.international-space-agency.net/esa_letter_02_16_2004.html
- 2) Undertake International Space Plane Program & Advanced Electromagnetic Assisted Space Launch System
ISP Diplomatic Letter: <http://www.international-space-agency.net/igbsls.html>
- 3) Present International Space Station Program, Transferred to ISA Oversight and Management
*With this, Increased Support for ISS, and an International Orbital Infrastructure Program
- 4) United Nations, Office of Outer Space Affairs, Transferred to ISA Control and Management
*United Nations would focus on world affairs, and the ISA would focus on Space Affairs
*ISA will be independent, not be under any direct U.N. control, but will work closely with U.N.
- 5) Mars / Luna – A Focused International Space Exploration and Colonization Program and Directive
 - Routine Luna Operations & Base in 5 to 7 years
 - * Luna Exploration & Bases will be a part of the Mars Program, not a Separate Program!
 - First Mars Landing by Humans in 7 to 10 years.
 - *Permanent Mars Exploration and Colonization, Main Focus from the very first Mars Landing!
- 6) Access to Earths Orbit, Space, and Luna & Mars will become commonplace and routine.
- 7) Humanity will use the ISA, and this new infinite and vast Space Frontier now with in its grasp, as a means and goal to wean itself off the many many generations of War Based Cultures and Thinking as a means of Growth & Common Survival. The Space Frontier offers a new dimension and pyridine for future human society, culture, and thinking. I hope the young people of this generation discover this truth & fact, and realize it before the ways and thinking of the past bring global destruction and mayhem to the present, leaving human beings to live in caves and struggling just to stay alive, let alone even think about such things as exploring space and settling new worlds! We live in both wondrous times and very dangerous times for humanity. I only hope as a single insignificant human being among billions, could ever even begin to hope for, is that our worlds leaders and wise men globally can stop killing and fighting with each other just long enough to see this wondrous new horizon and opportunity now rising before humanity. The Space Frontier, and a New Planet for Humanity, Mars! The International Space Agency, I believe, and always have since I was small child, is the key and pathway to this New Space Frontier.

Dr. Bolonkin, Question: Director Dobson, if your were to get a phone call from any one person in the World as a result of this interview being read, asking you how they could help! Who would that one person be, and why?

ISA Director Dobson, Answer: Well, let me think? Yes, yes I think it would not be any one person, as that would mean that just one person would have a vested stake in ISA, and its Growth, Development, and Successes. I would love to get a call from any Head of State, say like the President of the United States, President of Russia, President of the European Union or any European Nation, or Leaders from China, Japan, India, and so on. Also, a call from the Head of any National Space Agency like NASA, RSA, ESA, CNSA, JAXA, ISRO, ect. ect. Even a call from the Chairman or CEO of any Aerospace Company like Boeing, RSC Energia, Arianespace, Great Wall Industries, ect. ect. My personal hope though, would be for a call from Neil Armstrong, John Glenn, Burt Rutan, or Arthur C. Clark all personal child hood heroes, and whom I drew my inspiration from when creating the ISA Organization. And Why? That's easy, the International Space Agency needs these people to succeed, and to become and achieve what it can, and must, to be ISA Organization I have envisioned. These people together as a group, through the ISA Organization, can, and will, achieve far more than any one of them, or small few of them, could ever have achieved or even dreamed of achieving. That I think, would be my best hope and goal as a result of this interview and its publication in Pravda in Russia.

Dr. Bolonkin, Question: Director Dobson, what do you hope to gain from working on ISA?

ISA Director Dobson, Answer: To see it succeed! To see it come to life as I have envisioned it! To see my life long sacrifices and dedication to the International Space Agency Organization since 1986 serve the global community of which I am a part, in wondrous and peaceful ways! Most of all to see my Critics, Agitators, and Hecklers all proved wrong, that the ISA is a worthy and just cause, and will succeed; and that their ridicule of me and the tremendous adversity in my life which they have caused over the years, was all worth the many sacrifices and unwavering dedication to the ISA for all these years. I am sure the Wright Brothers, whom I have drawn much inspiration and solace from over the years, did not take kindly to being called Bird Men, (ie: Crazy Men!) and Heckled by Snobbish Elites and Jealous Nay Sayers, who thought their Dream and Vision to build a Heavier Than Air Flying Machine “An Airplane” as a Crazy and Unachievable Endeavor. So much so, that the Numerous Requests by the Wright Brothers to have Media Coverage of the Event was totally ignored and ridiculed as a waste of time, and nobody came that historic day. The pictures we have of that Historic and Famous Event, comes from a photographer who was there only by chance at Kitty Hawk Beach to take pictures of the Life Guards. The Media did not even cover the event in earnest until almost 2 years later, when the Wright Brothers were literally Flying Circles around their Critics and Nay Sayers. In Europe, they refused to even believe, or cover the Wrights accomplishments, until they personally came to France and flew around and gave air rides to people. The odd thing! When the Wright Brothers proved their Dream and Vision, all the former Critics and Nay Sayers then set upon the Wright Brothers like parasites and fleas in an Attempt to Steal and Claim as theirs, the Wright Brothers life’s work, vision, and invention the Airplane. They failed, and again the Wright Brothers prevailed in this adversity. I think the International Space Agency has faced the very same society and human nature problems and intense scrutiny and adversity that the Wright Brothers, and others like Nicola Telsa, Werner von Braun, Tucker and his Car, and many others faced. I hope, and believe, that History will be far more kind and generous to the International Space Agency, and Myself, than the Present, has been.

Dr. Bolonkin, Question: Now how can people contact the ISA?

ISA Director Dobson, Answer: Here is the general contact information for the ISA. I need to let people know that only official items, or official business, in writing and signed or notarized, and sent by certified or registered mail, will receive an official response from the International Space Agency. All other general public inquiries, questions, and comments to the ISA will be replied too, as we have time and resources to do so. Also, for people just wanting to explore ISA Efforts, Information, or interact with other ISA Supporters, please use the Official ISA News Board.

Official ISA Web Site: <http://www.isa-hq.com> **Email:** public-affairs@isa-hq.com
Official ISA News Board: <http://p201.ezboard.com/binternationalspaceagency>
Start An ISA Society, Chapter, Group, or Club: <http://space.meetup.com/5>
ISA Societies & ISA Foundation - Email: foundation@isa-hq.com

ISA Mailing Address: International Space Agency
Post Office Box 541053
Omaha, Nebraska 68154-9053
United States Of America

Public Phone Number: (402) 299-2799 (*Messages Only!)

Dr. Bolonkin, Question: Director Dobson, thank you for your time, and sharing your thoughts and comments about the International Space Agency, and its historic efforts with me today.

ISA Director Dobson, Answer: Dr. Bolonkin, you are welcome, and on behalf of the International Space Agency, the Growing ISA Global Team, and Myself, Thank You, and God Speed! I like wise wish the readership of this interview the same, and ask most humbly as one human being to another, please give your, help, support, and understanding for the Historic International Space Agency Organization & Its Efforts Globally. **Ad-Astra! To The Stars! In Peace For All Mankind!**

2016 Live Radio Address On Husker Radio, North Platte, Nebraska, Given By Admiral, Rick R. Dobson, Jr., Chairman & CEO Of The International Space Agency, ISA.

Firstly, I want to give Academic and Research Credits to, Mr. Les Foran, of Ogallala, Nebraska, who has a Bachelors Degree in Political Sciences with a Minor in Geography. Mr. Foran has a strong personal interest in History, and presently serves on the Board of Directors of Keith County Historical Society, and he was instrumental in the history research and validation of the information provided in today's show. Lieutenant Foran is also an Officer and Member of the Board of Advisors for the International Space Agency. As it is extremely important to me that I always provide to the very best of my ability, truth and hard facts when ever I address the public in mass media, I would like to thank my friend and colleague for the many hours of hard research work he did in preparing me for today's show. I also, want to thank Mr. Marcos Nilla, the host of today's show for inviting me here today, as well as my gratitude to the management and staff of Husker Radio, KODY, to have the great honor of addressing the local listening audience. I hope my presentation today can be educational and interesting to the North Platte and Surrounding Region listening audience of this Radio Station. On today's show, I will address two of the most important figures in Modern Rocketry, and specifically in the American Space Program. They are Robert H. Goddard and Werner von Braun. Then time permitting, I will also cover a little history about the American Manned Space Program.

The first person I want to cover today, is an American Rocket Inventor, and his name is Robert H. Goddard. He was Born on the 5th of October in 1883 in Worchester, Massachusetts, and he Died at the age of 62 on the 10th of August in 1945.

In 1926, At the age of 43, Goddard was inventing and launching liquid rockets that used gasoline and liquid oxygen on his Aunts Farm in Auburn, Massachusetts, which angered and scared local residents, and many complaints where made to local officials. One such complaint by a local resident is said to have accused Goddard of practicing some type of magic or witchcraft with his loud roaring machines of fire. Anyway. A good movie I would highly recommend to your listeners interested in this topic to look for, is a movie called "The Rocket Boys" re-released as "October Sky". It is a family friendly movie, and is well written and has extremely good acting and highly developed story line based on real people and events. It shows the golden years of America, and the dreams of its youth.

First of Goddard's test Rockets was Goddard 1, and in 1926 on March 16th the single stage Liquid Rocket reached an amazing 41 feet in altitude. On April 3rd 1926 it reached an even more amazing 49 Feet in altitude.

Another of his early liquid rockets, Godard 3, on Dec 26, 1928 made a flight of 16 Feet before its engine exploded in fire and deadly shrapnel. For every failure in life, we are always only one step closer to success, and to those who give up on the first few failures, will likely never have a great success in their life. Howard Hughes, the great American Aviator and Aviation Inventor, used to quote a famous saying by Russian Inventor Skicorski who left Russia and came to the safety and freedom of America, and was one of the main inventors of the helicopter. An excited Skicorsky was quoted by a news paper reporter as he climbed out of one of his early helicopter prototypes that had just had a catastrophic crash, which could have well killed him, and as he pulled himself free of the wrecked helicopter and with a big smile, walked over to the press, and said these famous words. "**Success is nothing but Failure turned inside out**" That very same prototype helicopter was later repaired and re-flown by Skicorsky and others to break numerous aviation records, and set the rotary wing aircraft into the history books. Howard Hughes and Hughes Aviation/Helicopter inspired by the work of Skicorski, later went on to make some of the most advanced Helicopters in the world.

On July 17th 1929 Godard finally received his first Mass Media Attention when his liquid fueled rocket reached a stunning altitude of 90 feet before exploding into a ball of fire and debris.

In 1929 the metal alloys were not perfected for high heat and high pressure conditions found in liquid fuel rocket engines today, and composite materials were not even thought of, or invented yet. The use of high energy explosive liquid fuels were new and in its infancy in 1929. Many inventors like Goddard, the Wright Brothers, Nicole Tesla, and many other inventors have faced scorn, ridicule, and down right malicious treatment by society, because they dared to dream, and tried to accomplish that which had never been done before. Had Society not had these brave and daring inventors with vision, passion, and curiosity, most of what we take for granted today in our modern world, would not even exist. This is something people need to think about before they accuse a rocket inventor like Goddard of practicing witchcraft with fiery evil contraptions, or maliciously calling great men like the Wright Brother's, Bird Men running around flapping their arms and trying to fly like Birds, or so easily with out care or guilt force great men like Nicole Tesla to dig sewer ditches in the streets because of the gossip, hearsay, and lies spread around by greedy and jealous naysayers and backwards superstitious people. Many of histories most gifted and famous inventors who have made the most revolutionary, important, and historic accomplishments in human history have faced this sad plight and affliction of Society.

Famous American Aviator, Charles Lindberg, who had watched the work of Goddard with much curiosity and interest, in late 1929, try's to find financing for Goddard's novel, and important historic rocket research.

Funding is secured by Charles Lindberg in the Spring of 1930 for Goddard, with a 4 year grant by Daniel Guggenheim in the Sum of \$100,000.

Then in the Summer of 1930, Goddard moves to the remote Roswell New Mexico Desert, far from nosey and prying eyes and the endless stream of gossip and nay sayers.

The first rocket tested by Goddard in the New Mexico Desert is Goddard 4 on Dec 30, 1930, and in a giant leap forward, reaching an altitude of 2,000 feet. The increased funding and resources made a big difference in the successful advancement of the development and testing of his liquid fueled rockets.

In the Spring of 1932 Goddard had a frustrating loss of funding at a critical stage in his research and had to leave his Roswell Dessert rocket testing site and went to teach at Clark University, in Worcester, Massachusetts.

A demonstration Test Flight was done on April 19, 1932 and reached an altitude of 135 feet.

In the Fall of 1934 Funding by Daniel Guggenheim was Restored, and Goddard returned to the remote Roswell New Mexico dessert test site to continue his research and development of liquid fueled rockets.

His first rocket designed and built when he returned to Roswell, New Mexico, was the Single Stage A Series, and two notable flights where, on Feb 16, 1935 which achieved 650 feet, and on March 8, 1935 which achieved 1,000 feet.

A career best for Goddard was achieved on March 26, 1937 when an altitude of between 8,000 to 9,000 feet was achieved.

One of the Last Flights conducted by Rocket Inventor Robert H. Goddard's long research and development career, was the 36-10 Series of Liquid Rocket Prototypes in 1941.

Here are a few note worthy and interesting facts about Robert H. Goddard's amazing life and career.

There was indeed Espionage against Robert Goddard during his rocket development career. In 1935 a female Russian spy imbedded in the U.S. Navy Department of the Bureau of Aeronautics, disclosed info about his rocket launch activities in 1933 to the Russian Military. In 1936, two German Spies, Friedrich Boetticher a Military Attaché from Germany, and Gufeav Guellich a German Spy in Roswell, New Mexico disclosed information to the German Military about Goddard's rocket research and activities. The Germans likely had little real interest in Goddard's work, as they where many years ahead of Goddard and the Americans with their Secret Rocket Programs, and likely where just monitoring his progress to see if he was of any real threat to their ongoing secret efforts in Germany.

In 1942 Goddard was appointed as Director of Research at U.S. Navy Dept of the Bureau of Aeronautics.

From 1942 to 1945 he worked on the Jet Assisted Take Off Program, or better known as the JATO Program, and this program was started to develop the ability to assist Aircraft and Heavy Bombers to take off on very short runways, and used in take off tests on early aircraft carries.

From 1943 to 1945 Goddard was a Consulting Engineer at Cutis Wright in Caldwell New Jersey

From 1944 to 1945 he was the Director of the American Rocket Society

In 1945, just before Goddard died, he was invited as a VIP of the United States Navy Department to inspect a captured German V-2 Rocket at the Naval Academy in Annapolis Maryland. In the end of this great Americans life as a Rocket Inventor, Researcher, and Scientist, he saw first hand that his rockets, which at the time were the pinnacle of American Rocketry in 1945, had reached only a maximum of 8,000 to 9,000 feet, was massively overshadowed by the secret advanced German V-2's, which were already routinely reaching sub-orbital heights of 2 miles in altitude, or much more.

The death of American Inventor Robert H. Goddard on August 10th 1945, now brings us to the second most influential person in the History of Modern Rocketry, and was indeed the very man who invented and developed that very V-2 rocket which Goddard had viewed at the Naval Academy in Annapolis, Maryland just before his death.

This second man, who was captured along with nearly his entire German V-2 Group, would later become the first Director of the newly formed NASA, Marshal Space Flight Center in Huntsville, Alabama, and was indeed the man who designed the Apollo Saturn 5 Rockets, and Lead the American NASA Teams that put the first Americans, and Humans from Earth, onto another Planetary Body, the Earths Moon.

His name was Werner von Braun, and he is known as the father of modern rocketry. On July 20th, 1969, 24 years after the Death of American Rocket Inventor Robert H. Goddard, and the Capture of German Rocket Scientist Werner von Braun by the Americans, the American Apollo Saturn 5 Rockets put Mankind on the Moon. In only 24 years, Humans went from 9,000 feet and 2 Miles above the Earths surface in 1945, to the Moon's Surface from the Earths Surface and Back in 1969.

Today it has now been 47 Years since Mankind walked on the Moon, which is now more than twice the time it took Humanity to go from 9,000 feet and 2 Miles above the Earth, and from Earth to the Moon and Back, and the American, and Global Space Community, has yet to surpass this historic accomplishment. Why? Humans should already have Bases on the Moon, and Human Missions and Bases on Mars and other locations in our Solar System by this present time in 2015, but sadly it has not happened yet? The underlying reasons for this must be seriously addressed, if Humanity is to survive in this present reality of Energy, Nuclear, Biological, and Chemical Weapons of Massive Destruction Potential. Which today are capable of destroying every living thing on this Planet Earth.

On the gold plaque commissioned by NASA at the Saturn 5 Launch Site and another placed on the Moon, the Words AD-ASTRA, We Came In Peace For All Mankind, is engraved. The Word AD-ASTRA means, To The Stars. The official motto of the International Space Agency founded in 1986 and Incorporated in 1990 is, AD-ASTRA! To The Stars! In Peace For All Mankind!

The second person I will cover now, is a German Rocket Scientist, who later was to become an American Citizen, and his name is Werner von Braun. He was Born on the 23rd of March, 1912, in Wirsitz, Prussia which was then part of Germany, and is Today the City of Wyrztsk, in Poland, and he Died at the age of 65 on the 16th of June, 1977, in Alexandria, Virginia.

One of the notable projects that Werner von Braun worked on while he was in Germany, was the Civilian A-4 Rocket Research Program, that later was taken over by the German Airforce and renamed the V-2 Rocket

Program. In 1934 the A-4 Rocket Program made two notable flights of 2.2 kilometers in altitude and 3.5 kilometers, which is 2 miles in altitude. At the same time in 1934 the Americans, and Robert Goddard, had only achieved altitudes of around 2,000 feet.

On the 22nd Dec 1942, German Chancellor Adolf Hitler approved the A-4 Program to be taken over by the German Airforce as the Military V-2 Rocket Program, and was so happy at the film of the first launching of a V-2 test launch, that he advanced the young Rocket Scientist, Werner von Braun to the full status of Professor, who was at the time 31 years old.

The first combat use of the German Airforce V-2 rocket was launched against London, England on the 7th of December 1944, and was amazingly only 21 months after the German Airforce V-2 Rocket Program had been commissioned by German Chancellor, Adolf Hitler.

After Germany surrendered, and the American Forces captured Werner von Braun and nearly his entire V-2 Rocket Group, on the 20th of June, 1945, the American Secretary of State, Edward Steteinius, Jr., approved Werner von Braun and his V-2 rocket group to come to the United States.

On the 20th of August, 1945, Werner Von Braun's V-2 Rocket Group was sent to New Castle U.S. Army Air Field, in Wilmington, Delaware, and then later in 1945 where sent to Aberdeen, Maryland.

In 1946 Werner von Braun and members of the V-2 Group where sent to Fort Bliss, in El Paso, Texas to work on the Hermes Project, which basically was captured and refurbished German Airforce V-2's rockets being secretly launched and tested at the White Sands Proving Grounds.

In 1950 Werner von Braun and some of his V-2 Group was transferred to Huntsville, Alabama, and from 1950 to 1956 they worked at the U.S. Army Redstone Arsenal on the Redstone Ballistic Rocket Program. During that time, Werner von Braun was appointed as the Director of Development Operations Division of the U.S. Army Ballistic Missile Agency.

In 1950's, Werner von Braun was the most vocal and supportive advocate for the American Civilian Space Program, and a number of great educational movies by Werner von Braun were personally commissioned and funded by Walt Disney, who at the time saw Space Exploration as a bright future for Americas young people.

The National Aeronautics and Space Administration, or better known as just NASA, was officially created on the 29th of July 1958, and was the merging of NACA, Jet Propulsion Labs, and elements of the U.S. Army Ballistic Missile Agency.

NASA was founded to lead the American Civilian Space and Aviation Efforts and Activities, separately from the Military Space and Aviation Efforts and Activities. This as it was hoped that International Space and Aviation activities globally could be nurtured in the post WW2 era creating jobs, new industries, and new economic advances, and that American Leadership could play a major part in this.

In 1960, Werner von Braun was transferred to the newly formed NASA Marshal Space Flight Center located in Huntsville, Alabama. Von Braun served as the Director of NASA, Marshal Space Flight Center from July 1960 to February 1970. Werner von Braun was NOT a NAZI, and even today these lies are propogated by ignorant and spiteful people. NASA and Americas Space Program has also suffered from these purposeful lies.

Later NASA programs which Werner von Braun was involved in were the Mercury (Jupiter C) Program started in 1958,, which was based on a modified Redstone Ballistic Rocket that was non-man rated when it successfully launched the Explorer 1 Satellite on the 31st of Jan, 1958, and for the first time putting an American spacecraft in a Stable Earths Orbit. The Russians had already beaten the Americans to Earths Orbit with the launch of a Soyuz Rocket carrying the Sputnik Satellite successfully into a Stable Earth Orbit. The later fully Man-Rated Mercury Program Ended in May of 1963, and had used both the Atlas D "LV3B" Ballistic Missile, and Redstone Ballistic Missile to carry the One Person Mercury Capsules into Stable Earth Orbits.

The follow on to the one man space capsule Mercury Program, was the two man space capsule Gemini Program, and was started in 1961 and ended in 1966, and used converted Titan 2, GLV, Intercontinental Ballistic Missiles. This program was to train and prepare the American Astronauts and NASA personnel for the planned 3 person capsule of the Saturn 5 Rocket, for Apollo Moon Program

At the Direct Orders of the American President John F. Kennedy, and as a follow up to his famous speech that he would send American Astronauts to the Moon and bring them safely back with in ten years. The NASA Apollo Program that developed the Saturn 5 Moon Rocket was started on the 10th of January, 1961, and the development of the Saturn 5 Moon Rocket was started and based at NASA, Cape Canaveral, in Florida.

About seven years later, on the 9th of November, 1967 the very first Saturn 5 Moon Rocket launched from NASA, Cape Canaveral, in Florida, for an operational test flight in Earths Orbit.

3rd Saturn 5 vehicle launched, was Apollo 8, and in December of 1968, the fully crewed Saturn 5 Rocket with 3 American Astronauts on board, was launched from NASA Cape Canaveral, and made the trip to the moon, orbited the Moon, but did not send a manned lander to the surface of the moon, then returned to Earth.

Then on July 20th, 1969, the Famous words of American NASA Astronaut Neil Armstrong as he stepped off the ladder of the two man Eagle Moon Lander onto the Moons Surface, where transmitted from Tranquility Base where the Lander had just landed on the surface of Earths Moon, and was heard by hundreds of millions of people on Earth. "This Is One Small Step For Man, And One Giant Leap For Mankind". Neil Armstrong was justifiably very nervous when he said those now famous and historic words, as he was now the first human to step onto another planetary body other than Earth, and was knowingly speaking to nearly all the Citizens of the whole Earth. He was actually supposed to say: "This Is One Small Step For A Man, And One Giant Leap For Mankind". So Neil Armstrong left out one little "A" in this historic transmission to his fellow Earthlings from the Moons Surface, who knew? This was the achieving moment of the Apollo Moon Rocket Program, and the stunning success of the Saturn 5 Moon Rocket designed by American Rocket Scientist, Werner von Braun.

In 1970, the NASA Leadership asks Werner von Braun to move to Washington, D.C., and to head the Strategic Planning for the whole agency.

In 1972, Werner von Braun retires from NASA, and goes to work for Fairchild Industries, in German Town Maryland, and worked there until his death at the age of 65, on the 16th of June, 1977, in Alexandria, Virginia.

On the 17th of July, 1975, the USSR, Soviet Soyuz Capsule and American Apollo Capsule link up in Earths Orbit, and the Astronauts and Cosmonauts of both Countries meet in the Link Up Module connecting the American and Soviet Space Craft in Earths Orbit, and shake hands and exchange chocolate and gifts. This brought the second hope of the American President John F. Kennedy's goal for NASA and the Apollo Space Program into full focus and success, and that was that the Global Space Effort should be a Civilian and Peaceful Endeavor between the Nations and Peoples of Planet Earth.

The American Space Transportation System (STS Program), better known simply as the American Space Shuttle Program, was started and commissioned in 1972, and was based on the advice and urging of Werner von Braun, that for any American Manned Space Program of scale, like building rotational gravity space stations in Earths orbit, Manned Lunar Bases, or Manned Missions and Bases on Mars, America must design, build, and operate a fully reusable space vehicle that would carry cargo, equipment, and crews from Earths Surface into Earths Orbit. The original designs and specifications by Werner von Braun that a form of Assisted Launch Space Plane System, that would be a Single Stage To Orbit "SSTO" Vehicle be designed and built, was sadly ignored, and due to nasty and malicious Bolshevik Marxist ideologies and politics creeping into and taking hold of the American Government and Society in the 1960's and 1970's, the Space Shuttle System that America got stuck with, was not what Werner von Braun proposed as a follow on to the Expendable Rockets of the Apollo Era. The Assisted Launch Concept was used by the Germans in WW2 with their V-1 Program, and most notably used in Naval Aviation on Aircraft Carriers "Aircraft Catapult System". The Aircraft Carriers used a high pressure steam piston system to accelerate the aircraft off the Carrier Flight Deck. Today the United States newest Aircraft Carrier uses

Electromagnetic Catapults. In WW2 the Germans had the Silver Bird Space Plane Program, which used a 3 mile launch track and rocket sled to accelerate the Space Plane into Earth Orbit. The Fully Reusable Space Launch System which Werner von Braun advised NASA and DOD to build after the Apollo Program, was an Assisted Launched SSTO/RLV Space Plane. The Space Shuttle Program that America got stuck with, was basically an Expendable Ballistic Missile with a Space Glider strapped to it. The fully reusable “SSTO” space plane assisted launch system that Werner von Braun proposed in the late 1950’s and into the 1960’s, is today fully embedded into the International Space Agency, International Space Plane Program, as are the vision, hopes, and values that the late President John F Kennedy had for Mankind’s Space Exploration Endeavors, and that it would be a Civilian and Peaceful Endeavor by the many Nations and Peoples of Earth. And thus the official motto of the International Space Agency since its founding in 1986, has been. AD-ASTRA! To The Stars! In Peace For All Mankind!

The first fully operational prototype NASA STS Shuttle designed and built to test its aerodynamics and avionics systems at full scale, was the Space Shuttle Enterprise, and was first drop tested on the 18th of February, 1977 from a specially designed 747 Jumbo Jet. This NASA Aircraft carried the Shuttle Enterprise on the top of its fuselage, to high altitudes, and then released the Shuttle Enterprise to glide to its landing site. This specially designed NASA 747 Jumbo Jet, was later used by NASA to transport the Space Shuttles from their landing sites, back to NASA Cape Canaveral launch facilities in Florida. Later on in the NASA STS Program, a new landing runway actually located at NASA Cape Canaveral, Florida went operational, and the shuttles where then directly landing at the launch site, and so the NASA 747 Carrier Aircraft was no longer needed.

The First Operational Orbital Launch of the NASA STS Shuttle Program, was the Shuttle Columbia STS “1”, and was launched from NASA Cape Canaveral on the 12th of April, 1981.

The Last Operational Flight of the NASA STS Program, was the Shuttle Atlantis, STS Flight “135”, and was launched from NASA Cape Canaveral on the 21st of July, 2011.

From April 1981 to July of 2011, a span of about 30 years, the American NASA STS Program had a total of 135 Shuttle Launches, that was basically an average of 2.7 Shuttle Launches per month, with a total of 133 successful launches and missions, and sadly two catastrophic losses of the vehicles and crews. The first Shuttle accident happened on the launch of the Challenger on the 28th of January 1986, and the second Shuttle accident happened on the Re-Entry of the Columbia on the 1st of February 2003.

On the 25th of January 1984, the American President Ronald Reagan ordered the commissioning of the American Space Station Program, and in 1985 NASA put forward a design for the American Space Station Program, called originally, Space Station Freedom. The American Space Station Program was later gutted, down sized, and politically sabotaged, and was so mauled into such a feeble mess of a program and lacking any real funding or national support, NASA in a desperate effort, reached out to the Russian Space Agency, European Space Agency, Japanese Space Agency, Canadian Space Agency, and the Brazilian Space Agency, to keep the Space Station Freedom Vision and Dream alive, and through international agreements and joint funding, the American Space Station Freedom, had its rebirth as the International Space Station, ISS. This massive International, Joint Multi-National, Space Station Complex is presently in Earths Orbit Today.

The American NASA Space Station Freedom, Later Re-Designed and Re-Named the International Space Station (ISS), had its first operational element and module launched into orbit by Russia on a Russian Energia Heavy Lift Rocket, on the 20th of November 1998, and this first ISS element launched into orbit was built and funded totally by the Russians, and was their contribution to the ISS Joint Multi-National Space Station and International Space Station Treaty Agreement. In May of 2011, the last ISS element was taken into Earths Orbit by U.S. Space Shuttle Endeavor. To those who want to look for the International Space Station as it passes in orbit over their area, can look up the ISS Orbital Information on the NASA Site or can Google it. The International Space Station is so large, it can be seen with the naked eye at night time, as it orbits over head.

INTERNATIONAL SPACE AGENCY (ISA)

INTERNATIONAL SPACE ACADEMY HUMAN SPACE FLIGHT (ISFO) CHARTER



PROJECT NAME: **HB&CH-DLDSF** **HUMAN BIOLOGY & CREW** **HEALTH DURING LONG** **DURATION SPACE FLIGHT**

HG&CH-DLDSF PROPOSAL DATE: 17 October 2013

HG&CH-DLDSF PROJECT INITIATORS / AUTHORS:

Mr. Martin Cabaniss, United States
Director, International Space Academy

Mr. Abhishek Kumar Sinha, India
Assistant Director, International Space Academy

HG&CH-DLDSF SPONCORS:

International Space Agency (ISA)

International Space Academy (ISA)

(ISA) International Space Flight & Operations (ISFO)

BACKGROUND: International Space Agency was Founded in 1986 by Admiral, Rick Dobson, Jr., a Veteran of U.S. Naval Aviation, and established and incorporated ISA in 1990 in Ithaca, New York State, USA, as a non-profit corporation for the purpose of advancing Man's visionary quest to journey to other planets and to the stars. The International Space Academy and the International Space Flight & Operations (ISFO) Program is part of International Space Agency (ISA), which supports research on Human Space Flight and its complications. It will support research on "Effects of Microgravity on Astronauts" and "Effects of Galactic Cosmic Radiation (GCR) on Astronauts". It will also discuss feasible solutions to countermeasure the effects of Space Flight on Astronauts. This is critical level research, on which the safety & health of future ISA Space Crews & Personnel will greatly depend on, and will be conducted by the ISA ISFO Program and International Space Academy.

HG&CH-DLDSF OBJECTIVES:

- Research on **Effect of Microgravity on Bone Density**
- Research on **Effect of Microgravity on Muscles**
- Research on **Fluid Shifts due to Microgravity**
- Research on **Cardiovascular Deconditioning in Microgravity**
- Research on **Effect of Microgravity on Inner Ear and Balance System.**
- Research on **Immune Problem in Space**
- Research on **Digestive Organs during Long Spaceflight**
- Research on **Disruption of Vision**
- Research on **Disruption of Taste**
- Research on **Space Motion Sickness**
- Research on **Microbial Contamination of Spacecraft**
- Research on **Adaptation of the Central Nervous System to Spaceflight**
- Research on **Chromosome Aberration Analysis in Astronauts**
- Research on **Evaluating Shielding Approaches to Reduce Space Radiation Cancer Risks, etc.**

HG&CH-DLDSF PURPOSE:

- In microgravity, astronauts no longer walk to get to different parts of the spacecraft, they float. This means that the bones in the lower part of the body that typically bear weight – the legs, hips and spine – experience a significant decrease in load bearing. This reduction leads to bone breakdown and a release of calcium, which is reabsorbed by the body, leaving the bone more brittle and weak. The release of calcium can also increase the risk of kidney stone formation and bone fractures.
- Extended spaceflight results in less load on the leg muscles and on the back’s muscles used for posture. As a result, the muscles can begin to weaken or atrophy, and this could lead to fall-related injuries and accidents during exploration missions.
- In space, the body no longer experiences the downward pull of gravity that distributes the blood and other body fluids to the lower part of the body, especially the legs. The fluids are redistributed to the upper part of the body and away from the lower extremities. While in space, astronauts often have a puffy face due to this fluid shift and legs that are smaller in circumference.
- Although the cardiovascular system generally functions well in space, the heart doesn’t have to work as hard in the microgravity environment. Over time, this could lead to deconditioning and a decrease in the size of the heart. There is also a concern that space radiation may affect endothelial cells, the lining of blood vessels, which might initiate or accelerate coronary heart disease.
- Astronauts get a bit taller in space. On Earth, the disks between the vertebrae of the spinal column are slightly compressed due to gravity. In space, that compression is no longer present causing the disks to expand. The result: the spine lengthens, and the astronaut is taller. One possible side effect is back pain that may be associated with the lengthening of the spine.
- On Earth, a complex, integrated set of neural circuits allows humans to maintain balance, stabilize vision and understand body orientation in terms of location and direction. The brain receives and interprets information from numerous sense organs, particularly in the eyes, inner ear vestibular organs and the deep senses from muscles and joints. In space, this pattern of information is changed. The inner ear, which is sensitive to gravity, no longer functions as designed. Early in the mission, astronauts can experience disorientation, space motion sickness and a loss of sense of direction. Upon return to Earth, they must readjust to Earth’s gravity and can experience problems standing up, stabilizing their gaze, walking and turning. These disturbances are more profound as the length of microgravity exposure increases. The changes can impact operational activities including approach and landing, docking, remote manipulation, extravehicular activity and post-landing normal and emergency egress.
- **Many factors** – the loss of a 24-hour day/light cycle, a confined environment and work demands – can impact an astronaut’s ability to work well in space. In addition, exploration crews will have to shift their “body clocks” from the Earth day/night cycle to that of their destination. Scientists hope to help the crew increase their alertness and reduce performance errors through improvements to spacecraft lighting, sleep schedules and the scheduling of work shifts.

HG&CH-DLDSF SCOPE:

- The scope of the project will include ISA members who research on above mentioned objectives by 2014.
- The project will include Research Report with plain text, images, scientific notation and data.
- The project will include report created in MS Word and LaTeX.
- The number of ISA members participating in the project will depend on the number of willing members and researchers to participate.
- Research Reports are based on data collected from various space agencies and research journals.
- A database is maintained for the Research Report and will be published in various journals under ISA Research.

HG&CH-DLDSF DELIVERABLES:

- Between 2 and 4 electronic report in PDF format will be available for ISA.
- Research Journals will be available to ISA member upon request.
- Research study will be updated in Social Networking Websites
- Newsletter will be available to ISA which contain latest study on Human Spaceflight.

HG&CH-DLDSF PRIORITY:

- The objectives should be achieved by 2014
- Every month Newsletter will be available to ISA.
- The research data is based on authentic sources like Space Agencies and various journals. The Wikipedia article is not included in research report.
- The reference should be mentioned in each and every research.

HG&CH-DLDSF PROPOSED PROJECT PLAN (MONTH / YEAR)

- Nov. 2013.
- Research on Effect of Microgravity on Bone Density
- Newsletter on Effect of Microgravity on Bone Density

HG&CH-DLDSF POTENTIAL ISSUES or CONSTRIANTS

- Project not communicated clearly to researcher or ISA member
- Too few participants in the project
- Data privacy constraints
- Lack of committed resources (staff time)

HG&CH-DLDSF RISK MANAGAMENT

- Clear and timely communication strategy
- Personal invitation to potential researchers and ISA memeber
- Hire extra expertise if necessary
- Hire extra personnel

HG&CH-DLDSF COMPLETION CRITERIA

- Between 2 to 4 electronic research report in the ISA Repository
- Newsletter in every month
- Research paper in journals
- Theses submission guidelines fully revised by ISA .
- The final decision is made by ISA.



Founded in 1986
Incorporated in 1990

INTERNATIONAL SPACE AGENCY - I. S. A. INTERNATIONAL SPACE ADMINISTRATION

MAILING ADDRESS: Post Office Box 541053, Omaha, Nebraska, 68154, in the United States of America
Washington, D.C., Diplomatic Offices: (202) 917-0209 **Omaha, Nebraska, Administrative Offices:** (402) 299-2799
Denver, Colorado, Advanced Space Propulsion & Technology Research & Development Center: (303) 201-0148
Website: www.international-space-agency.us **Email:** public-affairs@international-space-agency.us

To: International Space Agency Board of Directors
International Space Agency Board of Advisors
International Space Agency Officers -&- Staff

NOTICE: Classified, Private -&- Confidential Information
For Official Use Only, Not For Public Release
(Page 1 of 1) Date: 12th of April, 2017

From: Admiral, Rick R. Dobson, Jr.
Founder, Chairman of the Board of Directors, Chief Executive Officer
International Space Agency, I.S.A., International Space Administration

Subject: 12th of April, 2017 Update From The International Space Agency Founder

Dear Colleagues -&- Friends, Respectfully,

I write this communication with the knowledge, that over 30 years ago "May of 1986" while I was a young man serving in Naval Aviation stationed at Naval Air Station Oceana in Virginia Beach, Virginia, the International Space Agency came to me while I was sitting on the dock in my back yard at 1:00 AM looking out over the bay and the vast oceans of the seas and stars before me that night. The depth and importance of the events of this evening goes far beyond what I can speak of publicly, but some very close to me know the full truth of the meaning of my words, and the source of the inspiration of this life changing evening and event in my life, and indeed for the hopeful future of mankind of Planet Earth. This led to the 30+ year quest I have been on with the International Space Agency endeavor.

I am only but one of many billions of self aware beings on this tiny planet floating through the infinite vastness of creation, in a collective and unified mind of reality we call the Universe. Our Earth, sadly, has been plagued with perpetual evil and blood shed between, and by, human species on Planet Earth for many thousands of years now. We of Planet Earth have however, now reached a cross roads of great historic importance and dire implications for ALL life on this tiny Planet we call Earth. Through the Environment and Art of War, Killing, Deception, and Mind Control, utilized by the Species of Humanoids of Earth over the last several thousand years for survival and domination, have developed levels of Science and Technology that has now reached an apex that will surely destroy ALL life on this Planet Earth if this vindictive and evil spirit of the Species of Humanoids on Planet Earth is not immediately brought under control. We are now faced with changing and adapting to a new reality of collective right action, or we will face total destruction. The level of Science and Technology now achieved, has made War Culture no longer an option. With the development of Fission, Fusion, Chemical, Biological, Energy Beam, and Mind Altering Sciences and Technologies that have been Weaponized in the last 100 years, and the expansion of Humanoid Species populations and civilizations rapid growth, friction, and collisions over the surface of Planet Earth and the increasing and intensifying competition for the use and control for the ever dwindling natural and biological resources of Planet Earth, a Catastrophic Total Destruction of ALL Life and Civilization is now imminent. Turning our energies from inward self-destructive nature over a finite Earth to an outward peaceful exploration nature of an Infinite Universe is the cross roads we now face. Change our ways or perish, as simple as that. Those minds who have led us to this day, are unable to lead us to the new day. A new generation of minds are here now, and must be aloud to led us forward, for the implications of failure to have the wisdom to understand this, will have catastrophic results. These new minds must be protected high above and far out of reach from the demented and deranged minds now running out of control on this Planet Earth. The reality that we are not alone in this Universe is a new reality that must also be understood soon, for the failure to do so can also have dire implications. We either turn in on ourselves in a finite vicious last spurt of suicidal self-destruction, or turn outward peacefully into an infinite frontier of exploration and hope. Time Is Very Short!, The Apex Moment Has Arrived! The Decision To Survive Or Self-Destruct Must Now Be Made. For Me, I Chose, Ad-Astra! To The Stars! In Peace For All Mankind!

As a note, after the events of 2013, and the perpetual targeting of me, my works, and my supporters since 1990, I will no longer disclose my Board Members, Officers, or Supporters Publicly or Internally unless there is a specific need to know. That ever present evil element of humans addressed above, has plagued me ever since the International Space Agency and our Endeavors where formally incorporated in 1990. The International Space Agency represents the New Day and the New Generation of Minds, and there are very evil, demented, and deranged humans that are bent on not only psychotic sociopathic self destructive nature, but will if aloud destroy us all with no remorse or feeling at all. And know this clearly, the International Space Agency is NOT a World Space Agency and is in no way part of the United Nations. It is a Multi-National Space Agency of Governmental, Commercial, Scientific, Academic, and Private Entities and Persons Capable, Able, and Willing to be peaceful, productive, and meaningful members to the International Space Agency Charter, Organization, and Endeavors. Not all species of humanoids of Planet Earth are ready, able, or willing, let alone even capable of understanding, Ad-Astra! To The Stars! In Peace For All Mankind! As the waters rise to cleanse the evil and bring in the light of the new day, sadly, there will be many claw marks on the hull of the Ark. Those that have ears to hear, eyes to see, and a spirit of wisdom to embrace the light of the new day ahead will repent of their old natures and embrace the new nature of a new age of a New Heaven and a New Earth. Those who truly understand Ad-Astra! To The Stars! In Peace For All Mankind! Are those who will bring in the true new age, and will see the light of the new day for they and their future generations. Many will be consumed by the rising waters and will be no more.

Humbly In Your Service, Truly, I Am,
Admiral, Rick Redigo "White" Dobson "Gallagher"
Founder, Chairman, CEO
International Space Agency, I.S.A.
International Space Administration



Mankinds Next Great Frontier

Is Consciousness And Awareness Of Its Place In The Universe

By: Admiral, Rick R. Dobson, Jr., Founder, International Space Agency

Mailing Address: P.O. Box 541053, Omaha, Nebraska, 68154

Omaha Nebraska: (402) 299-2799 Washington, D.C.: (202) 917-0209

International Space Agency, I.S.A.: Name, Public Identity, Logo, Emblem: Are: U.S.A. Registered ®: Trademark ™ Copyrights © 1986-2019, All Rights Are Reserved

INTERNATIONAL SPACE AGENCY - “ISA”

~ PURPOSE ~

The **International Space Agency “ISA” International Space Administration**; was formed to act as an “Enabler” and “Conduit” for Peaceful, Cooperative, Collaborative, and Joint Global “International” Space Activities by the Major Space Nations, Developing Space Nations, and In General the Global Space Community; to Plan, Develop, Promote, Encourage, and Increase Overall Cooperation in the Area of Government, Commercial, Scientific, Academic, Private Cooperative Global Space Efforts and Activities, for Strictly Peaceful, Non-Military, Purposes, and to the Common Benefit of the Peoples of Earth.

~ BACKGROUND ~

The **International Space Agency “ISA”**, was Founded in 1986, and Incorporated in New York State as a Scientific & Aerospace – Research & Development and Consulting Not-for-Profit Corporation in 1990, by its Founder, Admiral, Rick R. Dobson, Jr., and had its birthplace at Cornell University in Ithaca, N.Y. The ISA is presently Seeking International Treaty -&-Charter Status by the Global Space Community, by gaining Governmental and Non-Governmental Membership and Signatories to the **ISA Charter**. The International Space Agency Organization is a strictly non-political and non-ideological organization.

From 1990 to Present, the **ISA** has conducted numerous formal International Diplomatic Meetings in Washington, D.C., and hundreds of private and informal meetings, with key persons from over 43 Nations, representing the Governmental, Commercial, Scientific, Academic, and Private Space Sectors and Communities, which participated in, and attended these meetings. These meetings have been very successful in building growing global support, and understanding, for the **ISA Charter**, and the **ISA** Vision, Mission, and Goals Globally. The **ISA** continues to the Present Day, to promote, develop, and conduct Global Diplomacy, Out Reach, and Public Relations and Efforts to this end’s.

~ RECENT ~

From October 10th to October 19th of 2002 the **ISA** had a presence at the World Space Congress in Houston, Texas. This is the largest of the international space sector events Globally, and is held just every 10 years. Every major Nation and Organization involved in the Space Sector, and Space Exploration, Technology, and Science had a presence at the 2002 World Space Congress. The **ISA** made many formal appeals for support at this event, and conducted two “2” international press conferences. The International Space Agency also participated in and attended the 1992 World Space Congress in Washington, D.C., and has since 1990 conducted or participated in hundreds of important meetings.

The desire to develop increased international cooperation in space exploration and science is at an all time high. The **ISA** has benefited dramatically from this present spirit of good will and hope by the international space community, and it is the **ISA**’s hope that this spirit of good will and hope can be fully utilized.

A number of major space nations and organizations are now very eager to make the **ISA** Vision & Mission a serious part of their future plans, and the center of any future international space activities. This support presently is at a point, that with serious interest and support by the International Space Community; Could lead to a very dramatic and historic beginning to a new and exciting chapter in Human Space Exploration by the Global Space Community.

~ FUTURE ~

Here is just one of many projects the **ISA** could undertake, “with International Support & Leadership”, to benefit its member Nations and organizations, by providing tangible cost savings, conserving limited resources, making better use of intellectual assets globally, and deploying space activities beyond the National domain and capabilities:

An International Space Plane Program, utilizing a state of the art Electromagnetic Assisted Launch System, which would provide routine and daily Single Stage to Orbit (SSTO) operations and capability, which would be Managed like Airbus in Europe. This Space Plane Technology would be a 100% reusable space launch system, which would have unlimited potential. ***Note:** In every U.S. Space Shuttle launch the 13 story high main tank, which were worth many millions of U.S.A. taxpayer dollars and represented large amounts of high-grade metal ores and man-hours, was totally wasted on every launch. As it was burned up on reentry after separation from the shuttle. All vertical launch vehicles presently in use by the U.S.A. and the world’s space powers waste about 70% of the vertical launch vehicle, similar to the same dramatic waste represented by the example of the main tank of the Shuttle Transportation System. A fully reusable International Space Plane Program would offer a sustainable and tangible solution and alternative to these substantial problems of waste of critical resources.

Just a few other space projects that would benefit from the support of the International Space Community, through the **ISA**; include: Mars Missions & Base; Return to Luna “Earth’s Moon” to Stay; Solar System Exploration; Astronomy; Space Sciences;

Astrobiology; Complex Space Ships & Craft; Orbital Space Stations; Space & Planetary Bases and Settlements; Central Space Sciences Databases and Archives; and any future Deep Space and Extra-Solar Exploration Programs.

Author: Admiral, Rick R. Dobson, Jr. “Founder of the International Space Agency”

Copyright © 1992 / Republished & Updated Copyright © 2005 / Republished © 2019 / All Rights Are Reserved

Why Support An International Space Agency (ISA)?

There are many reasons for supporting the concept of an International Space Agency (ISA), but first the idea should be clearly defined. When the average person thinks of an International Space Agency (ISA), the first thing that comes to mind is the United Federation of Planets and Starfleet from the science fiction series, Star Trek. by Gene Roddenberry. This certainly is a viable impression of what an International Space Agency (ISA) is, but of course, this is fiction. In such a structure, instead of having representatives from planets as in Star Trek, we have representatives from each member country on Earth that joins this international entity. Also one must remember the idea of an International Space Agency (ISA), unlike Star Trek, is scientific fact and is much more realistic. This is not a new concept and, and has been a legal corporation since 1990. and was founded in 1986. In this concept of an International Space Agency (ISA), each nation invests resources and voluntarily sends its people via a diplomatic or special visa, to serve and work in this international agency for a termed period of time. In this structure, international treaties, laws, and policies are set that each member government or organization must follow. If a member country sends any of its citizens to work in this area of international concern, than, during the period of service, that individual must abide by all international treaties, contracts, and laws, which supercede the laws of the individual's country, and follow established rules and regulations of the International Space Agency (ISA). In addition, a global international language must be set as a core standard, so that all members of the International Space Agency (ISA), and its Officers and Personnel can effectively and efficiently communicate. Since the most global Science and Technology “Internet & Academia” and Aerospace “Airline Pilots” used languages on Earth is English, its recommended the means of communication, internally with in the International Space Agency (ISA) and at the International Space Academy be set as English. This is a very serous issue, as due to the complexity and high level of the very dangerous nature of space exploration in the activities of the International Space Agency (ISA), a misunderstanding in critical operations could lead to a mishap or catastrophe that could lead to the loss of life or destruction of assets.

~ ISA AS KEY GLOBAL FOCAL POINT AND ENABLER ORGANIZATION ~

The formation of an ISA does not in any way ask for the abolition of individual space agencies like NASA, Roscosmos, CNSA, ESA, ISRO, or JAXA; or even compete directly with Aerospace & Commercial enterprises. It calls for these agencies and corporations to continue to perform the same functions for each member nation, but now in conjunction with the ISA. For those nations who do not have a national space program of their own, the ISA allows them better access to space technology and the ability to participate in the global space effort. For Corporations Globally, they will now be able to utilize, piggy back, and access a Global Space Program & Space Transportation System of unlimited potential and capability, into a New Space Frontier of unlimited resources, opportunities, and potential. This will create new global economies and employment in the many trillions of dollars, as well as opening new worlds and frontiers to human settlements and exploration. The ISA will act as a key focal point and enabler organization in this regards.

~ GLOBAL FOREIGN RELATIONS AND DIPLOMATIC BENEFITS ~

One may ask what is the purpose of all this? In the opinion of the writer of this document, there are many benefits. First and foremost is international diplomacy and cooperation. Whenever countries are brought together to work for a common goal, it enhances cooperation and increases the chance for world peace. We saw this type of cooperation between Russia and the United States with Soyuz & Apollo Link Up, MIR space station, and we are seeing this cooperation even more with the International Space Station (ISS). Since in this proposed ISA, there is no military use of space allowed “Earth Orbit Out / Beyond Earth Orbit” and countries are not competing for their own goals, there is more of a sharing between member nations, thus resulting in better foreign relations. This sharing brings about less concern for ideology and more focus on cooperation and resulting mutual benefits. This is not to say that nations cannot have a military, national space agency, or a national identity, but that is outside, and separate from, the mission and purpose of ISA.

~ GLOBAL ECONOMIC AND STANDARD OF LIVING BENEFITS ~

In addition to international diplomacy, an ISA can strengthen global economies. For example, there may be many developing countries that cannot afford the technology and standard of living of "G7" western industrialized countries and other developed countries globally enjoy. By being a member of ISA, even though these developing countries cannot afford the investments of western industrialized nations, they can certainly reap the benefits of membership. These nations will have access to science, technology, and education that would otherwise be impossible. With help of stronger industrialized nations, developing nations can learn new techniques in medicine, environmental technology, how to raise the standard of living of their citizens and how to assist their disabled citizens, through increased access to technology. As ISA matures and grows, the resulting Global Space Programs, Projects, and Missions will dramatically spawn a new non-military and peaceful civil: *Global Space Industrial Complex* and *Global Space Exploration Economy*.

~ GLOBAL MARKETS AND TRADE BENEFITS ~

An ISA can improve the world economy and make world markets more accessible and facilitate world trade in the areas of civil and peaceful science and technology. Unlike present global trade policies between countries, which compete for trade in an adversarial manner, in an ISA, competition is not based on adversarial objectives. It is just shared technology and markets, yielding mutual benefits and trade. This is not to say that competition is negative as it is the basis of capitalism, the most successful economic system to date. In the ISA, there is competition, but it is not adversarial, it is symbiotic and collaborative. For example, if Japan were a member and was selling microprocessors, and wanted to put a plant in Russia in support of a global civil space program, it would not take jobs away from

Japanese. This exchange of technology would just enhance job opportunities for all member nations and would especially help other nations globally who have consistent unemployment. This brings us to the next huge benefit of ISA, is global employment opportunities.

~ GLOBAL EMPLOYMENT AND RETASKING BENEFITS ~

In the early 1990s, many defense and aerospace workers globally lost their jobs due to military cutbacks as a result of the end of the Cold War. There were lost opportunities for these employees resulting in a reverse trickle-down effect. As a result, massive lay-offs took place; people purchased less goods and services, reducing the gross national and gross domestic products of most nations. Revenues declined due to lack of employment and deficits resulted. It took the global economy some five years to recover and it is still an economy for the wealthy and CEO's or major corporations. Even with the so-called seven-year expansion, Alan Greenspan has warned us of the possibility of another recession like in 1991. When a major industrialized nation goes into a recession, this has a negative impact on the world due to the lack of trading opportunities and the effects of the nation's currency and international financial markets. We saw this with the advent of the Euro in 1999. The Euro did not perform as well as originally planned, thus having a negative impact on the nations of the European Union. With an ISA in effect, these workers that are affected by downturns in the economies of member nations can be retrained for jobs within the ISA network, and for use in Global Space Programs, Projects, and Missions. For example the exploration and settlement efforts on Earth's Moon and on Mars. They can use academic, scientific, technical, military, or other experience and apply it to their new responsibility with the ISA to save on training costs, assisting in diversification into different professional fields, and opening up more job opportunities. Also with the Internet and the World Wide Web, an ISA is even more efficient and can now employ from each member nation a group of computer information technology specialists from each member nation, which can design their nation's webpage to be linked to the main webpage of ISA. The goal of this network would be to transmit and exchange information that is rapidly translated into the many languages of the member nations and organizations of ISA, so that for example: *Comet and Asteroid Hunters & Researchers Globally can freely and rapidly exchange critical information and research regarding potentially dangerous Earth Impactors*. Also ISA would build a central supercomputer facility that would act as a central database & archive for space & planetary sciences, astronomy, and space technology. With enhancement of fiber optics and wide area networks, this goal is becoming more easily attainable. The employment of ISA web and computer center personnel will help each member nation's employment situation and per capita income as well as revenues from employment taxes needed to cut national deficits.

~ GLOBAL COLLABORATION AND COOPERATION BENEFITS ~

Group funded launch facilities and space exploration programs would be very important benefit of an ISA, since this is one of its main goals of existence. It is more efficient and less expensive for each country to fund a space station program or planetary research and settlement program, for example, as part of a collective and collaborative group of countries. We see this efficient use of funds with European member nations with in the European Space Agency, which is a Regional European Space Agency, and is the smaller cousin of the larger Global International Space Agency. This of course results in more international cooperation and better relations because nations are sharing a common project or program in a Global Space Program. Even group space plane launches, satellite launches, etc. bring about different ideals from the different countries involved. For example, if one country has better technology and another has better know-how or intellectual resources, the group project can take the best talents from each country. Therefore, the result will be a much higher quality and robust group space project or program. In addition, the expenses and responsibilities are shared among nations, therefore preventing huge deficits of individual national resources, while giving each nation full access to global space programs, projects, and missions at a fraction of the total cost. This strategy will allow the ISA to provide not for profit services to its member nations and organizations at substantially less cost per member nation or organization, while also providing an International Space Program & Space Transportation Infrastructure of scope, scale, and duration that is sustainable and robust, that would be out side the national domain, ability, and capability. In a way, one can think of the ISA as a national rail or highway system that is not built for profit, but is built to provide infrastructure in which governments, corporations, and individuals will utilize freely in commerce, cargo, and transportation by a wide array of unlimited potentials. ISA will simply act as the focal point, overseer, maintaining, and enabling organization of this global space program and transportation system and infrastructure, and will do so through the collective contributions and dedicated resources and support of its member nations and organizations. This will create a massive emerging global space economy in the many trillions of dollars. New Frontiers historically have always created opportunity.

~ SCIENCE AND TECHNOLOGY SPIN OFF BENEFITS ~

Spin-off technology is a huge benefit of an ISA. Unlike with individual space agencies, where the spin-off is only accessible to the people of that nation, this would make it accessible to all nations. Spin-offs can be in the area of computer technology, environmental research, the apparel industry, health and safety, medical spin-offs, and technology to help people with disabilities lead more independent and productive lives. Many of the spin-offs that have come out of these previously mentioned areas, have come out of NASA alone. If you had several member nations and their respective space agencies working together, the amount of spin-offs would metastasis logarithmically. This would allow many nations to generate technical transfers that would benefit all member nations. For example, in 1986, the American President and the executive branch had fully funded a program for NASA called the Earth Observatory System which is a high-resolution spectrometer observing the ozone layer and deforestation. With ISA, this program would have been funded, not just by one nation, but by many nations. This would result in a much larger project for which not only the western hemisphere's environments would benefit, but each member nation's ecology would benefit. As a result, there would be many more environmental spin-offs and funding would increase because the sources of spin-offs and funding would increase substantially. The benefits to global orbital remote sensing in the fields of climatolgy, weather, geology, natural resource management, agriculture, map making, and civil engineering, ect., would be massive, and as a result scientific & technological advances in these fields would be rapid.

~ INTERNATIONAL SPACE ACADEMY AND EDUCATIONAL BENEFITS ~

An ISA would greatly help in the area of education and training. In such a structure, there is no longer the isolated educational systems of particular countries which may not have the highest academic standards. They also may not have the best access to math, science and technology. However, with an ISA, education and educational systems would be shared by all member nations. For example, if a country like Peru which is a developing country, does not have the funding or educational quality that Japan or France have, then Japan and France can share some of their educational acumen with this country, through ISA programs and infrastructure. These more advanced countries can help them come up with better ways of educating their citizens, such as academic programs from major universities beamed by satellite into remote and poor areas, like is done in India by ISRO. This results in stronger cooperation between nations, improved employment opportunities and improved world economies. Indeed, one of the key programs and divisions of the ISA would be the International Space Academy, which would be an academic and training academy like the U.S. Naval Academy, with elements of NASA Astronaut Training Program and Universities mixed in. Like the U.S. Naval Academy, the International Space Academy would bring a wide array of officer, scientific, and personnel recruits from all the member nations and organizations, who would then go through standardized training in order to create a uniform and cohesive core culture and high personnel standards and character in physical, academic, technical, and leadership skills. The ISA, Space Academy would provide standardized international training programs and high quality space personnel for ISA International Space Programs, Projects, and Missions, as well to member nations and organizations globally of ISA. The International Space Academy will bring together the best Human Talent, Expertise, and Minds of Earth, for Peaceful, Beneficial, and Nobel Deeds & Enterprises on Behalf of ALL Mankind!

~ GLOBAL TOTAL QUALITY MANAGEMENT AND STANDARDS BENEFITS ~

Total Quality Management would definitely result in establishing an ISA. TQM says quality is at all levels and anyone who receives output is your customer. It also states that all those involved in the organization are empowered in decision making that impacts the entity. In an ISA, all member nations would work together for common goals and objectives in Global Space Programs, Projects, and Missions, and international diplomacy and collaboration. Therefore, much of the decisions would be shared by the member nations, resulting in empowerment for each member. It is synergy where the whole is greater than the sum of its parts. For the organization to run efficiently, quality and standards would have to be the responsibility of each member nation. Just like in a corporation, quality circles of nations can be set up to facilitate the involvement of group decision making with the input of all member nations, even those of developing status. This can be seen clearly in multi-national corporations like Airbus Industries, where components of a completed aircraft come from many countries, and so it is critical for management, quality control, and standardization across the Airbus facilities to be effectively employed. If a tail section from one country, a fuselage from another country, and wings and engines from yet other countries, all come together in a central assembly facility in a host country, it would be a complete disaster if TQM and Standards were not aggressively employed. Any member nation that does not, or can not, abide by the rules, regulations and quality standards of the ISA, may be forced to relinquish their membership if the deviant behavior is not rectified or solvable. This results in a cooperative and efficient organization, vertically, and horizontally, through its International Space Administration, International Space Centers, and International Space Commands, and TQM will be Engrained with in the Core Culture of its Leadership, Officers, and Personnel.

~ GLOBAL COMMON ACCOUNTING BENEFITS ~

The accounting system of ISA is something of paramount importance. Much like accounting systems of governments, there must be systems of receivables, payables, revenues, and expenses for such a large structure and a diverse array of complex and large Global Space Programs, Projects, and Missions. A "General Accounting Office" skilled in large structure non-profit accounting would be necessary in order for such a structure to be managed efficiently and effectively. A benefit here in setting up an ISA, is that all members would be under the same accounting and tax system. ISA would not be concerned or impacted with the tax and accounting systems of individual countries, since each country has its own system. The fact that ISA would have a uniform accounting system which all members must abide by, would assist in cooperation and unified financial goals and objectives, and create core oversight, leading to ethical and effective use of financial resources which have been dedicated to ISA Programs, Projects, and Missions.

~ GLOBAL HUMANITARIAN SPIN OFF BENEFITS ~

The ISA spin off technologies will provide many benefits to people with disabilities in each of the member countries. Since there are several member nations sharing technology for the good of humanity of Earth as a whole, much of the technology that comes from space spin-off technology or technical transfers, with different or new applications from space research, can be applied to aid those with disabilities. An example is in NASA's planetary probes program, there are many studies in robotics. The result of this technology came partly in the form of robots assisting a person with many severe disabilities in enhancing or performing independent living skills. With an ISA, not only do you have the expertise of the Americans, there is the technology of many other member nations. As a group cooperative, there can be improvements in adaptive software and other adaptive equipment and technologies, in the area of communications, daily living skills, mobility, processing skills, vocational and educational assistance. This will result in improved employment opportunities and adaptive aiding technologies for people with disabilities in all member nations of the ISA, resulting in stronger international economies & improved international relations. Thus enabling many benefits of human compassion & empathy.

~ CONCLUSION ~

There are definitely many benefits to having an International Space Agency (ISA), even more numerous to mention than what has been previously discussed here. Benefits already discussed include employment opportunities, economic improvements, international diplomacy, spin-off technology, total quality management TQM, group financial and accounting systems. Other benefits include more efficient space programs, projects, and missions for member nations and for Earth at large, space programs that are less expensive per nation, improving international relations, world economies, and the lives of people with disabilities through technology. Most importantly, the International Space Agency (ISA) will provide International Space Programs, Projects, Missions, and Space Transportation Infrastructure of Scope, Scale, and Duration that is Sustainable and Robust, and is clearly OUTSIDE the Ability or

Capability of the National Domain. Indeed, with all these benefits, it's therefore evident that anyone will see this pursuit of historic proportions, as a noble and worthwhile endeavor, which will have great benefits to all Nations & Peoples of Earth. Presently, Global tensions are increasing and becoming more polarized, it's therefore logical that ISA offers hope to ease or reduce these tensions.

Ad-Astra! To The Stars! In Peace For All Mankind!

Manned Mars Mission In 10 Years "2027" -&- Human Settlements In 30 Years "2050"

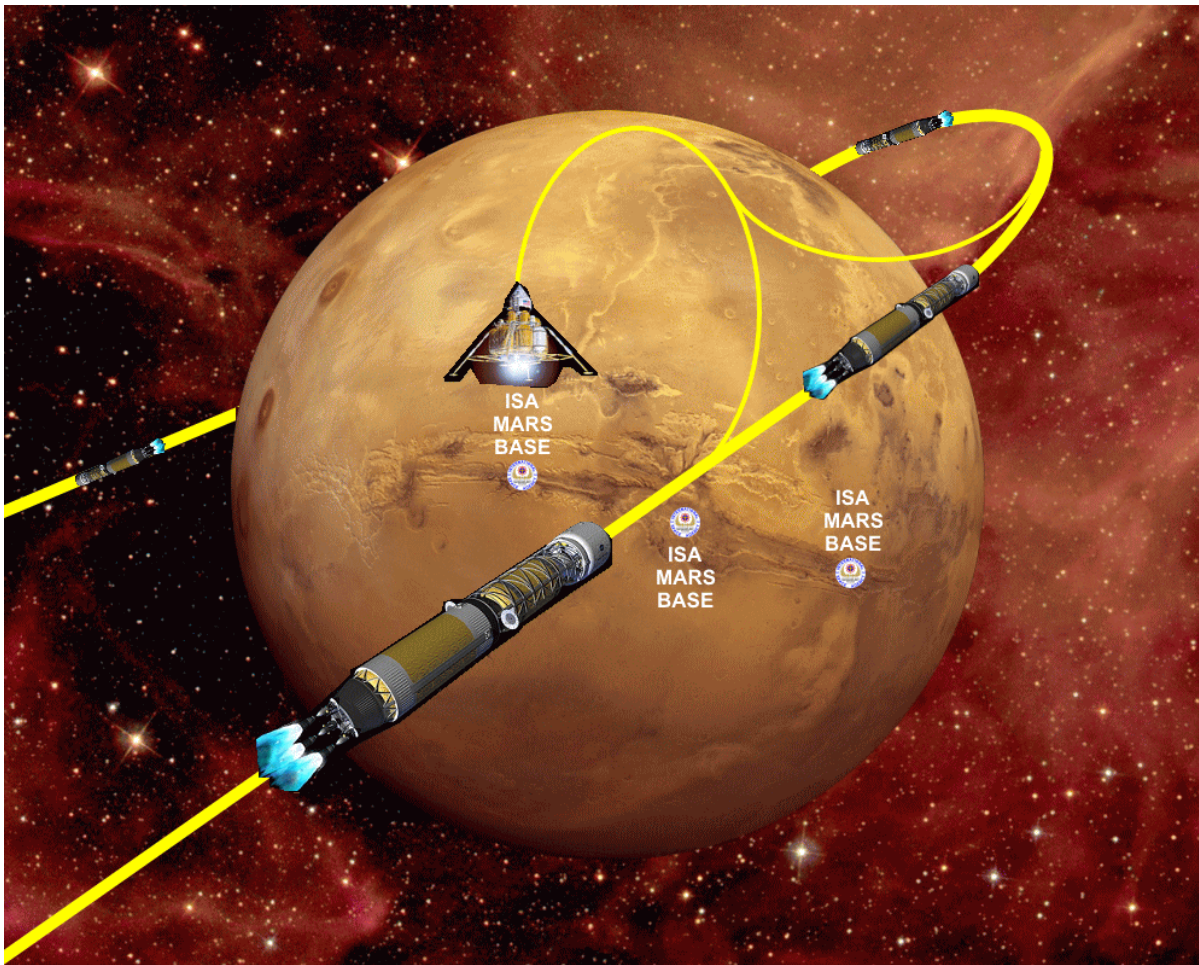

International Space Agency (ISA) - Proposed Mars Mission Profile & First Humans On Mars by 2027-2029

With the Focus & Main Goal of Setting Up Established Self Sufficient Human Settlements on Mars by 2050

- 2020 - 6 Months** - Diplomatic and Treaty and Basic Planning Phase and Mars Mission and Crew Profile Development
- 2020 - 6 Months** - Mars Mission Core Program Personnel and Crew Appointments, Selections, Recruitment, and Training
- 2021 - 6 Months** - Mars Mission Basic Infrastructure Planning and Spacecraft, Vehicles, Equipment Design
- 2021 - 6 Months** - Mars Mission Final Infrastructure Planning and Space Craft, Vehicles, Equipment Design
- 2022 - 1 Year** - Mars Mission Prototypes Development and Testing - Phase 1 - Preliminary Development
- 2023 - 1 Year** - Mars Mission Prototypes Development and Testing - Phase 2 - Terminal Limits & Quality Control Standards
- 2024 - 1 Year** - Mars Mission Prototypes Development and Testing - Phase 3 - Pre-Operational & Limited Operational Testing
- 2025 - 1 Year** - Mars Mission Final Production, Construction, Full Operational Testing, and Pre-Mission Preparation
- 2026 - 1 Year** - Mars Mission Cargo Ships 1 & 2 leaves for Mars, 30 Days later Cargo Ships 3 & 4 Leave for Mars. When Cargo Ship 1 & 2 Safely Enter Mars Orbit, Primary Crew Ships 1 & 2 "Earth 1 & Earth 2" Leave for Mars. When Cargo Ship 3 & 4 Safely Enter Mars Orbit, Backup Crew Ships 3 & 4 "Earth 3 & Earth 4" Leave for Mars.
- 2027 - 1 Year** - With all 8 ships in Mars Orbit, All Supply Landers, Hab Landers, Ground Trans Port Vehicle Lander and Backup Lander/Return are sent to Primary Mars Landing Sites. After all Landers are safely on Mars, the Primary Crew Lander/Return vehicles depart for Mars surface. If all Landing Operations are successful a 8 to 12 month Mars Surface

Exploration Program will begin. * Once Mars Exploration successfully begins, Production of 8 more Spacecraft will be approved and production and assembly will begin.

2028 – 1 Year – If all goes well, when the first mission and all 8 space craft from Mars return to Earth the new spacecraft and crews should be ready for departure to Mars. Mission One Information and Data is rapidly evaluated and from learning and experience gained, and updates, revisions, and corrections are made to mission two.

2029-2034 – 5 Years - Once this stage occurs, the returned 8 space craft will be repaired, overhauled, refitted, re-supplied. This cycle will rotate on 1 year cycles at first, but as more space craft and crew are available the Cycles will decrease to 11 month Cycles, 10 month Cycles, and 9 month Cycles, ect. The goal would be that enough ships are established to provide monthly trips to/from Mars.

2035-2043 – 8 Years - Mars Operations for first 5 missions will be self contained and all crew will return to Earth with their ship. Once sufficient supplies and infrastructure is established, a semi-permanent Mars Outpost and Operations will be established, and crew assignments on Mars will be rotated in 2 separate 4 year cycles. This experience will prepare the way for a permanent settlement.

2044-2048 – 4 Years - Permanent Central Mars Base & Infrastructure & Personnel is Established. Mars Planetary Exploration & Human Settlement is started in earnest. The ISA secretly selects a group of ISA personnel who will be permanently stationed on Mars.

2049-2050 – 1 Years - Non-ISA Settlers secretly selected are sent to Mars and will stay permanently. Routine ISA Missions continue.

ISA International Mars Exploration Program Goal is to Establish Fully Self Sufficient Mars Settlement by 2050

NOTE: It must be noted here, that it is critical for the International Space Plane (ISP) Program and International Electromagnetic Assisted Launch System to be approved in 2019/2020 for this Mars Exploration Program to be conducted on the provided time table. This is due to the fact, that the massive amounts of personnel, resources, and hardware that will have to be launched into Earths Orbit, will require a fully reusable space launch system of scope, scale, longevity, and robustness, capable of providing 5 to 7 launches daily into Earths Orbit. Once the ISP Program is approved, it will take 5 to 7 years for it to come on line, and be fully operational. During this time, the planning, design, and development of the Mars Mission Hardware will take place, and recruitment and preparation of the crew members who will be sent to Mars. As the ISP Program comes on line the personnel and hardware for the Mars Mission should be ready for full assembly in Earth Orbit, and preparations made for mission deployment to Mars. During this time, Mars Hardware and Systems will be tested in Earth Orbit and on Luna.

Cargo Ship 1A) Un-manned & Automated Cargo Ship: Primary Mission Craft “Emergency Manned Capable”

* 8 Lander Pods: 1 Mars Base Supplies, 2 Support Equipment, 3 Power, 4 Sewer/Water, 5 Land Rover, 6 Science, 7 Construction, 8 LivingHab

* Cargo Ship in Mars Orbit Has Orbital Communications & Support Capability and has 1 Reserve Lander/Return Vehicle for emergency use

* Cargo Ships Are Designed For Low Fuel Use, Slow Long Duration Flights *Each Cargo Ship Carries A Space Tug & Transfer Vehicle

Cargo Ship 2A) Un-manned & Automated Cargo Ship: Backup Mission Craft “Emergency Manned Capable”

* 8 Lander Pods: 1 Mars Base Supplies, 2 Support Equipment, 3 Power, 4 Sewer/Water, 5 Land Rover, 6 Science, 7 Construction, 8 LivingHab

* Cargo Ship in Mars Orbit Has Orbital Communications & Support Capability and has 1 Reserve Lander/Return Vehicle for emergency use

* Cargo Ships Are Designed For Low Fuel Use, Slow Long Duration Flights *Each Cargo Ship Carries A Space Tug & Transfer Vehicle

Crew Ship 1A) Manned Space Craft: Primary Ship - "Earth-1" (A Crew)

* 4 Crew Modules with Artificial Gravity & 9 Core Micro-Gravity Modules & 1 Mars Lander (Primary Lander/Return Vehicle)

* Normal Crew: 8 (Emergency Max Crew: 16) **Note:** 2 Crew must have MD's and will act as Ships Medical Staff

* Command Crew 4: Ship Captain & Chief Pilot, Pilot/Navigator, Pilot/Flight & Propulsion Engineer, and Pilot/Computer Systems

* Scientific Crew 4: Biology Specialist, Radiation Specialist, Chemist, General Planetary Sciences with emphasis on Geology

* Crew Ships Are Designed For High Fuel Use, Fast Short Duration Flights *Each Crew Ship Carries A Space Tug & Transfer Vehicle

Crew Ship 2A) Manned Space Craft: Backup Ship - "Earth-2" (B Crew)

* 4 Crew Modules with Artificial Gravity & 8 Core Micro-Gravity Modules & 1 Mars Lander (Primary Lander/Return Vehicle)

* Normal Crew: 8 (Emergency Max Crew: 16) **Note:** 2 Crew must have MD's and will act as Ships Medical Staff

* Command Crew 4: Ship Captain & Chief Pilot, Pilot/Navigator, Pilot/Flight Engineer, and Pilot/Computer Systems

* Engineering Crew 4: Mining/Drilling Engineer, Construction/Civil Engineer, Materials/Structures Engineer, Machinist/Mechanical Engineer

* Crew Ships Are Designed For High Fuel Use, Fast Short Duration Flights *Each Crew Ship Carries A Space Tug & Transfer Vehicle

Cargo Ship 1B) Un-manned & Automated Cargo Ship: Primary Mission Craft "Emergency Manned Capable"

* 8 Lander Pods: 1 Mars Base Supplies, 2 Support Equipment, 3 Power, 4 Sewer/Water, 5 Land Rover, 6 Science, 7 Construction, 8 Living Hab

* Cargo Ship in Mars Orbit Has Orbital Communications & Support Capability and has 1 Reserve Lander/Return Vehicle for emergency use

* Cargo Ships Are Designed For Low Fuel Use, Slow Long Duration Flights *Each Cargo Ship Carries A Space Tug & Transfer Vehicle

Cargo Ship 2B) Un-manned & Automated Cargo Ship: Backup Mission Craft "Emergency Manned Capable"

* 8 Lander Pods: 1 Mars Base Supplies, 2 Support Equipment, 3 Power, 4 Sewer/Water, 5 Land Rover, 6 Science, 7 Construction, 8 Living Hab

* Cargo Ship in Mars Orbit Has Orbital Communications & Support Capability and has 1 Reserve Lander/Return Vehicle for emergency use

* Cargo Ships Are Designed For Low Fuel Use, Slow Long Duration Flights *Each Cargo Ship Carries A Space Tug & Transfer Vehicle

Crew Ship 1B) Manned Space Craft: Primary Ship - "Earth-3" (C Crew)

* 4 Crew Modules with Artificial Gravity & 9 Core Micro-Gravity Modules & 1 Mars Lander (Primary Lander/Return Vehicle)

* Normal Crew: 8 (Emergency Max Crew: 16) **Note:** 2 Crew must have MD's and will act as Ships Medical Staff

* Command Crew 4: Ship Captain & Chief Pilot, Pilot/Navigator, Pilot/Flight & Propulsion Engineer, and Pilot/Computer Systems

* Scientific Crew 4: Biology Specialist, Radiation Specialist, Chemist, General Planetary Sciences with emphasis on Geology

* Crew Ships Are Designed For High Fuel Use, Fast Short Duration Flights *Each Crew Ship Carries A Space Tug & Transfer Vehicle

Crew Ship 2B) Manned Space Craft: Backup Ship - "Earth-4" (D Crew)

* 4 Crew Modules with Artificial Gravity & 8 Core Micro-Gravity Modules & 1 Mars Lander (Primary Lander/Return Vehicle)

* Normal Crew: 8 (Emergency Max Crew: 16) **Note:** 2 Crew must have MD's and will act as Ships Medical Staff

* Command Crew 4: Ship Captain & Chief Pilot, Pilot/Navigator, Pilot/Flight Engineer, and Pilot/Computer Systems

* Engineering Crew 4: Mining/Drilling Engineer, Construction/Civil Engineer, Materials/Structures Engineer, Machinist/Mechanical Engineer

* Crew Ships Are Designed For High Fuel Use, Fast Short Duration Flights *Each Crew Ship Carries A Space Tug & Transfer Vehicle

Mars Program & Mission Funding: (32 Mission Crew = Crew A – 8, Crew B – 8, Crew C – 8, Crew D 8

1) 77% Government Funding (12 Crew): USA (14%)(2 Crew), Russia (14%)(2Crew), China (14%)(2 Crew), Europe/ESA (14%)(2 Crew), Japan (7%)(1 Crew), India (7%)(1 Crew), Other Countries (7%)(2 Crew) through their National Space Agencies dedicate Manpower, Expertise, Resources, Funding to provide the Central Infrastructure & Space Craft Elements. This would cover 77 percent of the total Infrastructure and Program Costs.

2) 7% Corporate & Commercial Funding (1 Crew)

3) 7% Scientific & Academic Funding (1 Crew)

4) 7% Private Support & NGO Funding (1 Crew)

5) 2% Media & News Pool (1 Crew)

6) ISA Dedicated Command & Operations Crew (16 Crew)

**Routine Access To Earth Orbit By 2026-2028 / First Humans On Mars By 2028-2031 / First Human Self Sufficient Settlement On Mars By 2050
International Space Agency (ISA) - International Mars Exploration (IME) Program - & - International Solar Cruiser (ISC) Program - & - International Space Plane (ISP)
Program - First ISA Mission To Mars - IME/ISC/ISP Programs - Est. Total Cost:**

A – IME/ISC/ISP Program - Administrators & Program Management – \$1,810,000	\$7,770,777,077
01) ISC Program – Program Director – 1 PHD Chief Engineer – \$100,000	\$0,000,100,000
02) ISC Program – Director of Administration & Personnel – 1 PHD/MSci/BS/BA – \$90,000	\$0,000,090,000
03) ISC Program – Director of Personnel & Talent Recruitment – 1 PHD/MSci/BS/BA – \$90,000	\$0,000,090,000
04) ISC Program – Director of Personnel Benefits & Payroll – 1 PHD/MSci/BS/BA – \$90,000	\$0,000,090,000
05) ISC Program – Director of Personnel Training & Qualifications – 1 PHD/MSci/BS/BA – \$90,000	\$0,000,090,000
06) ISC Program – Director of Personnel Travel & Housing – 1 PHD/MSci/BS/BA – \$90,000	\$0,000,090,000
07) ISC Program – Director of Dispersing & Accounting – 1 PHD/MSci/BS/BA – \$90,000	\$0,000,090,000
08) ISC Program – Director of Records & Databases – 1 PHD/MSci/BS/BA – \$90,000	\$0,000,090,000
09) ISC Program – Director of Public & Media Relations – 1 PHD/MSci/BS/BA – \$90,000	\$0,000,090,000
10) ISC Program – Director of Media Services & Historical Archives – 1 PHD/MSci/BS/BA – \$90,000	\$0,000,090,000
11) ISC Program – Director of Meetings & Conferences – 1 PHD/MSci/BS/BA – \$90,000	\$0,000,090,000
12) ISC Program – Director of Manuals & Publications – 1 PHD/MSci/BS/BA – \$90,000	\$0,000,090,000
13) ISC Program – Director of Facilities & Physical Assets – 1 PHD/MSci/BS/BA – \$90,000	\$0,000,090,000
14) ISC Program – Director of Ground Transportation & Motorpool Assets – 1 PHD/MSci/BS/BA – \$90,000	\$0,000,090,000

15)	ISC Program – Director of Aircraft & Aviation Assets – 1 PHD/MSci/BS/BA – \$90,000	\$0,000,090,000
16)	ISC Program – Director of Information Technology & Webmaster – 1 PHD/MSci/BS/BA – \$90,000	\$0,000,090,000
17)	ISC Program – Director of Computer & Electronic Security – 1 PHD/MSci/BS/BA – \$90,000	\$0,000,090,000
18)	ISC Program – Director of Personnel Security – 1 PHD/MSci/BS/BA – \$90,000	\$0,000,090,000
19)	ISC Program – Director of Facilities Security – 1 PHD/MSci/BS/BA – \$90,000	\$0,000,090,000
20)	ISC Program – Director of Information Security – 1 PHD/MSci/BS/BA – \$90,000	\$0,000,090,000

B - IME/ISC/ISP Program - Engineering & Technology & Research & Development Management – \$5,400,000

01)	ISC Program – Director of Ship 0-Gravity Protocols & Design – 1 PHD Engineer – \$90,000	\$0,000,090,000
02)	ISC Program – Director of Ship Artificial-Gravity Protocols & Design– 1 PHD Engineer – \$90,000	\$0,000,090,000
03)	ISC Program – Director of Ship Superstructure & Structures – 1 PHD Engineer – \$90,000	\$0,000,090,000
04)	ISC Program – Director of Ship Mechanical & Control Systems – 1 PHD Engineer – \$90,000	\$0,000,090,000
05)	ISC Program – Director of Ship Electrical & Power Systems – 1 PHD Engineer – \$90,000	\$0,000,090,000
06)	ISC Program – Director of Ship Power Storage & Battery Systems – 1 PHD Engineer – \$90,000	\$0,000,090,000
07)	ISC Program – Director of Ship Electronic & Computer Systems – 1 PHD Engineer – \$90,000	\$0,000,090,000
08)	ISC Program – Director of Ship Communications & Navigations Systems – 1 PHD Engineer – \$90,000	\$0,000,090,000
09)	ISC Program – Director of Ship Radar & Sensing Systems – 1 PHD Engineer – \$90,000	\$0,000,090,000
10)	ISC Program – Director of Ship Life Support & Atmosphere Systems – 1 PHD Engineer – \$90,000	\$0,000,090,000
11)	ISC Program – Director of Ship Environmental Systems – 1 PHD Engineer – \$90,000	\$0,000,090,000
12)	ISC Program – Director of Ship Propulsion & Thruster Systems – 1 PHD Engineer – \$90,000	\$0,000,090,000
13)	ISC Program – Director of Ship Nuclear Systems & Radiation Shielding – 1 PHD Engineer – \$90,000	\$0,000,090,000
14)	ISC Program – Director of Ship Fuel Storage & Cryogenic Systems – 1 PHD Engineer – \$90,000	\$0,000,090,000
15)	ISC Program – Director of Ship Atmosphere Integrity Emergency Repair – 1 PHD Engineer – \$90,000	\$0,000,090,000
16)	ISC Program – Director of Ship Fire Suppression & Monitoring Systems – 1 PHD Engineer – \$90,000	\$0,000,090,000
17)	ISC Program – Director of Ship Emergency Crew Escape Systems – 1 PHD Engineer – \$90,000	\$0,000,090,000
18)	ISC Program – Director of Ship Airlock & Hatch & Docking Port Systems – 1 PHD Engineer – \$90,000	\$0,000,090,000
19)	ISC Program – Director of Ship Maintenance & Repair Tools Design – 1 PHD Engineer – \$90,000	\$0,000,090,000
20)	ISC Program – Director of Ship Micro Meteorite Shielding & Design – 1 PHD Engineer – \$90,000	\$0,000,090,000
21)	ISC Program – Director of Ship Cosmic Radiation Shielding & Monitoring – 1 PHD Engineer – \$90,000	\$0,000,090,000
22)	ISC Program – Director of Ship Water Storage & Purification Systems – 1 PHD Engineer – \$90,000	\$0,000,090,000
23)	ISC Program – Director of Ship Waste Storage & Reclamation Systems – 1 PHD Engineer – \$90,000	\$0,000,090,000
24)	ISC Program – Director of Ship Hygiene & Biological Waste Systems – 1 PHD Engineer – \$90,000	\$0,000,090,000
25)	ISC Program – Director of Ship Personal Hygiene Bay Design – 1 PHD Engineer – \$90,000	\$0,000,090,000
26)	ISC Program – Director of Ship Crew Galley Design – 1 PHD Engineer – \$90,000	\$0,000,090,000
27)	ISC Program – Director of Ship Food Storage & Preparation Systems – 1 PHD Engineer – \$90,000	\$0,000,090,000
28)	ISC Program – Director of Ship Medical Bay Design & Systems – 1 MD/PHD Engineer – \$90,000	\$0,000,090,000
29)	ISC Program – Director of Ship Physical Fitness Bay Design & Systems – 1 PHD Engineer – \$90,000	\$0,000,090,000
30)	ISC Program – Director of Ship Berthing Bay & Personal Space Design – 1 PHD Engineer – \$90,000	\$0,000,090,000
31)	ISC Program – Director of Ship Crew Ergonomics & Interior Design – 1 PHD Engineer – \$90,000	\$0,000,090,000
32)	ISC Program – Director of Ship Crew Comfort & Furniture Design – 1 PHD Engineer – \$90,000	\$0,000,090,000
33)	ISC Program – Director of Ship Crew Entertainment Bay Design – 1 PHD Engineer – \$90,000	\$0,000,090,000
34)	ISC Program – Director of Ship Crew Uniforms & Linen Design – 1 PHD Engineer – \$90,000	\$0,000,090,000
35)	ISC Program – Director of Ship Crew Space Suit & Safety Gear Design– 1 PHD Engineer – \$90,000	\$0,000,090,000
36)	ISC Program – Director of Ship Machinist – Quality Control – 1 PHD Engineer – \$90,000	\$0,000,090,000
37)	ISC Program – Director of Ship Machinist – Safety & Standards – 1 PHD Engineer – \$90,000	\$0,000,090,000
38)	ISC Program – Director of Ship Machinist – Specifications Verification – 1 PHD Engineer – \$90,000	\$0,000,090,000
39)	ISC Program – Director of Ship Machinist – Blueprints & Microfiche – 1 PHD Engineer – \$90,000	\$0,000,090,000
40)	ISC Program – Director of Ship Machinist – CNC Programmer – 1 PHD Engineer – \$90,000	\$0,000,090,000
41)	ISC Program – Director of Ship Machinist – CNC Operations – 1 PHD Engineer – \$90,000	\$0,000,090,000
42)	ISC Program – Director of Ship Machinist – Tool & Die Fabricator – 1 PHD Engineer – \$90,000	\$0,000,090,000
43)	ISC Program – Director of Ship Machinist – Composite Materials – 1 PHD Engineer – \$90,000	\$0,000,090,000
44)	ISC Program – Director of Ship Machinist – Ferrous Materials – 1 PHD Engineer – \$90,000	\$0,000,090,000
45)	ISC Program – Director of Ship Machinist – Non-Ferrous Materials – 1 PHD Engineer – \$90,000	\$0,000,090,000
46)	ISC Program – Director of Ship Machinist – Heat Resistant Materials – 1 PHD Engineer – \$90,000	\$0,000,090,000
47)	ISC Program – Director of Ship Machinist – Natural-Magnetic Materials – 1 PHD Engineer – \$90,000	\$0,000,090,000
48)	ISC Program – Director of Ship Machinist – Electro-Magnetic Materials – 1 PHD Engineer – \$90,000	\$0,000,090,000
49)	ISC Program – Director of Ship Machinist – Electroconducting Materials – 1 PHD Engineer – \$90,000	\$0,000,090,000
50)	ISC Program – Director of Ship Machinist – Exotic & Rare Materials – 1 PHD Engineer – \$90,000	\$0,000,090,000
51)	ISC Program – Director of Ship Machinist – Fasteners & Rivets – 1 PHD Engineer – \$90,000	\$0,000,090,000
52)	ISC Program – Director of Ship Machinist – Welding & Fusing – 1 PHD Engineer – \$90,000	\$0,000,090,000
53)	ISC Program – Director of Ship Machinist – Glues & Adhesives – 1 PHD Engineer – \$90,000	\$0,000,090,000
54)	ISC Program – Director of Ship Machinist – Foundry & Molding – 1 PHD Engineer – \$90,000	\$0,000,090,000
55)	ISC Program – Director of Ship Machinist – Grinding & Polishing – 1 PHD Engineer – \$90,000	\$0,000,090,000
56)	ISC Program – Director of Ship Machinist – Laser & Water Cutting – 1 PHD Engineer – \$90,000	\$0,000,090,000
57)	ISC Program – Director of Ship Machinist – Electroplating & Ion Coatings – 1 PHD Engineer – \$90,000	\$0,000,090,000
58)	ISC Program – Director of Ship Machinist – Corrosion Control – 1 PHD Engineer – \$90,000	\$0,000,090,000
59)	ISC Program – Director of Ship Machinist – Protective Coatings – 1 PHD Engineer – \$90,000	\$0,000,090,000
60)	ISC Program – Director of Ship Machinist – Lubricants – 1 PHD Engineer – \$90,000	\$0,000,090,000

C - IME/ISC/ISP Program – Manufacturing & Assembly & Construction Personnel – \$117,500,000

01)	ISC Program – Component & Parts Design - Design & CAD & Drafting - Personnel - 50 x \$50,000	\$0,002,500,000
02)	ISC Program – Foundry Pour/Mold/Casting of Raw Components/Parts/Metal Stock - Personnel - 50 x \$50,000	\$0,002,500,000
03)	ISC Program – Metal Rolling & Stamping of Raw Components/Parts/Metal Stock - Personnel - 50 x \$50,000	\$0,015,000,000
04)	ISC Program – Machining Of Raw Component & Parts - Machinist / Factory Technician - 300 x \$50,000	\$0,015,000,000
05)	ISC Program – Component & Parts Manufacturing - Machinist / Factory Technician - 300 x \$50,000	\$0,015,000,000
06)	ISC Program – Component & Parts Inspection & Preparation - Machinist / Factory Technician - 200 x \$50,000	\$0,010,000,000
07)	ISC Program – Component & Parts Assembly - Machinist / Factory Technician - 100 x \$50,000	\$0,005,000,000
08)	ISC Program – Systems Manufacturing & Assembly - Machinist / Factory Technician - 100 x \$50,000	\$0,005,000,000
09)	ISC Program – Major Structures Manufacturing & Assembly - Machinist / Factory Technicians - 50 x \$50,000	\$0,002,500,000
10)	ISC Program – Final Module And Bay Manufacturing & Assembly - Factory Technicians - 50 x \$50,000	\$0,002,500,000
11)	ISC Program – Electricians & Electrical - Specialists & Technicians - 50 x \$50,000	\$0,002,500,000
12)	ISC Program – Avionics & Electronics & Computer Hardware - Specialists & Technicians - 50 x \$50,000	\$0,002,500,000
13)	ISC Program – Ducting & Vents - Specialists & Technicians - 50 x \$50,000	\$0,002,500,000
14)	ISC Program – Plumbing & Piping - Specialists & Technicians - 50 x \$50,000	\$0,002,500,000
15)	ISC Program – Surface Coating - Specialists & Technicians - 50 x \$50,000	\$0,002,500,000
16)	ISC Program – Module & Bay Interior - Finishers & Technicians - 50 x \$50,000	\$0,002,500,000
17)	ISC Program – Space Suit Design, Manufacture, Assembly - Specialists & Technicians - 50 x \$50,000	\$0,002,500,000
18)	ISC Program – Propulsion & Thruster Systems - Specialists & Technicians - 50 x \$50,000	\$0,002,500,000

19)	ISC Program – Fuel Systems & Cryogenic Liquid Storage Systems - Specialists & Technicians - 50 x \$50,000	\$0,002,500,000
20)	ISC Program – Heating / Cooling & Environmental Systems - Specialists & Technicians - 50 x \$50,000	\$0,002,500,000
21)	ISC Program – Atmosphere Processing & Pressure Systems - Specialists & Technicians - 50 x \$50,000	\$0,002,500,000
22)	ISC Program – Human Fecal/Urine Storage & Reclamation Systems - Specialists & Technicians - 50 x \$50,000	\$0,002,500,000
23)	ISC Program – Water Storage & Reclamation Systems - Specialists & Technicians - 50 x \$50,000	\$0,002,500,000
24)	ISC Program – Radar & Sensing Systems - Specialists & Technicians - 50 x \$50,000	\$0,002,500,000
25)	ISC Program – General Factory & Manufacturing - Specialists & Technicians - 50 x \$50,000	\$0,002,500,000
26)	ISC Program – Linen & Uniform & Clothing Manufacturing & Tailoring - Specialists - 50 x \$50,000	\$0,002,500,000
27)	ISC Program – Furniture & Cabinet Manufacturing & Assembly - Specialists & Technicians - 50 x \$50,000	\$0,002,500,000

D - IME/ISC/ISP Program – Astronauts – \$10,800,000

01)	Primary Mission One / A & B Crew – 36 Astronauts – 36 x \$100,000 =	\$0,003,600,000
02)	Primary Mission Two / A & B Crew – 36 Astronauts – 36 x \$100,000 =	\$0,003,600,000
03)	Backup Mission Crew for Mission One & Two A & B Crew – 36 Astronauts – 36 x \$100,000 =	\$0,003,600,000

E - IME/ISC/ISP Program – Astronaut Trainers & Support Specialists – \$3,680,000

01)	Buoyancy Tank Specialist – 1 Master Diver – \$90,000	\$0,000,090,000
02)	Buoyancy Tank Specialist – 8 Divers – 8 x \$50,000	\$0,000,400,000
03)	Nutrition Specialist – 1 MD/PHD – Doctor of Nutrition – \$90,000	\$0,000,090,000
04)	Nutrition Specialist – 4 PHD/MSci – Nutrition Specialist – 4 x \$50,000	\$0,000,200,000
05)	Hygiene Specialist – MD/PHD Doctor of Sports Medicine – \$90,000	\$0,000,090,000
06)	Hygiene Specialist – 4 PHD/MSci Physical Trainer – 4 x \$50,000	\$0,000,200,000
07)	Physical Trainer Specialist – MD/PHD Doctor of Sports Medicine – \$90,000	\$0,000,090,000
08)	Physical Trainer Specialist – 4 PHD/MSci Physical Trainer – 4 x \$50,000	\$0,000,200,000
09)	Medical & Biology Specialist – 1 MD/PHD – Chief Flight Surgeon – \$90,000	\$0,000,090,000
10)	Medical & Biology Specialist – 4 PHD/MSci – Medical Specialist – 4 x \$50,000	\$0,000,200,000
11)	Mental Health Specialist – MD/PHD Doctor of Psychology – \$90,000	\$0,000,090,000
12)	Mental Health Specialist – 4 PHD/MSci Mental Health Specialist – 4 x \$50,000	\$0,000,200,000
13)	Survival & Safety Equipment Specialist – 1 MD/PHD – Doctor of Physiology – \$90,000	\$0,000,090,000
14)	Survival & Safety Equipment Specialist – 4 PHD/MSci – Physiology Specialist – 4 x \$50,000	\$0,000,200,000
15)	Mother Ship Simulator & Systems Trainer Specialist – 1 PHD Chief Engineer – \$90,000	\$0,000,090,000
16)	Mother Ship Simulator & Systems Trainer Specialist – 4 PHD/MSci Engineers – 4 x \$50,000	\$0,000,200,000
17)	Lander/Return Simulator & Systems Trainer Specialist – 1 PHD Chief Engineer – \$90,000	\$0,000,090,000
18)	Lander/Return Simulator & Systems Trainer Specialist – 4 PHD/MSci Engineers – 4 x \$50,000	\$0,000,200,000
19)	Habs/Modules Simulator & Systems Trainer Specialist – 1 PHD Chief Engineer – \$90,000	\$0,000,090,000
20)	Habs/Modules Simulator & Systems Trainer Specialist – 4 PHD/MSci Engineers – 4 x \$50,000	\$0,000,200,000
21)	Rovers/Equipment Simulator & Systems Trainer Specialist – 1 PHD Chief Engineer – \$90,000	\$0,000,090,000
22)	Rovers/Equipment Simulator & Systems Trainer Specialist – 4 PHD/MSci Engineers – 4 x \$50,000	\$0,000,200,000
23)	Space Suit Trainer Specialist – 1 PHD Chief Engineer – \$90,000	\$0,000,090,000
24)	Space Suit Trainer Specialist – 4 PHD/MSci Engineers – 4 x \$50,000	\$0,000,200,000

A + B + C + D - Total For One Year:

\$139,190,000

A+B+C+D E – IME/ISC/ISP Program - 8 Years Of Pre-Mission Design, R&D, Construction – \$139,190,000 x 8 Years =

\$1,113,520,000

F - ISC Program - Mission 1A - 4 Ships – (Mars Equatorial Base 1 of 7) \$1,000,000,000

01)	Crewed (8) - Ship One / Mission 1A - Materials & Consumables –	\$0,250,000,000
02)	Crewed (8) - Ship Two / Mission 1A - Materials & Consumables –	\$0,250,000,000
03)	Cargo - Ship Three / Mission 1A - Materials & Consumables –	\$0,250,000,000
04)	Cargo - Ship Four / Mission 1A - Materials & Consumables –	\$0,250,000,000

G - ISC Program - Mission 1B - 4 Ships (Mars Equatorial Base 2 of 7) – \$1,000,000,000

01)	Crewed (8) - Ship One / Mission 1B - Materials & Consumables –	\$0,250,000,000
02)	Crewed (8) - Ship Two / Mission 1B - Materials & Consumables –	\$0,250,000,000
03)	Cargo - Ship Three / Mission 1B - Materials & Consumables –	\$0,250,000,000
04)	Cargo - Ship Four / Mission 1B - Materials & Consumables –	\$0,250,000,000

H - ISC Program - Facilities & Centers – \$1,000,000,000

01)	Foundry & Metal Fabrication Factory –	\$0,250,000,000
02)	Machining & Manufacturing Factory –	\$0,250,000,000
03)	Final Assembly Factory And Mission Preparation Center –	\$0,250,000,000
04)	Administration / Space Operations / Research & Development - Complex & Centers –	\$0,250,000,000

I - IME/ISC/ISP Program - Launch Infrastructure & Launch Of Ship Components & Consumables Into Earth Orbit -

\$3,657,257,077

01)	International Space Plane (ISP) Program – (1) Space Plane Orbiter First Proof Of Concept Test Prototype:	\$0,130,007,077
02)	International Space Plane (ISP) Program – (1) Space Plane Orbiter First Operational Production Prototype:	\$0,077,250,000
03)	International Space Plane (ISP) Program – (10) Space Plane Orbiters Operational Production Models, Each: 10 x \$50,000,000 =	\$0,500,000,000
04)	Equatorial / Mountain Based / Electromagnetic Assisted Launch System & Operational Infrastructure / Base:	\$1,250,000,000
05)	8 To 10 Years Of Personnel Resources & Talent – Administration / Pilots / Space Crew / Scientists / Specialists / Technicians / Personnel:	\$1,700,000,000

A+B+C+D+E+F+G+H+I - Total IME/ISC/ISP Program Cost (Achievable in 8 to 10 Years) To First Humans On Mars:

\$7,770,777,077

Proprietary Information, Trademark & Copyright Protected, 1986 to 2019, International Space Agency, ISA, United Space Federation, Inc.

1986, 2013, 2019 Proposal – International Mars Exploration (I.M.E.) Program International Space Agency (I.S.A.) – International Space Administration

A. General Information

Project Title:	International Mars Exploration (I.M.E.) Program / Office (of the International Space Agency, ISA)
Brief Project Description:	The I.M.E. Program / Office will, Firstly, On Behalf Of ISA Member Nations & Organizations , will; Promote, Organize, Design, Build, Support, Operate, and Maintain all ISA Infrastructure, Stations, Bases, Facilities, Spacecraft, Aircraft, Vehicles, Machinery, Equipment, Assets, Personnel, Activities, Programs, Projects, and Missions on the Mars Surface & Subsurface, and in Mars Atmosphere & Orbit, and, Secondly, As Approved, To The Peoples Of The World Community, Earth, ISA will; act as an Enabler, Bridge Head, Conduit, and Focal Point for all National Space Agency & Civil/Private: Industrial, Mining, Manufacturing, Commercial, Research & Development, Scientific, Academic, Tourism, and Settlement activities on Mars , in achieving their Non-Military and Peaceful Civilian Objectives and Endeavors, in regards to their own independent Mars activities and endeavors. In General, The ISA , will; “be/act as” the Key Core/Central Administration & Management, Quality Control & TQM Standards, Search & Rescue, Medical & Health Services, Research & Development, Navigations & Communications, and Critical Infrastructure & Assets Umbrella Organization on the Mars Surface & Subsurface, and in the Mars Atmosphere & Orbit . The ISA will provide the Core/Central Infrastructure, Personnel, and Operations on the Surface, Subsurface, Atmosphere, and In Orbit Around, Mars , and all End Users will provide independently, or approved to be contracted through ISA networks, all support services, materials, personnel, consumables, and equipment for independent activities outside the Direct Control or Charter/Treaty of ISA . It is highly advised, that no Earth Government be allowed to have Military or Sovereign control of Mars , like is Presently The Established Treaty Protocol In Antarctica .
Prepared By:	Admiral, Rick R. Dobson, Jr., Chairman & CEO, International Space Agency, “Redacted/Proprietary – ISA Personnel”
Date:	Cir. June 1986– Original Proposal / 20 October 2013 - Updated & Republished / 3 May 2019 – Updated & Republished

B. Project Objectives:

PURPOSE: The **International Mars Exploration (I.M.E.) Program / Office** will function as the Core/Central Specialized Knowledge & Expertise Base and Focal Point of Excellence & Standards for all of **Mars Infrastructure, Operations, Projects, Missions, and Programs of International Space Agency**. It will be the Key Initiator, Enabler, Conduit, Promoter, and Organizational Instrument for all endeavors specifically related to the exploration, utilization, and human settlement & activities of **Mars**. This will include (but is not limited to) coordination of the mapping of **Mars Surface** (initially planning robotic lunar rovers, Aircraft, and Satellites to map **Mars**, Google Maps is a good example of what **ISA** should be looking to achieve.) to identify suitable landing sites, and possible locations for **Mars Bases and Facilities**, planning and execution of a **Mars Orbital Space Station and Space Craft “Infrastructure”** to shuttle Personnel, Supplies, Materials, and Equipment from the **Mars Orbit “to/from” Mars Surface**; and various Surface and Subsurface activities and facilities on **Mars**.

Areas of Operations, Programs, and Missions Authority:

- Building a Knowledge & Expertise Base related to all things required for the Exploration, Utilization, and Human Settlement of Mars.
- Researching & Planning Most Effective & Best Possible Locations to Enable Landings, Launch, and Surface/Subsurface Activities.
- **Explore Possible Transportation Systems “from/to”: Mars to Earth / Mars to Luna / Mars to Solar System**
 - Conventional Chemical Propulsion/Power Technologies / Nuclear “Fission & Fusion” Propulsion/Power Technologies
 - Ion Thrusters Propulsion Technologies / Solar Cell Based Propulsion/Power Technologies
 - Hybrid, Non-Conventional, and Closed Loop Propulsion/Power Technologies
- **Explore Possible Transportation Infrastructure and Systems “from/to”: Mars Surface to Mars Orbit**
 - Conventional Chemical Propulsion/Power Technologies / Nuclear “Fission & Fusion” Propulsion/Power Technologies
 - Ion Thrusters Propulsion Technologies / Solar Cell Based Propulsion/Power Technologies
 - Hybrid, Non-Conventional, and Closed Loop Propulsion/Power Technologies
 - Electromagnetic Rail Launch & Recovery Systems, Mechanical Leverage Launch, Equatorial Space Elevator
- Soliciting & Selection of Suitable Government & Private End Users & Costumers for Robotic & Human Exploration & Activities
- Design of suitable spacecraft, aircraft, vehicles, and equipment for Robotic & Human Exploration & Activities
- **Design and Planning of Suitable Structures, Buildings, Facilities, and Utilities on the Surface & Subsurface**
 - Personnel Living Quarters / Tourist & Hotel Accommodations / Special Purpose Accommodations & Facilities
 - Suitable Structures & Facilities to support a wide range of working and living requirements on the Surface & Subsurface.
 - Environmental structures & buildings to grow food and keep animal livestock for consumption, store & process water & waste.
 - Structures & Facilities to House: Environmental & Atmosphere, Heating & Cooling, Water & Waste, Systems & Infrastructure.
 - Structures & Facilities to House: Commercial & Industrial, Scientific & Research, Academic & Training, Infrastructure.
 - Structures & Facilities to House: Power Systems, Navigations Systems, Communications Systems, and Computer Systems.
 - Structures & Facilities to House: Medical & Health Services, Search & Rescue Services, and Security & Judicial Services
- Initial explorers will require laboratories in which to experiment with life support systems to enable humans to live on **Mars**, and the Primary Focus of Materials & Personnel will be on Construction & Natural Resources Exploration & Utilization.

BENEFITS: The **International Mars Exploration (I.M.E.) Program / Office** will be the Core/Center of Specialized Knowledge, Expertise, Excellence, Standards, Personnel, Space Stations, Spacecraft, Vehicles, Equipment, Structures, Bases, Facilities, Programs, Projects, Missions, and Human Activities In Orbit, On The Surface, and Under The Surface, able to supply its Infrastructure, Resources, and Operations to National “Government & Civil” and Private Space Exploration Agencies, Organizations, Companies, Institutions, Foundations, Societies, and Private Individuals. Enabling them to Benefit Symbiotically, Collectively, and Co-Operatively on the Promotion, Planning, Building, Operation, and Maintenance of a Robust, Extensive, and Long Duration Transportation & Support Infrastructure of **Scale & Scope “Out Side The National Domain Or Capability”**, which is easily accessed, with all costs optimized, and enhanced and rapid technology development. The **(I.M.E.) Program** will work very closely with, and in tandem, with the **(I.L.E.) Program, (I.S.E.) Program, and (I.S.P.) Program** as all elements of these **KEY ISA Programs**, will collectively depend on each others existence to ensure overall broad **ISA** program operation, advances, and longevity.

FUNDING: Costs for all International Space Agency infrastructure & operations on **Mars**, will be obtained primarily through a pay for use strategy “**Toll or Fee**” by all end users, whether they be National Governments or Non-Governmental Entities, Organizations, or Persons; and, augmented by approved Multi-National & Joint Programs Participants, Government & Private Grants, and Private Philanthropy. A proposed initial amount of **(\$7 Billion)** U.S. Dollars is sought for **IME Program** start up funding, for perpetual operations of the **ISA IME Program**.

Proprietary Information, Trademark & Copyright Protected, 1986 to 2019, International Space Agency, ISA / United Space Federation, Inc.

1986, 2013, 2019 Proposal – International Luna Exploration (I.L.E.) Program International Space Agency (I.S.A.) – International Space Administration

A. General Information

Project Title:	International Luna Exploration (I.L.E.) Program / Office (of the International Space Agency, ISA)
Brief Project Description:	The I.L.E. Program / Office will, Firstly, On Behalf Of ISA Member Nations & Organizations , will, Promote, Organize, Design, Build, Support, Operate, and Maintain all ISA Infrastructure, Stations, Bases, Facilities, Spacecraft, Aircraft, Vehicles, Machinery, Equipment, Assets, Personnel, Activities, Programs, Projects, and Missions on the Luna Surface & Subsurface , and in Luna Atmosphere & Orbit ; and, Secondly, As Approved, To The Peoples Of The World Community, Earth, ISA will; act as an Enabler, Bridge Head, Conduit, and Focal Point for all National Space Agency & Civil/Private: Industrial, Mining, Manufacturing, Commercial, Research & Development, Scientific, Academic, Tourism, and Settlement activities on Luna , in achieving their Non-Military and Peaceful Civilian Objectives and Endeavors, in regards to their own independent Luna activities and endeavors. In General, The ISA , will; “be/act as” the Key Core/Central Administration & Management, Quality Control & TQM Standards, Search & Rescue, Medical & Health Services, Research & Development, Navigations & Communications, and Critical Infrastructure & Assets Umbrella Organization on the Luna Surface & Subsurface , and in Luna Orbit . The ISA will provide the Core/Central Infrastructure, Personnel, and Operations on the Surface, Subsurface, Atmosphere, and In Orbit Around, Luna , and all End Users will provide independently, or approved to be contracted through ISA networks , all support services, materials, personnel, consumables, and equipment for independent activities outside the Direct Control or Charter/Treaty of ISA . It is highly advised, that no Earth Government be allowed to have Military or Sovereign control of Luna , like is Presently The Established Treaty Protocol In Antarctica .
Prepared By:	Admiral, Rick R. Dobson, Jr., Chairman & CEO, International Space Agency, “Redacted/Proprietary – ISA Personnel”
Date:	Cir. June 1986– Original Proposal / 20 October 2013 - Updated & Republished / 3 May 2019 – Updated & Republished

B. Project Objectives:

PURPOSE: The **International Luna Exploration (I.L.E.) Program / Office** will function as the Core/Central Specialized Knowledge & Expertise Base and Focal Point of Excellence & Standards for all of **Luna Infrastructure, Operations, Projects, Missions, and Programs of International Space Agency**. It will be the Key Initiator, Enabler, Conduit, Promoter, and Organizational Instrument for all endeavors specifically related to the exploration, utilization, and human settlement & activities of **Luna**. This will include (but is not limited to) coordination of the mapping of **Luna Surface** (initially planning robotic lunar rovers and Satellites to map **Luna**, Google Maps is a good example of what **ISA** should be looking to achieve.) to identify suitable landing sites, and possible locations for **Luna Bases and Facilities**, planning and execution of a **Luna Orbital Space Station and Space Craft “Infrastructure”** to shuttle Personnel, Supplies, Materials, and Equipment from the **Luna Orbit “to/from” Luna Surface**; and various Surface and Subsurface activities and facilities on **Luna**.

Areas of Operations, Programs, and Missions Authority:

- Building a Knowledge & Expertise Base related to all things required for the Exploration, Utilization, and Human Presence on **Luna**.
- Researching & Planning Most Effective & Best Possible Locations to Enable Landings, Launch, and Surface/Subsurface Activities.
- **Explore Possible Transportation Systems “from/to”:** **Luna to Earth / Luna to Mars / Luna to Solar System**
 - Conventional Chemical Propulsion/Power Technologies / Nuclear “Fission & Fusion” Propulsion/Power Technologies
 - Ion Thrusters Propulsion Technologies / Solar Cell Based Propulsion/Power Technologies
 - Hybrid, Non-Conventional, and Closed Loop Propulsion/Power Technologies
- **Explore Possible Transportation Infrastructure and Systems “from/to”:** **Luna Surface to Luna Orbit**
 - Conventional Chemical Propulsion/Power Technologies / Nuclear “Fission & Fusion” Propulsion/Power Technologies
 - Ion Thrusters Propulsion Technologies / Solar Cell Based Propulsion/Power Technologies
 - Hybrid, Non-Conventional, and Closed Loop Propulsion/Power Technologies
 - Electromagnetic Rail Launch & Recovery Systems, Mechanical Leverage Launch, Equatorial Space Elevator
- Soliciting & Selection of Suitable Government & Private End Users & Costumers for Robotic & Human Exploration & Activities
- Design of suitable spacecraft, aircraft, vehicles, and equipment for Robotic & Human Exploration & Activities
- **Design and Planning of Suitable Structures, Buildings, Facilities, and Utilities on the Surface & Subsurface**
 - Personnel Living Quarters / Tourist & Hotel Accommodations / Special Purpose Accommodations & Facilities
 - Suitable Structures & Facilities to support a wide range of working and living requirements on the Surface & Subsurface.
 - Environmental structures & buildings to grow food and keep animal livestock for consumption, store & process water & waste.
 - Structures & Facilities to House: Environmental & Atmosphere, Heating & Cooling, Water & Waste, Systems & Infrastructure.
 - Structures & Facilities to House: Commercial & Industrial, Scientific & Research, Academic & Training, Infrastructure.
 - Structures & Facilities to House: Power Systems, Navigations Systems, Communications Systems, and Computer Systems.
 - Structures & Facilities to House: Medical & Health Services, Search & Rescue Services, and Security & Judicial Services
- Initial explorers will require laboratories in which to experiment with life support systems to enable humans to live on **Luna**, and the Primary Focus of Materials & Personnel will be on Construction & Natural Resources Exploration & Utilization.

BENEFITS: The **International Luna Exploration (I.L.E.) Program / Office** will be the Core/Center of Specialized Knowledge, Expertise, Excellence, Standards, Personnel, Space Stations, Spacecraft, Vehicles, Equipment, Structures, Bases, Facilities, Programs, Projects, Missions, and Human Activities In Orbit, On The Surface, and Under The Surface, able to supply its Infrastructure, Resources, and Operations to National “Government & Civil” and Private Space Exploration Agencies, Organizations, Companies, Institutions, Foundations, Societies, and Private Individuals. Enabling them to Benefit Symbiotically, Collectively, and Co-Operatively on the Promotion, Planning, Building, Operation, and Maintenance of a Robust, Extensive, and Long Duration Transportation & Support Infrastructure of **Scale & Scope “Out Side The National Domain Or Capability”**, which is easily accessed, with all costs optimized, and enhanced and rapid technology development. The **(I.L.E.) Program** will work very closely with, and in tandem, with the **(I.M.E.) Program, (I.S.E.) Program, and (I.S.P.) Program** as all elements of these **KEY ISA Programs**, will collectively depend on each others existence to ensure overall broad **ISA** program operation, advances, and longevity.

FUNDING: Costs for all International Space Agency infrastructure & operations on **Luna**, will be obtained primarily through a pay for use strategy “**Toll or Fee**” by all end users, whether they be National Governments or Non-Governmental Entities, Organizations, or Persons; and, augmented by approved Multi-National & Joint Programs Participants, Government & Private Grants, and Private Philanthropy. A proposed initial amount of **(\$3 Billion)** U.S. Dollars is sought for **ILE Program** start up funding, for perpetual operations of the **ISA ILE Program**.

**1988 / 2005 / 2017 / 2019 Proposal - Operational & Programs Charter For The
 “International Space Plane (ISP) Program” -and-
 “Electromagnetic Assisted Space Launch (EASL) System”**

A. General Information

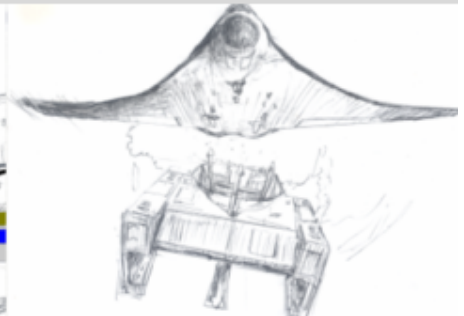
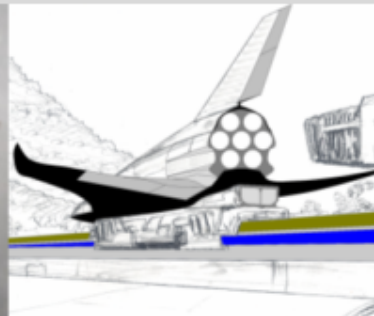

<i>Project Title:</i>	<i>International Space Plane (ISP) Program - & Electromagnetic Assisted Space Launch (EASL) System</i>
<i>Brief Project Description:</i>	The International Space Plane (ISP) Program, which was started in 1988 by the International Space Agency (ISA) at Cornell University in Ithaca, New York State, in the United States, and is based on the work of the Father of the Rocket Age and Designer of the Apollo Moon Rockets, Dr. Werner von Braun, and is presently looking for a Mountain Launch site on the Earths Equator, and most specifically in Brazil. The ISP Program has its conceptual roots in, Ref1: “Silver Bird” WW2 German Space Plane & Assisted Launch System.; Ref2: 1952 Movie “When Worlds Collide” in which the work of Werner von Braun and NASA where show cased. Of course these earlier designs used “Rocket Sleds” to achieve first stage assisted launch, but in the (ISP) Program more powerful and modern application of Electromagnetic Repulsor “Rail Gun” Technology is used to achieve first stage assisted launch. <i>54 page detailed thesis paper is included with this condensed proposal synopsis.</i>
<i>Prepared By:</i>	Dr. Alexander Bolonkin – Russia / United States Member, Board of Directors -&- Chief Science Officer (CSO) , International Space Agency, ISA Director , International Space Plane (ISP) Program, International Space Administration Admiral, Rick R. Dobson, Jr. - United States Chairman, Board of Directors , CEO, Founder , International Space Agency, ISA Assistant Director , International Space Plane (ISP) Program, International Space Administration Mr. Robert D. McGown, MSci - United States Member, Board of Directors , International Space Agency, ISA Director, International Mars Programs Office , International Space Administration Advisor , International Space Plane (ISP) Program, International Space Administration <i>2005 / 2017 - Advisor & Contributor - Dr. Kenneth House, Scientist & Meglev Systems Researcher, NASA, United States</i> <i>2002 / 2006 - Advisors & Contributors - Mr. Jerald Schneider, PE, SE - United States -and-</i> <i>Mr. Vadim Makarov, PE, SE - Russia / United States -and- Dr. David Maker, Scientist - United States</i>
<i>Date:</i>	ISP Concept Work Completed 11 June 1988, Re-Released 17 May 2005, Re-Released 1 May 2017

B. Project Objectives:

<p>PURPOSE: The International Space Plane (ISP) Program Is Based On 5 Basic Principles.</p> <ol style="list-style-type: none"> 1) “Ballistic & Non-Aerodynamic Lifting Vehicles” which are designed as Disposable (<i>Expendable</i>) Launch Vehicles are not efficient; waste large amounts of precious materials and human resources; and present a space debris hazard in Earths Orbit (<i>Orbiting Debris</i>) and on the Earths Surface (<i>Reentry Debris</i>). SpaceX and its so called reusable boosters are a money mill that leads to a dead end, and will never achieve RLW/SSTO. 2) Using <i>EXTERNAL</i> energy sources not carried on (<i>in</i>) a space launch vehicle increases the launch vehicles fuel efficiency and cargo carrying capability, (<i>Assisted Launch</i>), and applies “First Stage” Launch Velocities “Or Substantial Part Of” Single Stage To Orbital Insertion Velocities. 3) A totally reusable one-vehicle architecture is most cost, materials, and labor effective & operationally sound strategy to employ in a space launch vehicle. <i>Launch Return “LR”- Reusable Space Vehicle “RSV”- Single Stage To Orbit “SSTO” – Aerodynamic Lifting Body “ALB”</i> 4) Utilizing Earths atmosphere for aerodynamic lift and braking, and Oxygen (<i>O2</i>) for propulsion, will increase the space launch vehicles efficiency and capabilities. Strategically Launching from the Earths Equator will also add free launch to orbital velocity to any launch vehicle. 5) Creating a <i>NEW</i> launch philosophy, systems, technologies that will allow for wide range of mission requirements & capabilities with out numerous, repetitive, costly, wasteful redesign and reconfiguration. In effect, the system employed in an Aircraft Carrier for Launching Aircraft of varying Types, Weights, Capabilities; except the (ISP) Assisted Launch System would be scaled up and more sophisticated technologically. <p>CAPABILITY: Specific Areas of Mission & Operations & Management Authority:</p> <ul style="list-style-type: none"> • Airbus Industries Management and Manufacturing Model Applied to the ISP Program, with Pay Per Launch Funding Strategy • Launch Goal of 3 to 7 Launches Per Day Capability (1095 to 2555 Launches Per Year) Manned & Unmanned Operations • Totally 100% Reusable Launch Vehicle and Robust Ground Assisted Launch System, “No Waste of Materials or Labor”. <p>BENEFITS: Cheap, Routine, Robust, and Safe Access to Earth Orbit, in a Program of Sufficient Scope & Scale to Insure Longevity.</p> <p>FUNDING: A Single or Combined Grant or Donation in the sum of \$7 Million U.S. Dollars is sought, to fund a “Start Up” Perpetual Research, Development, and Operations Program, to obtain/secure key Scientific, Engineering, Flight Personnel, Facilities, Equipment, and Materials required to build, organize, and operate an International Space Plane (ISP) Program.</p>

INTERNATIONAL SPACE AGENCY
INTERNATIONAL SPACE PLANE PROGRAM

45° T-1 023
45° S-B 038
45° A-0 050

2G to 3G ~ Assisted Launch Acceleration at 45 Deg to 60 Deg at 4 to 7 Miles at 8000 to 10,000 Feet ~ Height Base to Top at 1,500 MPH ~ Release Top at 851.3 MPH ~ Start Run Base

45 Deg Angle
1/4 Mile to 1/2 Mile Transition Arch

PROPOSED MOUNTAIN LAUNCH SITE IN BRAZIL

International Space Agency (ISA) Names, Public Identity, Emblems, Logos, Concept, Materials Are United States Government (S) Trademark (TM) (C) Copyright (C) - 1996 - 2012. All Rights Reserved (Est. 1962). Founded in 1960. Incorporated in 1990 (S&FC-3 New York State Non-Profit Corporation)

INTERNATIONAL PLANET / MOON (ASTEROID) LAUNCHER / LANDER PROGRAM
SURFACE TO ORBIT - LAUNCHERS / ORBIT TO SURFACE LANDERS
HAB MODULES LANDERS / CARGO MODULES LANDERS

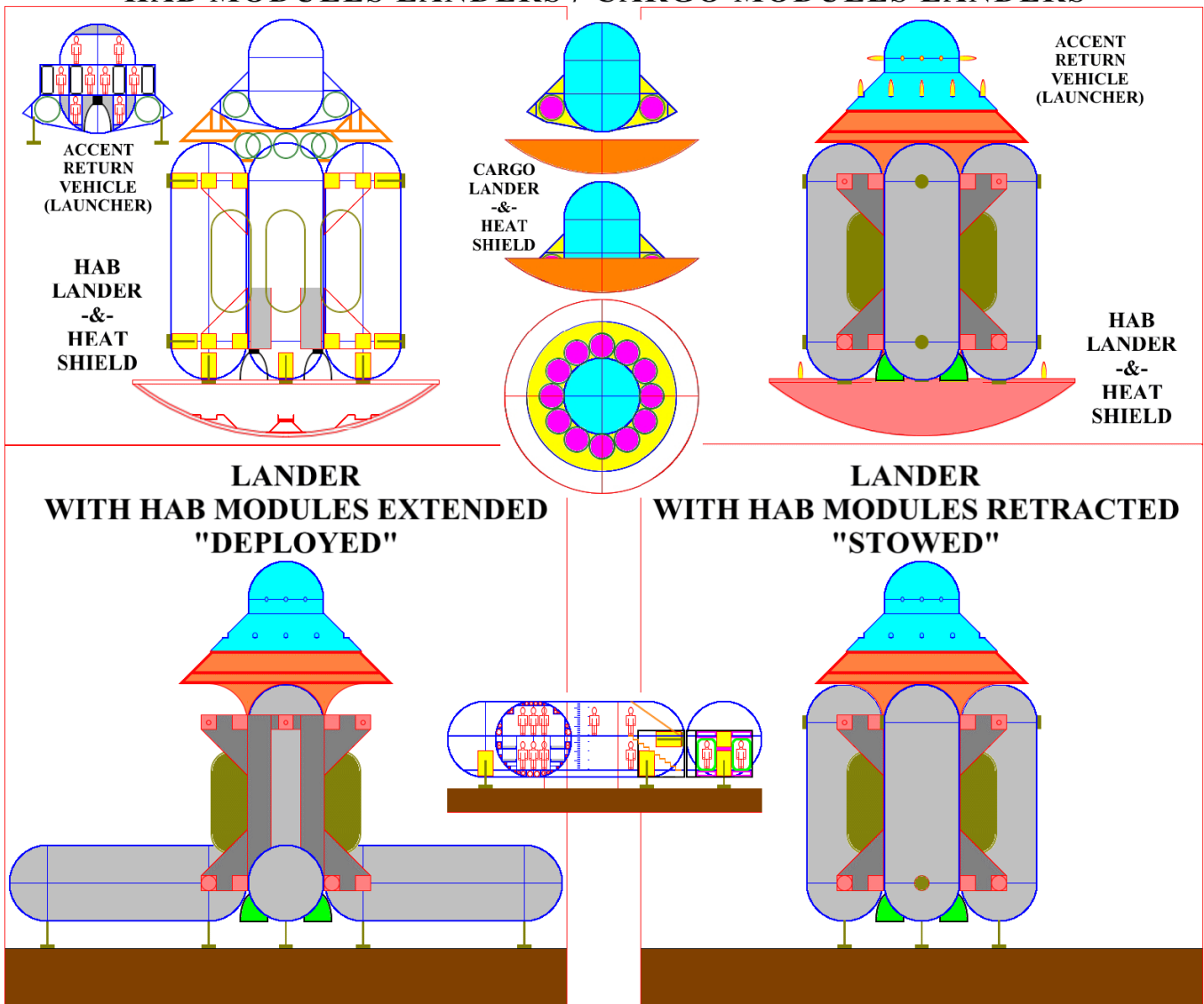

INTERNATIONAL SOLAR CRUISER PROGRAM NUCLEAR POWERED INTER-PLANETARY SHIPS

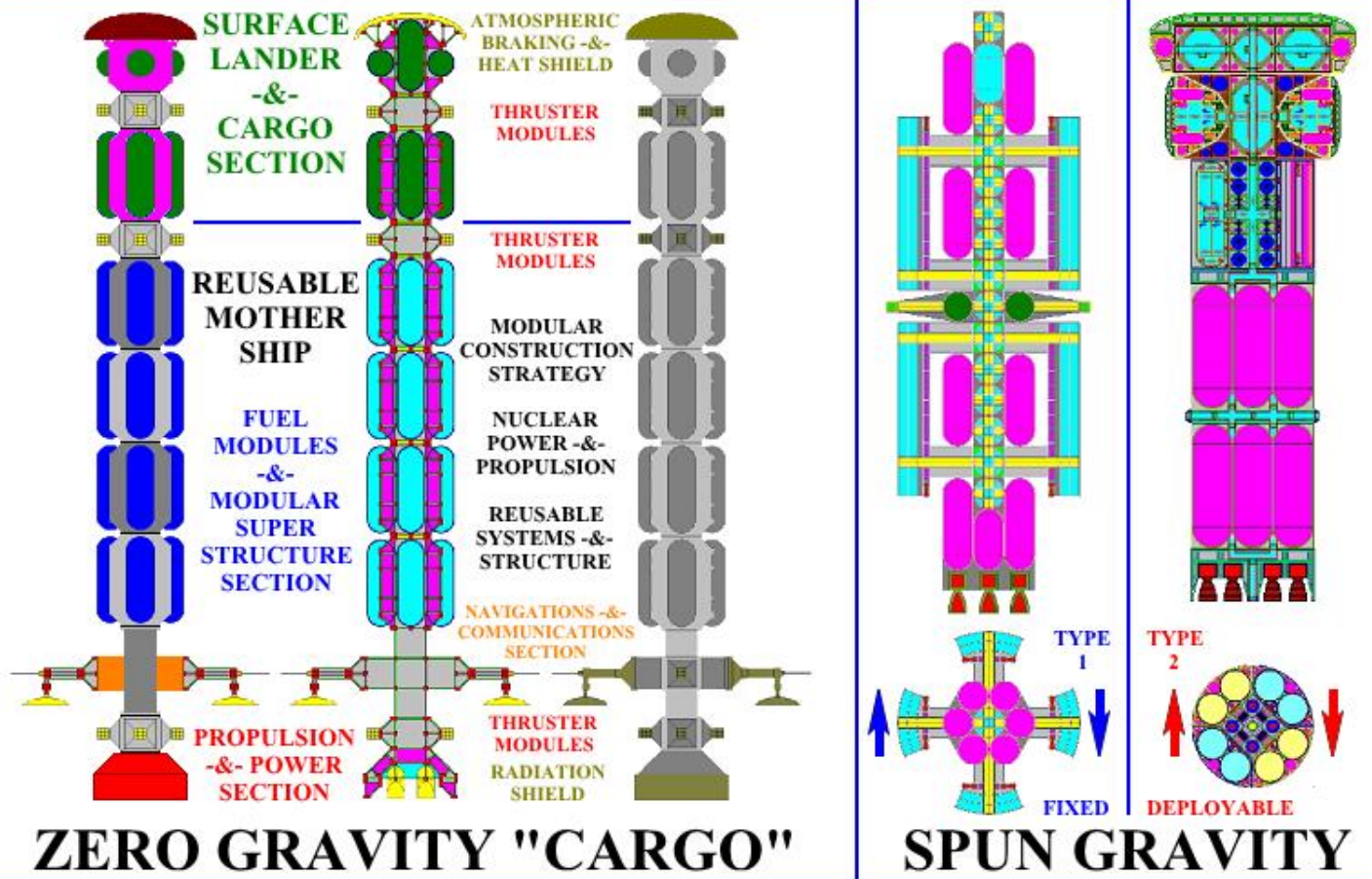
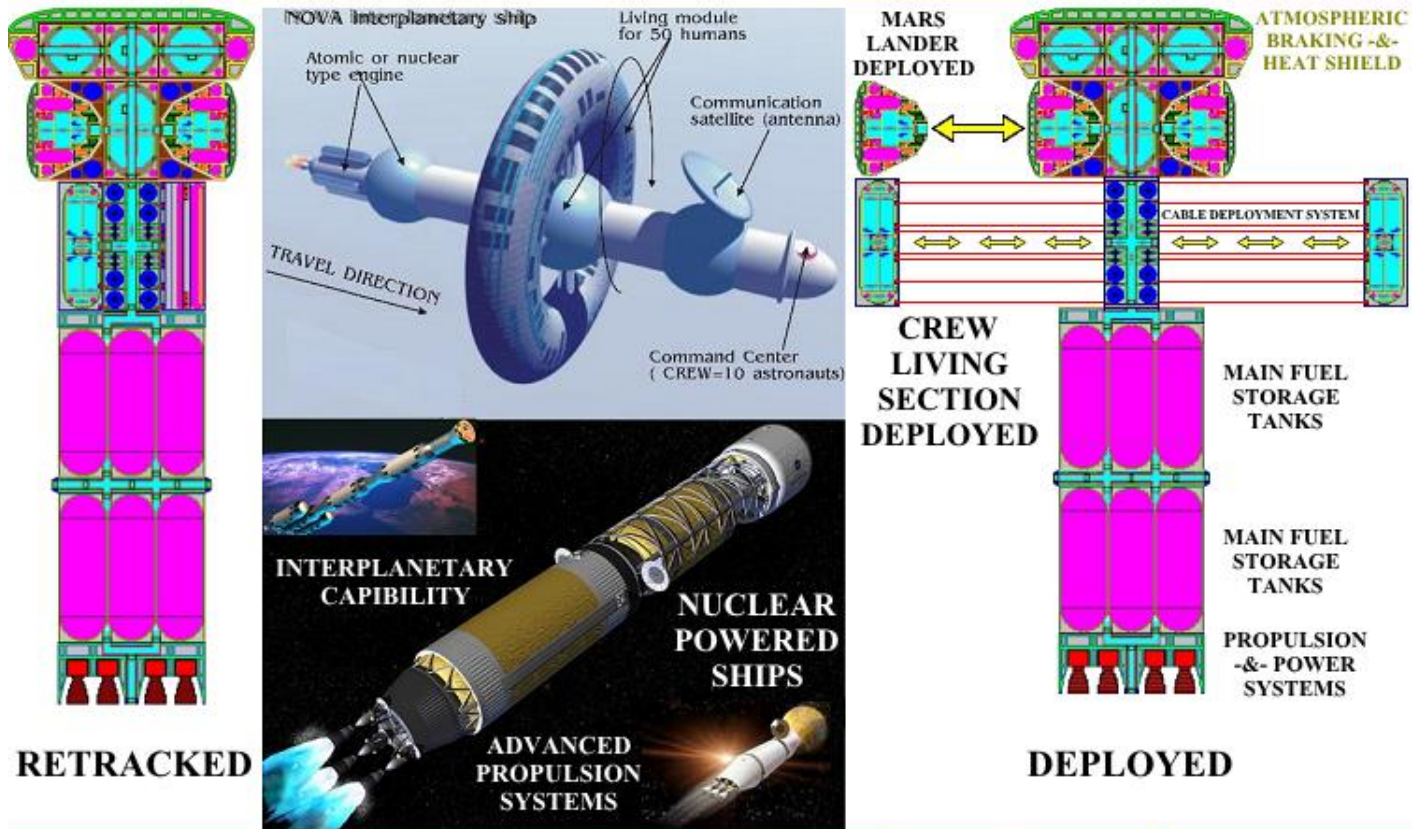



International Space Agency - I.S.A. International Space Administration

PURPOSE: The International Space Station (I.S.S.) Program / Office will function as the Core/Central Knowledge and Expertise Base and Focal Point of Excellence and Standards for all Earth Orbital Manned: Facilities, Stations, Operations, Programs, Projects, and Missions of the International Space Agency, I.S.A.. It will be the Key Initiator, Enabler, Conduit, Promoter, and Organizational Instrument for all endeavors specifically related to Manned Facilities & Stations in Earths Orbit. This will include (but is not limited to) Planning, Establishing, and Operation of Artificial "Spun" Gravity and Micro-Gravity Orbital Space Facilities for Space Craft & Station Construction in Earths Orbit, Fuel & Materials Storage in Earths Orbit, Earth Remote Censing & Communication Infrastructure in Earths Orbit, Stations and Space Craft "Support Infrastructure" to Shuttle Personnel, Supplies, Materials, and Equipment "to" & "from" Earth Orbit from the Earths Surface, and To Points Beyond Earths Orbit, such as Planets/Moons/Asteroids, and Interstellar Space.

INTERNATIONAL SPACE STATION (I.S.S.) PROGRAM

"SPUN" ARTIFICIAL GRAVITY STATIONS / MICRO "0" GRAVITY STATIONS / FUEL SUPPLY FACILITIES
ORBITAL SHIP YARDS -AND- MANUFACTURING FACILITIES / LARGE SPACE STRUCTURES "COLONIES"

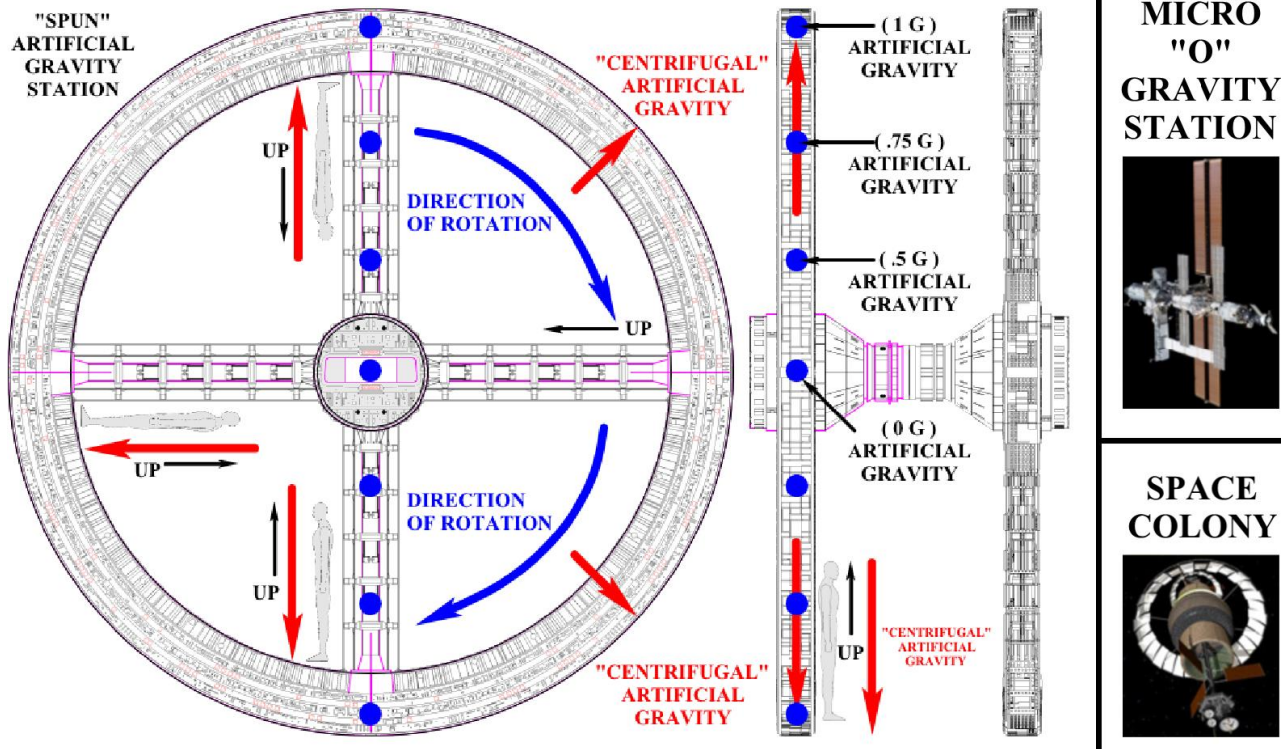
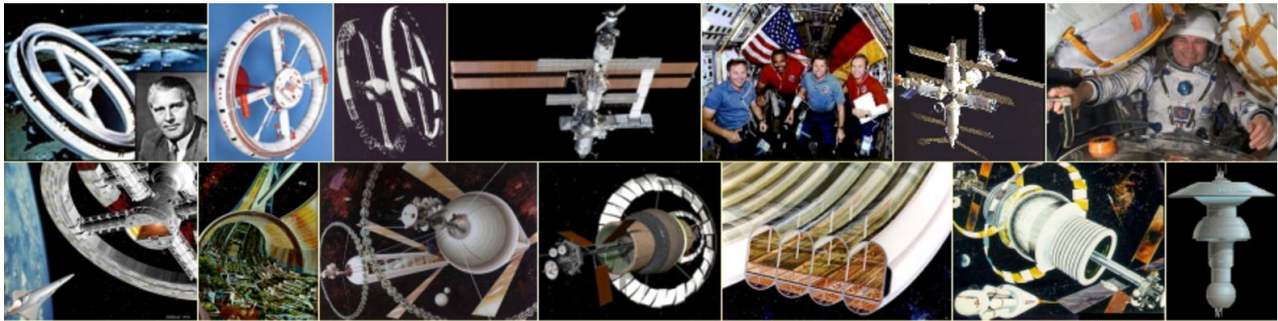

2013 Proposal - Operational & Programs Charter For The "International Super Computer Center & Program Office" (I.S.C.C.P.O)

A. General Information



Project Title:	International Super Computer Center & Program Office (I. S. C. C. P. O)
Brief Project Description:	The ISCCPO will support and maintain a secure central international space sciences, astronomy, and space technology data base, and advanced computer simulation capabilities for advanced International Space Agency, ISA, and international, space technology programs, projects, missions, and advanced international space research & development activities.
Prepared By:	Mr. William Kraemer - United States Director , International Super Computer Center & Program Office, International Space Agency, ISA Mr. Joshane Kelsy - India Assistant Director , International Super Computer Center & Program Office, International Space Agency, ISA Mr. Rick R. Dobson, Jr. - United States - Chairman, CEO, Founder , International Space Agency, ISA
Date:	4th of October, 2013

B. Project Objectives:

PURPOSE: The **International Super Computer Center & Program Office (ISCCPO)** will function as an important operational division, center, and program office of "**International Space Agency, ISA**" and will be a catalyst & enabler to facilitate & support all research & development, and space technology programs, and the central management of Computing Capabilities & Services and Supercomputer Facilities & Hardware that will be directly or indirectly supporting the vision and mission of the International Space Agency Organization; and its Operational Divisions, Departments, Centers, and Commands. **ISCCPO** will also be the command & control authority of the **International Super Computer Facility (ISCF)** and **International Super Computer Program Office (ISCP)**, and will include the collective personnel resources of **ISCCPO** Officers, Management, Technicians, and Personnel.

CAPABILITY: Specific Areas of Mission & Operations & Management Authority:

- Data Computing & Storage for Global Space Technology, Space Science's, Astronomy, and ISA Operations
- International Data & Computing Collaboration, Cooperation, and Joint Efforts, byfor ISA Member States & Organizations
- Cost Savings & Resource Preservation through Utilization of a Central International Data Base, Software, Hardware, and Facility
- Central & Secure Virtual Operating Environment, Database's & Archive's, and Management & Personnel
- Central International Database & Archive's, Simulation's & Calculation's Processing, Hardware & Facilities.
- Verbal & Digital Multi-Language Interface Capabilities "Voice Commands & Teletype/Keyboard & Digital"
- Language Translation Capability "Universal Translator System"
- Advanced State Of The Art - Data Storage Systems, User Friendly Program "Software" Architecture, Computer/Human Interfaces
- Advanced Scientific & Technology Simulations & Calculations Capabilities
- Advanced Display & 3D Projection Systems and Virtual Reality Capabilities
- Dedicated Point to Point Laser, Microwave, and Satellite Communications Network to International Space Agency Infrastructure.
- Hardened & Secure Deep Underground Facility for Housing All Primary ISCCPO Data, Software, Equipment, and Personnel
- Research & Development of Artificial Intelligence Systems and Durable Computer Systems Suitable for Space Environments

BENEFITS: The **ISCCPO** will ensure the smooth functioning of the **ISCF** Program & **ISCO** Operations, and will streamline & combine many selected & approved international, multi-national, and national space science & technology data bases & archives into one unified and easy to access and use international data base & archive. The **ISCCPO (ISCF & ISCO)** Project will create a "**First Of Its Kind**", permanent & secure International Super Computer Facility & Database and Archive's, with Dedicated Staff, to maintain International Space Agency and selected, approved, and authorized international space technology & scientific databases & archives, and to provide advanced simulation & computing ability for the International Space Agency Organization and international space technology & scientific research & development programs. Security, both physical & systems operations, will protect **ISCF** databases & archives, and allow the information to be segregated or shared as the International Space Agency, and **ISCF**, Member Nations, NGO's, and Data Originator's may so desire or authorize, or as jointly approved. The benefits to the advancement of scientific knowledge of space, and the opening & utilization of the space frontier by humanity, as a result of the success of the **ISCF** project will be tremendous, and will surely become an invaluable resource to Humanity of Earth.

FUNDING: A Single or Combined Grant or Donation in the sum of Seven Million U.S. Dollars (\$ 7,000,000) is sought, to fund a "Start Up" Perpetual Research, Development, and Operations Program, to obtain/secure key Scientific, Engineering, Computer Personnel, Facilities, Equipment, and Materials required to build, organize, and operate an **International Super Computer Facility & Program**.

2013 Proposal - Operational & Programs Charter For The *“International Space Academy (The Space Academy)”* -and- *“International Space Agency Training Programs”*

A. General Information



International Space Academy

Project Title:	International Space Academy “The Space Academy”
Brief Project Description:	The International Space Academy "The Space Academy" Is An Academic, Physical Fitness, and Leadership Training Institution, Which Has A Primary Function Of Providing Highly Trained And Capable Space Operations, Scientific, Technical Leaders And Personnel To The International Space Agency, And Its Member States And Organizations; And As A Secondary Function, To Operate As An Academic Training "University" Institution To The Global Space Community And Global Space Sectors. The International Space Academy "The Space Academy" Is A Division Of The International Space Agency Organization.
Prepared By:	Mr. Rick R. Dobson, Jr. - United States - Chairman, CEO, Founder, International Space Agency
Date:	4th of October, 2013

B. Project Objectives:

PURPOSE: To Educate, Train, and Prepare the Future International Leaders, Space Personnel, and Global Society, for the Exploration, Development and Colonization of our Solar System, and the Infinite Spaces of the Next Great Human Frontier, SPACE.

CAPABILITY: Specific Areas of Mission & Operations & Management Authority:

The International Space Academy will Provide to the Member Nations and Organizations of the International Space Agency, and its Agents, Contractors, and Approved Individuals; Entrance into the Following Academic and Training Programs :

- International Space Academy – Administration, Professors, and General Staff
- 2, 4, 6 year - Training Programs – International Space Academy "Commissioned Officers – Officer Cadets" Officer Training
- 2, 4, 6 year - Training Programs – International Space Academy "Non-Commissioned Officers - NCO Cadets" NCO Training
- 2, 4, 6 year - Training Programs – International Space Academy "Enlisted Personnel - Recruits" Enlisted Training
- 2, 4, 6 year - Training Programs – International Space Agency "Internal Personnel Training Programs"
- 2, 4, 6 year - University Courses & Classes: (Diplomatic) , (International Space Agency Private) , (The General Public)
- University & College & High School : (Summer Camps & Special Programs For Young Adults & Youth)
- To Support, Host, and Enable International Space Conferences, Meetings, and Events.
- Seek Support From: National Naval Academies Programs Globally "Submarine Communities In Particular", National Space Agency Astronaut/Cosmonaut Training Programs Globally, and Private Commercial Payload & Technology Programs Globally, which will be sought out for Assistance, Support, Collaboration, Cooperation, and Joint Training & Operations Endeavors
- To engage and network with Universities, Colleges, Academic Institutions, and Scientific & Research Organizations Globally.

BENEFITS: To Provide Highly Trained And Capable Space Operations, Scientific, Technical Leaders And Personnel To The International Space Agency, And Its Member States And Organizations; And As A Secondary Function, To Operate As An Academic Training "University" Institution To The Global Space Community, Global Space Sectors, and the General Public.

FUNDING: A Single or Combined Grant or Donation in the sum of Three Million U.S. Dollars (\$ 3,000,000) is sought, to fund a "Start Up" Perpetual Space Sector Academic Training Academy and Programs, and Administrative and Educational Operations, and to obtain/secure key Space Technology, Science, and Administration Educators; and Academic, Technical, Language, Physics, Mathematics, Scientific, Engineering, Computer, Physical Fitness, and numerous other specialties, disciplines, and fields Professors, Administrators, Personnel, as well as Facilities, Equipment, and Materials required to build, organize, and operate an **International Space Academy and Programs**. This funding will provide the initial Main Facilities & Property, and Staffing & Operations for 2 to 3 years start up, thereafter, Cadet & Student Fees, Conference & Meeting Fees, and Research Grants will fund ongoing operations.

International Space Agency, Proprietary Information, Trademark & Copyright Protected, 1986 to 2019, All Rights Are Reserved

~ Primary International Space Agency (ISA) – International Mars Exploration – Goals, Objectives, Priorities ~

2 Duplicate Mars Mission Sets are each made up of 8 Fully Reusable Space Craft utilizing Nuclear & Ion & Conventional – Main Propulsion & Thrusters & Power *All 8 ships will have identical main structures and primary systems (Modular Profiles & Construction) **Note:** This is done to streamline manufacturing, assembly, maintenance, and operations, and in the case of a mission accident or emergency the components and systems of all ships will be identical and interchangeable. The program goal is to establish 7 outposts equally spaced out around the Mars Equator, with each outpost having a geostationary satellite positioned directly overhead. The equally spaced outposts along the Mars Equator will allow the land rovers to transit between the equatorial outposts, giving access to a large percentage of the Mars Surface. The geostationary satellites also equally positioned around the equator of Mars, will establish a communications relay and satellite navigations system that will have near total real time access to the entire surface of Mars, and will bridge all the equatorial outposts together, as well linking Mars-Earth-Luna communications unobstructed by Mars planetary rotation. These geostationary satellites will also give ships coming from Earth-Luna precise navigations information as they approach Mars for orbital insertion, as well navigational information as they break Mars Orbit to return to Earth-Luna. Also, North and South Pole Outposts will be established, with precisely placed communications and navigations beacons that will be positioned exactly on the Mars Rotational Axis. A primary purpose of the polar outposts, will be to access frozen water resources to be transported to the equatorial outposts for use in the form of liquid water. A high priority program for the Mars Equatorial Outposts, will be to conduct surface core drilling all along the Mars Equator between the Equatorial Outposts, to identify the geologic make up and structure of the subsurface strata of Mars in order to identify minerals, ores, and resources that can be used for civil engineering and manufacturing, as well to identify any subsurface water resources that may exist and be utilized. Also subsurface bedrock and mountain & canyon geologic sites will be sought out and identified, in which tunneling/mining technology can be utilized to carve out sub-surface tunnels to be sealed and pressurized for use as living space, agricultural space, and industrial and manufacturing space. Identification and Utilization of Mars resources for construction, manufacturing, agriculture, and atmosphere/life support is a primary mission critical objective.

~ Continuous Pressurized Sub-Surface Mars Equatorial Tunnel System Is Key To Human Settlement Of Mars ~

As resources and capability grows to allow large scale civil engineering, the first critical project will be to dig a continuous sub-surface tunnel system that will completely circle the Mars Equator. This continuous sub surface tunnel system will contain a fully pressurized mass transit system and water/power/communications grid, to allow the efficient connection of the independent equatorial outposts into a continuous and interconnected infrastructure. Using the data from the Chunnel Tunnel Project that now links France and Britain under the British Channel, it is within the realm of doable to construct a continuous sub-surface tunnel around the Mars Equator in 10 to 15 years. Future Mars Settlements and Cities would piggy back on this continuous sub-surface tunnel around the Mars Equator. Once self sustaining outposts have been established on Mars, and if a systematic geometric and grid planning philosophy and strategy is employed and utilized, large populations of settlers and knowledge, resources, tools, machinery, and technology can be shuttled to Mars for the establishment of large settlements and cities along the continuous sub-surface tunnel system around the equator of Mars. Acidic Ideologies & Politics MUST be avoided!

~ Human Nature & Global Realities Are The Main Threat To Human Space Exploration & Mars Settlement ~

If human nature, political correctness, and acidic ideologies are allowed to set the standards for settlers that will be selected to settle Mars, all hope for Mars Settlement will collapse, and this chance for humanity to have a new fresh start will be destroyed, likely along with Human Civilization on Earth. It's very important that those humans selected for this endeavor be of the highest physical, mental, and aspects of character, regardless of which nations or peoples of Earth they originate from. The mere fact of the extremely high level of scientific & technological needs and demands required of the settlers on Mars, and the extremely rugged and dangerous nature of the environment and reality that settlers on Mars will face. If the demented and sociopathic ideologies presently abounding everywhere on Earth are interjected into this new Human Frontier and the Human effort to settle Mars, it is absolutely assured that a massive disaster will transpire. The picking and training of International Space Agency (ISA) Personnel and the selection process of any potential Mars settlers MUST be done in the strictest secrecy outside the public domain for this reason, and conducted by the strictest TQM standards and protocols. It is sad that this very hopeful opportunity for humanity must be dealt with and addressed in this manner, BUT if it is NOT, it is absolutely guaranteed that every human malcontent and degenerate on Planet Earth will show up at International Space Agency (ISA) training and operations centers, throwing human feces and spewing ignorant rants at ISA Personnel and International Scientists working on Mars Exploration and Settlement efforts. If any person reading this, that has NOT the wisdom and integrity of mind to acknowledge this FACT of the dark side of Human Nature, they are not only in full denial, but will surely become the leaders of the human malcontents and degenerates who will storm the gates of the ISA while hurling human feces and spewing ignorant rants. Every major government on the face of the Earth, REGARDLESS of political/religious/cultural ideologies, has secret plans to deal with the masses if a major disastrous

event man made or natural catastrophically collapses civilized society, because THEY KNOW the dark side of human nature. And these SECRET PROTOCOLS are NOT to deal with potential enemy nations or adversaries, but to deal with their OWN PEOPLE! As the Space Frontier Opens and Mars Settlement becomes reality, those member nations of the ISA must secretly and seriously address this very real and daunting issue. Also, in this same vein, the potential reality of a planetary disaster scenario, where a Noah's Ark last resort program to move human populations to Mars must also be secretly addressed. I am sure the Dinosaurs wished they had an International Space Agency and an escape plan, when that asteroid hit the Earth! Such serious, scary, and very real topics as this, MUST be addressed secretly, for obvious reasons, but must indeed be addressed, none the less!

~ Humanity Is Now At A Critical Pivotal Point In which Its Very Existence Is Now At Stake ~

The Ancient Egyptian Pyramids where not Tombs, they where Archives, Libraries, and Maps of Heaven on Earth. They are also remnants and symbols of a Once Great Ancient Civilization. These marvels of human endeavor where likely built by slaves, tradesmen, engineers, and some of the greatest thinkers, doers, and builders of their time. They where built specifically to last the ages, and where indeed maps of the Stars in the Heavens on Earth, **Literally**; as we now know today that the great pyramids where a physical map of the Sirius Star System on Earth. Human Organizations, like the Pyramids, if built on the Limestone Foundations of Vision, Truth, Wisdom, and Knowledge will indeed last the ages. What will those 4000 years in the future remember of the great Nations and Peoples of Earth in 2019 AD? Hmm! The Ancient Egyptians built the Heavens On Earth; the International Space Agency will take Earth to the Heavens. We are Not Alone in this Infinite Universe, as; **"It Is On The Earth, As It Is In The Heavens!"** ALL the Human Horrors and Wonders of Earth, are Not a Single Grain of Sand in ALL the Deserts and Oceans of Earth, compared to the infinite expanses of creation, the Universe! If We, Humanity, do not go to the Stars First!, indeed, the Stars may come First to US! When this day comes, and it will, **if it has not already occurred?** Humanity of Earth may NOT be the smartest or strongest! Any house, even one as large as Planet Earth, lives or dies by the age old wisdom, in which: **"A House Divided Will FALL, and, A House United Will PREVAIL!"**. Indeed, this is the wisdom of the ages, which has been manifested and repeated again and again through out human history on Earth, both for intentions of evil, and for good..

The Nation State is a modern extension and evolution of the City States, and the City States owe their existence and prominence to the Kingdoms and Tribes of the ancient *"Peoples"* of Earth. One day Earth will attain status as a Planetary State, but this will NOT be possible for many generations into Future Human History and affairs, due to the fundamental and engrained flaws in Human Nature. However, due to the fact that the Secrets of Knowledge, Science, and Technology have escaped the confines of the Priesthood of Pandora's Box, and the Apple of Knowledge has now been consumed by Adam & Eve, we citizens of Earth are today faced with terrible weapons of mass destruction under the Whims, Desires, and Lusts of Human Nature and Raw Corruptible Power Unleashed. If the Kings and Tribal Leaders of Earth are not given a way to save face, and the means and foundations to peacefully coexist and survive, and to redirect this awesome Knowledge, Science, and Technology and Human Energy outward into peaceful and productive endeavors, with benefits for all the Inhabitants of Earth, the end result sadly, and predictively, will only lead to utter destruction, mayhem, and horrors of unimaginable magnitude. It is unlikely that humanity and civilization as we know it today in 2019, will survive this, and indeed it is unlikely that most living things on Earth would survive.

Many wisemen and teachers of Earths past and present cultures, societies, and empires have already since ancient times prophesized this very thing, ALREADY. We can not change the past, no more than to cry over spilled milk. The present is a dilemma, because the old minds and past realities of Earth and its Human History, are locked into perpetual conflict over control and dominance dictated by Human Nature, and thus is incredibly hard to gain any real change or progress. However, the future is a blank slate on which the powers at be in the present, can contemplate and learn from the past, and then postulate and prepare for the new possibilities of the Future. Thus, it is only in the future where any real change can, or must, be planned and preparations made for; and it is the new minds of a new Heaven and Earth that will achieve this ends. WW1 and WW2 began to display the utter mayhem, destruction, and horrors of scientific and technologic based human warfar, in which in one single battle, more destruction and death occurred than ALL the ancient battles COMBINED up to that date. Humanity will not survive WW3.

Another key and major stumbling block of human nature, and affairs on Earth, is that some human beings have already evolved and advanced to sophisticated societies capable of producing extremely advanced machines like the American Space Shuttle, and Nuclear Weapons, while others only an arm distance away still cloth themselves in animal skins and forage and hunt daily to survive, and engage even today in tribal cannibalism, head hunting, and extremely dangerous tribal customs and behaviors unsuitable and acidic to any refined advanced and peaceful human society. A member of a highly advanced refined society is no more prepared or able to enter an undeveloped tribal hunter gather society, then would be a member of a hunter gather society be prepared or able to enter an advanced refined society. There are very real dangers in migrations in both directions, but the most dangerous destructive migration flow, is when hunter

gather societies migrate into advanced refined societies, as when backwards and undeveloped tribal customs and nature obtains the infrastructure and advanced knowledge, science, and technology “Nuclear Tipped Spears” of advanced refined societies, it is akin to giving a small child a box of matches in a room full of gasoline. A small child is NOT mature or experienced enough to have a box of matches, let alone an ignorant, demented, or psychotic human adult. Human History is FULL of stories of Refined Advanced Societies coming into collision with Tribal Hunter Gather Societies, and as far as I am aware, most of these refined advanced societies did not survive it, and are gone today.

A Space Faring Society, offers a solution to this collision of Societies and Cultures, as it allows the refined and advanced societies a natural path to continue to advance in relative safety and seclusion from hostile and war like tribal human societies and cultures with limited transfer of knowledge and science which would have harmful repercussions for all concerned, while at the same time leaving the many tribal hunter and gather societies alone and undisturbed to mature and evolve naturally, with out interference. Those that can or want to evolve and advance, will, but mark my word, on the future day a crew on a Star Ship from Earth visits another Planet in another Star System, there will still be humans on Earth hacking each other to death with swords, and humans in tribal enclaves naked or clothed in animal skins hunting and gathering off the land and forests of Earth. There is now over 12,000 years of agreed on main stream human history and archeology, and 80,000 to 100,000 years of controversial and fragmented human history and archeology on Earth, and today many humans live and are bound by tribal customs and nature which have not evolved or advanced much in that long span of human history, and it is unlikely that the fundamental realities of human nature, culture, and potential will, or even can, change much in the next 12,000 years. When the refined advanced society is backed into a corner by the hostile tribal society, and faces annihilation at the tip of a spear, the last action before the on set of death, will be a single press of a button, and in a flash of intense white light, all will be annihilated. There are those who are very controversial and not recognized by main stream academia, that say this scenario has already happened in the ancient and forgotten history and consciousness of Earth, in many repeating cycles, and some philosophers and religious persons are warning us it is about to happen again. Those who fail to learn from the failures and disasters of human history, are doomed to repeat it.

However, small bands of human societies and advanced refined culture, may resist human urges and nature of the primal tribal past and culture of Earth, to escape and expand into the Space Frontier to evolve and create a new Space Faring Society of peaceful, consciously, and spiritually refined beings, that will use advanced knowledge, science, and technology for peaceful, constructive, and collectively beneficial enterprises and human endeavors. This next stage of human development will not, and can not, happen on Earth, it will and can only happen as those rare and gifted humans who will represent the cream of the crop of men and women from the four corners of Earth, who will carry human awareness and consciousness beyond the confines of Planet Earth. As human society of Earth expands outward on the Space Frontier, we will very likely meet others like us, conscious beings, among the vast infinite Frontiers of Space. Some will be xenophobic and reclusive, others benign or peaceful, and yet others will not be peaceful and could likely pose a mortal danger to any being or creature unlucky enough to fall into their path or awareness. Even if they are friendly or benign, what if they are innocently and unwittingly carrying some virus or pathogen that Humans or Life on Earth have no natural resistance to, the implications of such an encounter would cause a pandemic of UnEarthly Proportions and would be horrific and catastrophic? As we venture into the Frontiers of Space, indeed, some of the most dangerous enemies we may yet encounter will be microscopic viruses and pathogens lurking underneath some rock or crevice somewhere, or some natural danger we are not yet even aware of, or know about, let alone even remotely understand. I doubt the Dinosaurs and 80% to 90% of all life and creatures on the Earth had even the remotest sense or understanding of what was about to happen to them, as the massive “*Asteroid/Comet*” headed for its fateful and eventual impact with the Earth off the eastern shore of Mexico. This impact was so powerful, that massive earthquakes and volcanic eruptions caused by the impact waves trough the outer crust and tectonic plates of the Earth, where everywhere on the face of the Earth, ocean tidal waves hundreds of feet high circled the Earth faster than a supersonic jet, and the atmosphere of Earth was superheated causing forests and foliage around the Whole Planet to burst into infernos that covered hole continents. All of this happened with in only mere hours after the massive impact. That massive impact crater can still be seen today by Satellites in Earths Orbit. There have been several modern events in the last 300 years of similar events on smaller scales, but still on the scale that a modern city like New York City would have been totally destroyed had any of these recorded events happened over the city. The intimate danger we humans pose to ourselves, the extreme realities of natural events that could have planetary implications, and that the vast infinite creation of the Universe, holds vast yet unknown possibilities and dangers we are not even yet aware of, or even know about. Indeed, it is unrealistic to think that among the vast infinite frontiers of space that Humans of Earth are the only conscious living beings in the universe, and this reality could have some very serious implications as well. Humanity must explore and advance into space, if it is to survive the ages. We must be prepared for what is OUT THERE, lest we encounter it, or it COMES HERE!

The ISA is a PEACEFUL and PRODUCTIVE TOOL and BRIDGE between the OLD and NEW Worlds, and Minds, of Earth. One day in the Future, maybe in few Hundred Years if Humanity does not destroy itself, or is destroyed,

Earth may be ready for a Planetary State and a World “Earth” Space Agency “*ie: Like The Science Fiction Star Trek Federation*”. However, the present realities of Human Nature and the Nation State does NOT present the fertile ground for any such reality to transpire or materialize, in Our Time, and in fact; those secret forces TODAY pushing for a NEW WORLD ORDER, if successful, will create the most Ruthless and Evil Human Institution to ever see the light of day on Earth; and will INDEED, because of their evil nature and lust for power, wealth, and control, will very likely destroy themselves, along with nearly every other living thing on Earth.

The true success of Earths Future, will fall on to the shoulders of the brightest and strongest young men and women from the four corners of Earth, who will come to the International Space Academy of the International Space Agency, and train and learn together in a peaceful unified core culture, and will then venture outward from their common home, Earth, to distant points to live, learn, grow, and die together as citizens of Earth. It is these new minds and spirits that will look out the port holes of their bases, stations, and ships and see in the distance one pale blue dot, Earth, from which they ALL owe their heritage and existence to. It is ONLY THEN, when this fertile ground of Human Awareness and Realization, is achieved, and when these voyagers of mind, body, and spirit who once came from the four corners of Earth, return HOME to THEIR EARTH; will the New Heaven and the New Earth become a reality in the Collective Consciousness of the Human Inhabitants of Earth.

I will never likely live to see this day, nor will you, but every long journey begins with a single step. Our true success and contributions in this existence, in this realm, in our time, is not what we can take with us past our brief lifespan, but what we leave behind for future generations. I have sacrificed much to see that this endeavor, enterprise, and gift to future generations of Earth is successful and manifested from vision into action, from action into existence, and from existence into a legacy that will last the ages. One day a crew from Earth will visit another Star System, they will owe that day, to what we do today. In fact, the very continued existence and survival of Humanity, and Human Civilization as we know it today, will most surely be the result of the actions and deeds of this very generation TODAY. As we near the year 2020 on the Roman Calendar, the very narrow window of opportunity for Humanity to be able to become a full and established Space Faring Civilization, is indeed, the very event that will either doom Humanity to turn in on itself in an Armageddon of self inflicted destruction over a Finite Earth, or propel Humanity into a Peaceful and Hopeful future into the Infinite Domains of the Space Frontier now with in our grasp. **Chose well.....!**

DREAMS

A Dream Is The Stepping Stone To Goals
Goals Are The Pathway To Determination
Determination Opens The Door To Success
Success Leads To A Better Tomorrow
Tomorrow Is No More Than A Dream Away
A Dream Is To Discover The Undiscovered
A Dream Is To Climb The Highest Mountain
A Dream Is To Cross The Vast Oceans
A Dream Is To Soar Like The Birds

A Dream Is To Walk On The Moon
A Dream Is To Reach For The Stars
A Dream Is Today's Tomorrow
Tomorrow Is Only A Dream Away

Poem By, “Richard” Rick “Lymon” Redigo “White” Dobson, Jr. “Gallagher”
Copyright November 1982 – All Rights Are Reserved

This poem was written by Admiral, Rick R. Dobson, Jr. in his Senior Year of High School, in November of 1982, in Horseheads, New York State, in the United States of America, and later that year he entered service in United States Naval Aviation, and served 15+ years honorably in Military Aviation, and later entered college in a Bachelors of Science Degree in Aeronautics & Applied Mathematics with a minor in Philosophy, and in 1986 started his life long work with the International Space Agency. The International Space Agency was Incorporated in 1990 as a Non-Profit Scientific & Aerospace – Research & Development & Consulting Corporation, and today is seeking International Treaty & Charter Status. Admiral Dobson is a simple man who dared to Dream Big, and sadly like many other visionaries and dreamers in history, has suffered and sacrificed greatly! Having a proud Irish family lineage, on the other side of this poem is presented a Historic Poem by Irish Poet Sean O’Casey, as well as an important and hopeful quote from history.

APOTHEOSIS

The Irish People “Of Earth”

We Are All Irish
And Carry Our Spirit
And Our Characteristics
With Us Where Ever We May Go
God And Nature Has Given Our World
A Colorful, Delightful Variety Of Peoples

**But There Is Only One Race
The Human Race
We Are All One
Flesh Of Each Others Flesh
And Bone Of Each Others Bone**

Poem By Irish Poet, Sean O'Casey

Recited For Historical Reference Only - With No Intention Of Ownership or Profit

Message From The International Space Agency

Almost 5 decades ago now, during a historic speech at the United Nations, the late President of United States of America, John F. Kennedy, proposed that our quest to the moon be an International Endeavor. The politics of the time did not allow for the fulfillment of that Dream. However, Adlai Stevenson, President Kennedy's Ambassador to the United Nations left us today in 2019 this message of Hope. *"Perhaps Our Children Will Sail Together To Mars"*

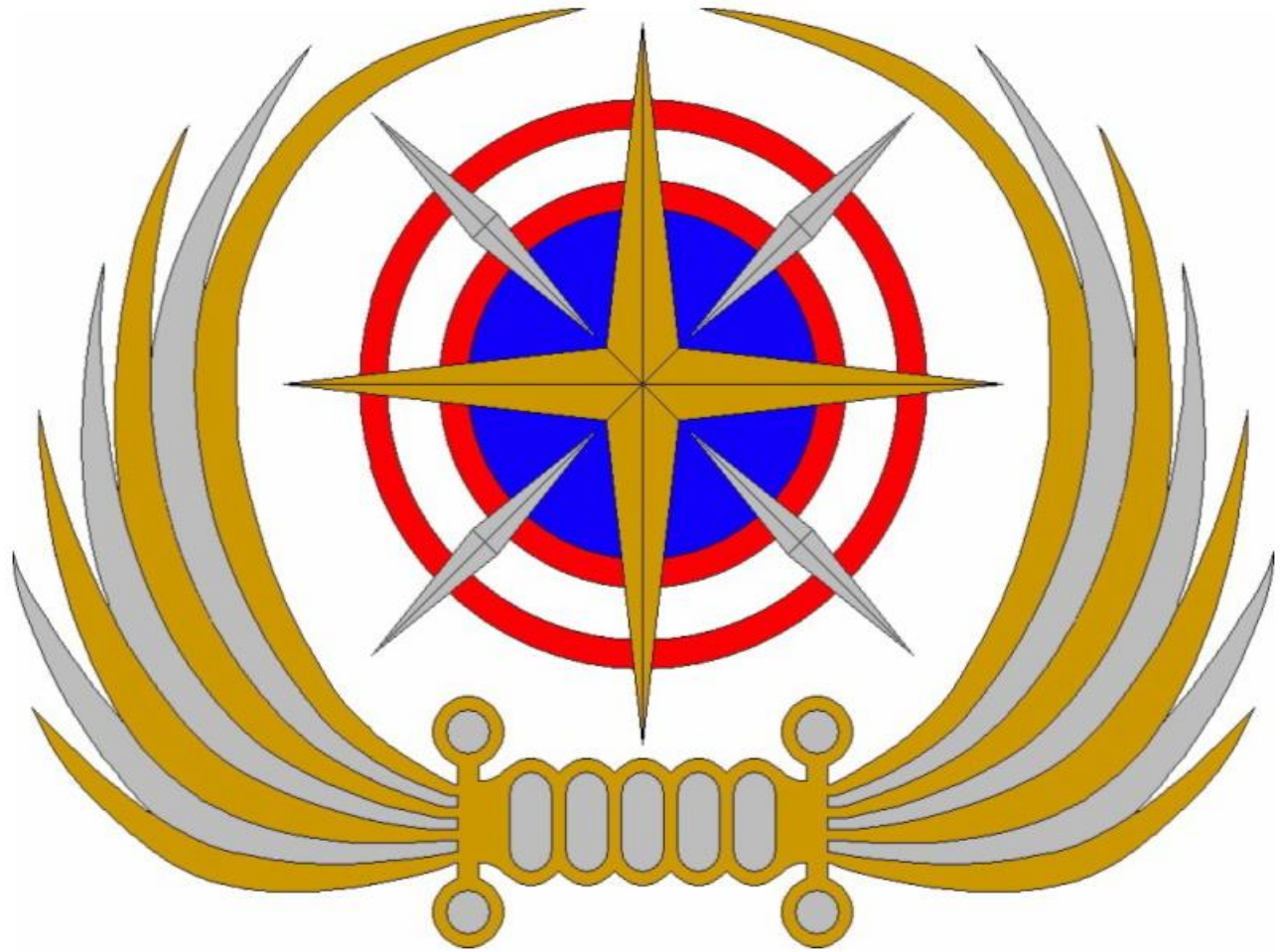

International Space Agency, ISA

International Space Administration

Founded In 1986 -&- Incorporated In 1990

Scientific and Aerospace - Research & Development and Consulting

New York State - Not For Profit Corporation - United Space Federation

Presently Seeking International Treaty & Charter Status

**Private Diplomatic and Proprietary
Planned Meetings in Washington, D.C.
Proposed for June / July of 2019**

U.S.A. Registered ® : Trademark ™, Copyrights © : 1986-2019 All Rights Are Reserved



INTERNATIONAL SPACE AGENCY – I. S. A. INTERNATIONAL SPACE ADMINISTRATION AD-ASTRA – TO THE STARS – IN PEACE FOR ALL MANKIND

Founded In 1986 - Incorporated In 1990 - Presently Seeking International Treaty And Charter Status
United Space Federation / Scientific & Aerospace - Research & Development / Non-Profit Corporation / New York State / U.S.A.

MAILING ADDRESS: Post Office Box 541053 , Omaha , Nebraska , 68154 , United States of America
Omaha, Nebraska, Administrative Offices: (402) 299-2799 Washington, D.C., Diplomatic Offices: (202) 917-0209
Denver, Colorado, Advanced Space Propulsion & Technology – Research & Development Center: (303) 201-0148

NOTICE: Letter Is Diplomatic & Proprietary , Non-Profit Public Release Authorized , All Use With Respect For Trademark & Copyrights : NOTICE

DATE: 28 February 2019	SOLAR DAY: 59	TIME: 11:31 PM	Type: External	CLASS: CAP	CAT: INT	PAGE: 1 of 11
SUBJECT: International Space Agency -Diplomatic & Proprietary & Private Meetings – Washington, D.C. June/July of 2019						
COVER PAGE: To The Global Space Community						

BCC: ARN: SD:59-YR:2019-MT:02-DY:28-SB:DCMeetings -AU:Dobson-PG:17-CL:CAP-TY:External-CA:INT-RN:7772019

DATE: 28th of February, 2019 – SOL 59

TO: The Global Space Community;

Government Embassies in Washington, D.C., in the United States of America, and Globally,
National Space Agency Offices in Washington, D.C., in the United States of America, and Globally,
Non-Government, Corporate, Scientific, Academic, and Private Space Organizations, Institutions, Individuals, Globally,

ATTN: Ambassadors & Attachés - National Embassies;

Directors & Attachés - National Space Agencies;

Leaders & CEO's - Aerospace, Scientific, and Academic - Communities, Corporations, Institutions, and Organizations;

Dear, Esteemed Ladies and Gentlemen, Respectfully,

We at the International Space Agency ask for just one moment of your busy time, for a Noble and Historic Endeavor of Great Magnitude to the Benefit and Well Being of the Future Affairs of the Peoples of Earth, Thank You. Please know we are asking for this Diplomatic and Proprietary Dispatch and Communication to be widely redistributed and retransmitted among the Diplomatic and Aerospace Community, to insure it is received and known by those in positions of power and influence. We are also asking that those receiving this communication, who support its objectives and purpose, to present it on their organizations websites, so it can have expanded awareness in target Diplomatic, Aerospace, Scientific, and Academic Communities, Globally. We are also asking the Diplomatic and International Communities, to translate this historic Diplomatic Communication from the International Space Agency, into the many Languages of the International Community, and Peoples of Earth, so its message can find wide understanding in the Consciousness of the Peoples of Earth, Thank You.

Since its Founding in 1986, the International Space Agency Organization has had to struggle against established thinking, ingrained power blocks based on rivalry and political objectives, and basic misunderstandings mostly from the fact that people and organizations globally did not properly understand what the International Space Agency was or what it offered over the established way of doing things.

This has lead to intense passions, entrenched protectionism, unfortunate misunderstandings, and even clashes of words and deeds, which have been less than positive for all concerned, or has this advanced in anyway the peaceful and productive advancement of the Human Space Exploration Endeavor in the last 32 years. We plead, and beseech, that those of you receiving this Confidential & Proprietary Diplomatic Dispatch, and who are Key Leaders of the Space Community and Human Space Endeavor, to accept our humble offer to come to the round table of debate and negotiation regarding the International Space Agency and its Historic Vision and Important Endeavors, in June/July of 2019 in Washington, D.C.. This date is a proposed time frame, and may change as support for these meetings developes, and the list of potential representatives and attendees grows and becomes more defined. Pledged support for these meetings, is greatly needed, and is humbly requested.

The International Space Agency has grown over the years, since it was Founded in 1986 and formally incorporation in 1990, lead by a very small but very determined group of visionaries and dreamers. Yes, the International Space Agency is at present a very small and insignificant organization with limited resources, support, and understanding when compared to the standards of National Space Agencies like NASA, Roscosmos, ESA, CNSA, JAXA, ISRO, Ect.... and Big Global Aerospace companies like SpaceX, Boeing, Ariane Space, Energia, Airbus, Great Wall Of China Industries, Honda, Ect.... Indeed, they where ALL once like International Space Agency is now!

However, all things must have a humble beginning, and every long journey begins with one first step! The Airplane had the Wright Brothers and fragile Wright Flyer. National Aeronautics And Space Administration, NASA had the NACA. European Space Agency, ESA, from a small band of intensely competitive European independent states. And so on, and so on.... Every journey indeed starts with a simple FIRST STEP!, and sometimes that fist step, and its following initial steps are baby steps, and in many cases at a snails pace. Change, new ideas, and new ways of doing things has never in Human history gone smoothly and with out resistance or risk. Galileo Galili was nearly burned at the stake as a heretic for presenting knowledge of our solar system and astronomy that is common knowledge today, Wilbur and Orval Wright where mocked and viciously ridiculed as crazy mad men who wanted to flap their arms and fly like birds and today many millions of human beings fly every day like the birds to the four corners of the Earth; Nicola Tesla the greatest scientific and creative mind of the modern era was viscusly ridiculed as a mad scientist and warlock for his genius and great works and deeds for the benefit of Humanity, and today his genius gives us A/C Power & Radio

International Space Agency, I.S.A.: Name, Public Identity, Logo, Emblem: Are: U.S.A. Registered ®: Trademark™ & Copyrights ©, 1986-2018, All Rights Are Reserved
United Space Federation, U.S.F.: Scientific & Aerospace - Research & Development / Non-Profit Corporation / Incorporated 1990 / New York State / United States of America



**INTERNATIONAL SPACE AGENCY – I. S. A. – INTERNATIONAL SPACE ADMINISTRATION
AD-ASTRA – TO THE STARS – IN PEACE FOR ALL MANKIND**

Founded In 1986 - Incorporated In 1990 - Presently Seeking International Treaty And Charter Status

NOTICE: Letter Is Diplomatic & Proprietary, Non-Profit Public Release Authorized, All Use With Respect For Trademark & Copyrights

DY: 28 February 2019 SD: 59 TM: 11:31 PM TY: External CL: CAP CAT: INT PAGE: 2 of 11

Controlled Devices & Microwave Ovens & Laser Technology and many other modern technology advances and knowledge; Howard Hughes was viciously hounded and mocked for daring to build the worlds largest flying boat “Hercules 500” and amazingly out of wood which was branded out of spite and jealousy the “Spruce Goose” which Howard Hughes INDEED built and actually operationally flight tested; and sits in the Evergreen Aviation & Space Museum in Portland, Oregon, U.S.A. and today is one of the most visited objects on Earth; the all knowing Nay-Sayers said that flying faster than the speed of sound was impossible until a man called John Glenn broke the sound barrier; and people where once called lunatics “crazy” for saying that man could “and would” walk on the moon until a man called Neil Armstrong stepped off the Lunar Lander Eagle and said the now famous words: *(One Small Step For “A” Man And One Giant Leap For Mankind!)*. All of these things where said by the all knowing educated elite and nay-sayers of the time as impossible feats, but yet INDEED, they have been done! A great and visionary man, Admiral, Rick R. Dobson, Jr. who is the Founder of the International Space Agency, in 1986 against incredible odds and adversity, dared to step up to home plate and take a swing at history, and in doing so sacrificed everything and suffered deeply from the whips and lashes that where like wise felt by Galileo Galili, Wright Brothers, Nicola Tesla, Howard Hughes and those who gave us John Glenn & Neil Armstrong. There are well known sayings like “Rome Was Not Built In A Day”, “Every Journey Begins With A Single Step”, and one of the most notable children’s stories and parables about the fictional race between the Hare “rabbit” and Tortoise “Turtle” in which the faster Rabbit does not win the race, but indeed the slower and more determined and humble Turtle crosses the finish line first.

Indeed, the Airplane had the Wright Brothers and the fragile Wright Flyer. NASA had NACA. ESA materialized from a small band of intensely competitive European independent states. Galileo Galili was nearly burned at the stake, because he said the Earth revolved around the Sun; the Wright Brothers where called crazy bird men and endlessly attacked because they dared to say that man could fly through the air like Birds; And so on, and so on.... As an American, I am naive to the likewise traditions and histories of other cultures and nations, on Earth, but I am very wise to the fact, that this dilemma and human nature abounds everywhere. Change is not easy, in any age, in any culture, or any place on Earth. The Vision and Endeavors of the International Space Agency represents CHANGE, and in so, it must fight for every breath it takes and every inch it moves forward. There will come the day, when the minds and consciousness of the many peoples of Earth will take the reality of the International Space Agency for granted. It is YOU who now read this historic dispatch and plea for help, that will either bring this vision to LIFE through your actions and deeds, or set in motion the sharp fiery arrows that will DESTROY it! The Future of the International Space Agency is NOW in YOUR HANDS, literally! So, Ponder well this decision of great importance, that will have great impact on the future course of human events and history! What will those 100 to 200 years in the future think of us today, we humans who had the future in our hands?

With the specter of nuclear missile subs of Russia, Europe, China, America roaming our planets oceans, EACH ONE having the destructive power to completely obliterate whole continents, killing every plant, animal, and yes, human, on that continent! Nations also possessing the ability and means of biological weapons, that mere ounces of a weaponized virus or biological agent can wipe out whole cities in a most horrific and frightening way. Even now on the frontiers of science and technology, weaponized applications of supercomputer technology could create self aware computers that have no morals or remorse, and could become a Frankenstein monster turned loose on its creators with cold calculating precision and unlimited potential. Research into X-Ray Weapons and Energy & Frequency Weapons that not only kill and destroy UNSEEN, but indeed fragment and self destruct the Human DNA genetic strands, as well to plant and animal DNA, leaving living things as walking dead, and either preventing procreation, or yielding great pain and suffering that has generational implications. Even the purposeful tampering with Human DNA to create super Humans and Super-Soldiers, including mingling animal DNA with Human DNA to create Human Hybrids that for example could have enhanced night vision, or hearing, or smell, or greater speed and strength. Even in the arena of the human mind and consciousness are attempts to merge technology to biology, and to manipulate human mind and consciousness for either nefarious purposes or military use. In all of the above references to militarized or nefarious uses of science and technology, it must be noted that such things if under civil or positive control for the benefit of Humanity, would greatly enhance the well being of Humanity. Just a few examples of which would be, Nuclear Fission & Fusion for Civil & Space Power & Propulsion, Civil Biological Research to find cures for Disease, Use of X-Ray and Frequency Technology for Civil Medical & Manufacturing purposes, Civil Genetic research for legitimate peaceful & medical purposes, Civil human mind and consciousness studies for legitimate peaceful & medical purposes, and the peaceful & legitimate civil use of computers and robotics to benefit and serve humanity, NOT to harm, dominate, or control Humanity!

With Humanity now possessing the means and ability to its own destruction, and indeed most of life on Earth along with us! Is it therefore not much to ask, for such a peaceful and hopeful potential out let, and use, for Science and Technology, as the International Space Agency, which potentially could open a vast and infinite frontier of great opportunity and HOPE for Humanities Future Well Being And Survival, to be given a fair and honest chance to prove its worth and potential?! How can the powers at be, loose face, or look weak by coming to the International Space Agency negotiating table in Washington, D.C. in June or July of 2019?! Hmmm! I dare say the WE at the International Space Agency HAVE something you NEED! An EXCUSE to sit at the same table with your enemies, allies, protagonists, and supporters for something that may offer a way to push the Nuclear Clock back from Midnight by a few minutes! Surely NO HARM could come of it?, indeed the likely hood is, that rather MUCH GOOD could, and WOULD, come of it! Please!, Come, put your awesome and frightful weapons of mass destruction in your back pocket, and just temporally retract your claws, and give you, me, them, and all of humanity and life on Earth a CHANCE to survive this rolling snowball of madness. We of Earth are turning IN on Ourselves over a Finite Earth that in the end will only lead to ONE SURE Conclusion; when Humanity is NOW on the thresh hold of an INFINITE frontier, which will allow humanity to turn OUTWARDS peacefully into a potential of unlimited resources and opportunities, beyond all imagination! Come to the Round Table, and give our children, and their children, a chance at a future for the Peoples of Earth! And if not for me, or them, do it for YOU and your Childrens CHILDREN, and indeed all life on Planet Earth.

**International Space Agency, I.S.A.: Name, Public Identity, Logo, Emblem: Are: U.S.A. Registered ®: Trademark™ & Copyrights ©, 1986-2018, All Rights Are Reserved
United Space Federation, U.S.F.: Scientific & Aerospace - Research & Development / Non-Profit Corporation / Incorporated 1990 / New York State / United States of America**



INTERNATIONAL SPACE AGENCY – I. S. A. – INTERNATIONAL SPACE ADMINISTRATION
AD-ASTRA – TO THE STARS – IN PEACE FOR ALL MANKIND

Founded In 1986 - Incorporated In 1990 - Presently Seeking International Treaty And Charter Status

NOTICE: Letter Is Diplomatic & Proprietary, Non-Profit Public Release Authorized, All Use With Respect For Trademark & Copyrights

DY: 28 February 2019 SD: 59 TM: 11:31 PM TY: External CL: CAP CAT: INT PAGE: 3 of 11

Has the International Space Agency made mistakes over the years? Sadly, Yes, and mostly from inexperience and lack of proper resources and support. However, ISA has grown, learned, and matured over these last 32+ years, as also has its vision and endeavors, that will one day soon have better resources and support. We at ISA at least deserve to be recognized for our determination, zeal, and many sacrifices in patiently enduring the gauntlet for 32+ years. In the End, it will not be Admiral Dobson that will benefit from the eventual success of one of the most important and historic efforts and endeavors of our time. It will indeed be a Legacy to Benefit all Mankind! *Rome Was Not Built In A Day - & Every Long Journey Begins With One Single Step - & The Parable Of The Tortoise and the Rabbit, Hmmm...!* SO, What HARM will it be, for the negotiation round table of wisdom to be filled with those seeking answers to their questions, and indeed hollowed ground on which key and important persons can actually contribute their input, ideas, concerns, and hopes?!

So the International Space Agency is humbly asking you Ladies and Gentlemen of Esteem and Prominence to come to the Round Table in June/July of 2019 in Washington, D.C., and **BE A PART OF HISTORY IN THE MAKING!** For the International Space Agency is indeed, YOU! It is the SEED of a GREAT OAK TREE, and it is YOU whom is the EARTH and WATER which will give it life, and GROW IT from a SMALL SEED OF VISION into a massive and beautiful TREE of an Organization that will greatly BENEFIT Humanity of EARTH as it enters the Infinite Frontiers of Space. Future Humans that may one day travel to distant stars and destinations, will owe their destinies and existence to what WE do TODAY! **Ad-Astra! To The Stars! In Peace For All Mankind!**

The American President, and NASA, have dedicated the American People to a dream to reach for the Stars! The Russian President, and Roscosmos, have formally stated that International Cooperation is needed on the Space Frontier and have backed this with resolve and dedication. The European Community, and ESA, have likewise formally acknowledged that cooperation is not only needed, but is necessary if any real success is to be achieved. The Chinese President, and CNSA, have with great effort and resolve, entered the space arena in meaningful and major ways, and becoming only the third Nation in history to achieve human orbital space missions, and furthermore making it also known that they would welcome international cooperation. Other smaller and emerging Space Nations like India "ISRO" and Japan "JAXA", have in a massive flurry over the last few years negotiated and positioned themselves to take advantage of the opening of the next Great Human Frontier, the Space Frontier. Which they all know is very near to being fully opened to human efforts and enterprise, and will represent many Trillions of Dollars in New Jobs, New Technologies, and many New Economic Opportunities. In over 500+ meetings organized or sponsored to date by the International Space Agency since its first historic International Space Agency Meeting on May 22nd of 1992 at the Carnegie Endowment For International Peace in Washington, D.C., USA, it has been stated over and over and over again by the Government, Aerospace, Scientific, and Academic attendees at these many meetings, that international cooperation in the Human Space Endeavor was not only sought and supported, but was, and is, required due to the cost, complexity, scope and scale of such endeavors. So to be blunt and direct, is it not now time for every one to stop dancing around, and to now start putting their signatures onto the International Space Agency Treaty effort. Hmmm?!

This paragraph was hard for me to write, as it deals with the ugly reality of human nature, and is less than positive, but sadly, it MUST BE ADDRESSED! If greedy and self centered humans or organizations get their teeth and claws into the International Space Agency vision and endeavor, it will surely back fire and disintegrate. The International Space Agency has indeed been on the diner menu of such malcontents and egomaniacs since it was founded in 1986! We at the International Space Agency are routinely picking their teeth and claws out of our hind quarters. It is now 32 years, and we are still on our feet, and moving ahead at best possible speed. These planned Diplomatic meetings in June/July of 2019 in Washington, D.C., will not only cast a light onto the parasites and predators snapping at the heels and rear quarters of the International Space Agency, but will bring benefactors, advocates, champions, protectors, and allies into the International Space Agency fold and vision, that have much bigger teeth and sharper claws than the jealous, spiteful, and petty parasites and scavengers now stalking and trying to devour and destroy the International Space Agency. I have been told many times over these last 32+ years **"NOT TO TELL THE TRUTH"** because it is not endearing to the NAKED KING "QUEEN"! But, if the KING "QUEEN" IS NAKED, he "she" is indeed NAKED! I would surely hope when I am old and senile and walk around with no clothes on, that SOMEONE would actually out of compassion and empathy, politely tell me I had NO CLOTHES ON! Hmmm!? They say that TRUTH is a rare commodity now days, and even others say that TRUTH in these perilous and polarized days is a dangerous thing! I will close on this note by simply saying, if the KING "QUEEN" who everyone is afraid to tell the TRUTH to because He the King, "She the Queen" is frolicking through the Tulips NAKED for all to see, and OH BY THE WAY!, also just so happens to have His "Her" finger on the NUCLEAR BUTTON, then I dare say, we are all in for a real rude awakening one day! It would then seem apparent to me that it is not the Tulips we would be embracing, but more like Lilies! But Alas, I must take that back because the Lilies, and the "Apple Trees", and the "Birds and the Bees", and the "Lions and Tigers and Bears, Oh No!", will all be gone as well! Then the Morlocks and Coachroaches will then gallantly RULE THE EARTH! I dare say, that is a very bleak and disheartening thought, indeed! Hmmm?!, **I wonder if the Dinosaurs had even the most remote inkling as to what was in their future, or more correctly, the lack there of?!**

The International Space Agency is proposing for June & July of 2019, planned private and confidential diplomatic and proprietary meetings "that will not be accessed by the media or general public", to propose, develop, complete, and hopefully ratify/approve the International Space Agency Treaty and Charter "Constitution Document". In support of this ends, the following proposed agenda supported by the Global Space Community, in tandem with the proposed opening of the International Space Agency Offices in Washington, D.C. in January/February of 2020.

With this great opportunity and spirit of good will Globally, we at the International Space Agency, plead, and propose the following agenda supported by the Global Space Community, in tandem with the proposed and planned opening of the International Space Agency (ISA) Offices in Washington, D.C. in 2020. We are presently working hard to secure \$4,260,416 Grant, Contribution, or Donation in support of the opening of the International Space Agency Washington, D.C. Office, and Planned Efforts & Projects for 2020 and beyond. Any help or support in this regards, would be greatly welcomed. The "Proposed" ISA Annual Office Budget is provided with this confidential and proprietary diplomatic dispatch.

International Space Agency, I.S.A.: Name, Public Identity, Logo, Emblem: Are: U.S.A. Registered ®: Trademark™ & Copyrights ©, 1986-2018, All Rights Are Reserved
United Space Federation, U.S.F.: Scientific & Aerospace - Research & Development / Non-Profit Corporation / Incorporated 1990 / New York State / United States of America



**INTERNATIONAL SPACE AGENCY – I. S. A. – INTERNATIONAL SPACE ADMINISTRATION
AD-ASTRA – TO THE STARS – IN PEACE FOR ALL MANKIND**

Founded In 1986 - Incorporated In 1990 - Presently Seeking International Treaty And Charter Status

NOTICE: Letter Is Diplomatic & Proprietary, Non-Profit Public Release Authorized, All Use With Respect For Trademark & Copyrights

DY: 28 February 2019 SD: 59 TM: 11:31 PM TY: External CL: CAP CAT: INT PAGE: 4 of 11

The strategy for the proposed and planned ISA Diplomatic & Proprietary meetings in June/July of 2019, is to secure the funds for the staffing and assets required to host and conduct these meetings, through a meeting attendance fee structure, with some additional funds raised through advertising in the primary meeting manual and session reports that will be generated for this historic endeavor and event. The details of this and the proposed and outlined schedule and parliamentary structure of meeting closed door sessions and open sessions is also included in this letter.

As the Global Space Community, both Government, and Civil Sector responds to this most important letter and event, the scope, scale, and full tempo of these planned meetings will materialize and come into focus. If those with Eyes to See, Ears to Hear, and Voices to Empower, carries this communication through out the Global Space Community, amazing things could come from this. As the Founder of the International Space Agency Organization an endeavor, I have given in the last 32 years of my life, all I have, and all I am, at the cost of great pain and suffering and sacrifice, and not to mention the victim of malicious and vicious lies, propaganda, purposeful disinformation, humiliation, loss, and even on a number of occasion's physical harm to myself. I have faced the gauntlet not for fame, fortune, power, title, but for all of YOU! Yes, you! And indeed, all my fellow human beings on this Earth. Here are the formal requests being submitted.

1) This Spirit of Good Will and Cooperation be Formally Embodied in a Draft International Space Agency Charter, which will be signed by all interested Space Nations and Space Organizations Globally, and will act as a starting point to develop more formal Treaty "Constitution" & Legal Agreements By, and Between, International Space Agency Member States & Organizations. This Historic & Important Document will bring the International Space Agency to its next logical stage of development, and will formally acknowledge the International Space Agency as such. Furthermore, it will then allow for real work to begin on an International Fully Reusable Space Plane Launch System and Operational Research and Development to actualize an International Luna Base & International Missions to Mars, as well as a host of other exciting ventures.

2) Each new International Space Agency (ISA) Member State or Organization will dedicate a formal liaison to their Head of State or Chief Executive Officer which will act as the official representative of that Member State or Organization To, and On The Behalf Of, the International Space Agency (ISA) Organization. This will eliminate red tape and unnecessary bureaucratic entanglements and posturing, and allow more rapid and focused development of the ISA Organization and its planned and proposed Programs, Projects, Missions, and Efforts. In effect this appointed person will on the Government side act as the appointed National Ambassador to the International Space Agency Organization, and on the Corporate and Private side act as the Official Spokes Person or Liaison to the International Space Agency. These appointed Officials would sit on two separate commissions. The Government Officials would serve as part of the Space Regulations Commission (SRC) of the International Space Agency, and the Non-Government/Corporate/Academic/Private Officials would serve as part of the Space Planning Commission (SPC) of the International Space Agency. The SRC and SPC would initially be scheduled to meet collectively (Quarterly) every 3 months to provide insight, support, and direction to the International Space Agency Executive Leadership, Management, and Personnel that would be composed of the International Space Administration, International Space Centers, International Space Commands, and also the key institutions of the International Space Academy, International Space News Organization, and International Space Agency Foundation & Societies.

3) Each new ISA Member State & Organization will dedicate one full time staff person "REPRESENTATIVE", to work at the new ISA Offices in Washington, D.C., under the direction and authority of the International Space Agency Director and Chief Executive Officer, to accomplish ISA Diplomatic, Administrative, and Operational Directives and Efforts. These members of the International Space Agency staff will be paid for and subsidized by the signatory and member states and organizations, and thereby greatly expanding the personnel resources of the International Space Agency with limited overhead, and allowing limited resources to be strategically focused on Operational Research & Development and actual Hardware. This will also allow for a diversity of national perspectives and insight to be infused into the International Space Agency Organizational Culture and Dynamics.

4) Each new International Space Agency Member State and Organization will be respectfully requested to provide and dedicate two College or University students, although not a mandatory request, it is humbly suggested for the purpose providing a balanced representation of the source Nation & Culture, that one Male, and one Female, between the age of 18 and 25, be provided to work at the new ISA Offices in Washington, D.C., under the direction and authority of the ISA Director and Chief Executive Officer, to accomplish ISA Diplomatic, Administrative, and Operational Directives and Efforts. These young College, University, and PhD Students will bring the youthful and hopeful inspiration and hope of their generation of the source Nation and Culture, to the future of the Human Space Endeavor. Indeed, many of these bright young people from the many nations around our Earth will not only contribute to the continuing development and growth of the International Space Agency, but will indeed likely be the future officers and personnel that will be future leaders of the international Space Agency and even many of them may one day soon work on the Space Stations, Space Ships, and Luna and Mars Bases that will materialize and come to be as a result of the International Space Agency. Their youthful innocence, energy, and dreams, will be the life blood of the International Space Agency as it comes of age. It is my HOPE that these young bright people from the four corners of our Earth can come together on this New Space Frontier, and look out the windows of their Space Stations, Ships, and Bases and see the EARTH which they ALL came from, and with their fresh youthful innocence and passion, find peace and hope for the future of Humanity.

5) Lastly, we propose a series of Diplomatic and Executive meetings to occur in some location in Washington, D.C., at some appointed dates and times as to hopefully take place in June and July of 2019. These meetings would be confidential, private, and proprietary and would be attended by all interested Governments, States, and Organizations wishing to Debate, Negotiate, Contribute, and Participate in the Creation of the First Draft of the International Space Agency Charter, and to then become Signatories to that very same First Draft of the ISA Charter. This will be the official gateway and path to more defined and higher level meetings that will result in the drafting of Treaty and Contractual documents and agreements, that will then empower, fund, and support the International Space Agency Organization, and giving it the personnel,

**International Space Agency, I.S.A.: Name, Public Identity, Logo, Emblem: Are: U.S.A. Registered ®: Trademark™ & Copyrights ©, 1986-2018, All Rights Are Reserved
United Space Federation, U.S.F.: Scientific & Aerospace - Research & Development / Non-Profit Corporation / Incorporated 1990 / New York State / United States of America**



**INTERNATIONAL SPACE AGENCY – I. S. A. – INTERNATIONAL SPACE ADMINISTRATION
AD-ASTRA – TO THE STARS – IN PEACE FOR ALL MANKIND**

Founded In 1986 - Incorporated In 1990 - Presently Seeking International Treaty And Charter Status

NOTICE: Letter Is Diplomatic & Proprietary, Non-Profit Public Release Authorized, All Use With Respect For Trademark & Copyrights

DY: 28 February 2019 SD: 59 TM: 11:31 PM TY: External CL: CAP CAT: INT PAGE: 5 of 11

resources, and support required to undertake Peaceful and Non-Military International Cooperative and Collaborative endeavors and programs OUTSIDE the capability or ability of the National Domain, and do so in a manner that will insure sufficient scope, scale, and longevity able to allow for sustainability and secure, dynamic, and robust organizational and program infrastructure.

At Present, the number one and most critically important Program and Endeavor being advanced by the International Space Agency since 1988, is the International Space Plane Program and Electromagnetic Assisted Space Launch System. The Space Plane Component of the Program would be a Single Stage To Orbit, Fully Reusable, Space Plane “Like the U.S. and Russian Space Shuttles”; but unlike the U.S. Space Shuttle, there is no main tank or solid rocket boosters. The Electromagnetic Assisted Launch System “Like An Aircraft Carrier Catapult” imparts basically most of STAGE ONE kinetic energy to the Space Plane at launch, and the onboard fuel tanks and engines carries the space plane the rest of the way to stable Earth orbit. The U.S. Space Shuttle was able in its 30 year history able to only achieve 2.6 launches per month, where as the International Space Plane Program and Launch System will be capable to achieve 5 to 7 launches PER DAY or annually between 1865 launches per year and 2555 launches per year. So in 5 days the International Space Plane Program will yield more launches than the entire U.S. Space Shuttle Fleet attained in one year. And an important fact here, is that every time the U.S. Space Shuttle Launched they THREW AWAY a 13 story high main tank of tones of high grade metal ore and millions of man hours and expertise! The International Space Plane Program is 100% reusable, no waste of precious resources and man power. With out the International Space Plane Program and the massive capability it represents, talking about sending millions of tones of materials, assets, and personnel into Earth Orbit and onto Luna, Mars, and Beyond is IMPOSSIBLE! For any enterprise to be managed in a way that every time you put one tone in orbit but throw several tones away to do that is not only unsustainable, but ludicrous! We MUST put the HORSE before the CART! The capability and sustainability of the International Space Plane Program is critically needed to provide TRUE low cost, routine, and sustainable access to Earths Orbit, and beyond, but is OUTSIDE the ability or capability of the Nation State infrastructure or means, and therefore it MUST be achieved as an international collaborative and cooperative frame work like Airbus Industries, and European Space Agency, which is the smaller Regional cousin of the larger Global International Space Agency.

Once the HORSE has been securely hooked up to the CART “Chariot”, then, and ONLY THEN, can we in good conscious talk about an International Orbital Infrastructure of Rotational Gravity Stations, Microgravity Stations like the International Space Station, Orbital Ship Yards and Industrial Manufacturing & Commercial Assets & Fuel Depots, and then onto Luna Bases and Exploration and use of Lunar Orbit for ship yards and large scale manufacturing of space assets and ships, and also Bases on Mars and exploration and settlements on Mars, which will indeed be the NEW WORLD of our age, literally! But until the HORSE is securely in front of the CART all such talk is useless and unsustainable! Bring the International Space Agency Organization into full focus, THEN, empower and fund the International Space Plane Program and International Electromagnetic Assisted Space Launch System, and THEN, as they say, WE ARE OFF TO THE RACES! I assure you, if, and when, a human from Earth sets foot on Mars, it WILL NOT be an American, or Russian, or Chinese, ect, ect, Flag on the Uniforms of the Crew or on the Space Craft, or even the Corporate Icon of Space X, Arienne Space, Energia, Honda, ect. Ect., or the symbol of the iconic National Space Agencies like NASA, Roscosmos, CNSA, ESA, ISRO, JAXA, ect., ext., it will in fact be the emblem of the International Space Agency (ISA), it is just a matter of fact of the reality of economic and material management and sustainability!

It is NOT that the International Space Agency replaced, eliminated, or even controls any of these flags, icons, institutions, governments, and ideologies, but IN FACT embodies them collectively and symbiotically into its very being and existence. The crew will come from MANY Nations, and the support and expertise to carry out such a daunting mission and endeavor will come from MANY National Space Agencies, and every nut, bolt, screw, wire, and component of the space craft that lands on Mars will have been PROUDLY made by companies like Space X, Arienne Space, Energia, Honda, and many many others around our Planet Earth! The International Space Agency like a coral reef looks like a single entity, but in fact like a coral reef that consists of millions of individual entities, like wise the International Space Agency is made up of many individual entities working TOGETHER to achieve a common goal and endeavor which none of them could have ever achieved individually. So even through the EMBLEM of the International Space Agency will be on the Uniforms of the Crew and on the Ship that takes them there, it will in fact be the many globally who labored and sacrificed that gave the breath of life to the International Space Agency essence of existence that flows through it veins. The ISA is NOT your enemy, it is indeed your best chance to give HOPE to your children, and to their children, on this little blue speck of dust in the Infinite Creation of the Universe, A Little Planet We Call Earth! **Build It!, And They Shall Come!**

Since this letter will have wide global circulation, we know those of power and influence, including Presidents of USA, Russia, China, and other Countries, and Leaders in National Space Agencies & Aerospace Corporations Globally will be made aware of this letter, sooner or later.

We plead, and humbly ask, for your support of this historic and important proposal and effort.

What we propose, can only contribute greatly to present efforts of cooperation, collaboration, and joint efforts globally in the Space Community, and in already proposed International Space Initiatives and Programs, and will contribute greatly to improved international relations.

We also ask that this letter be sent on to Colleagues and Key Space Policy Leaders and Space Agencies & Organizations Globally. We ask for those in positions of Power & Influence to please let this effort have an opportunity to prove itself, before judgment or scorn is cast at our feet. We are working hard for you, and the common interests of the Global Space Community, and indeed for all Humanity of our Planet Earth. We only plead for a fair chance to prove that this historic cause and vision, is a worthy and beneficial enterprise and noble endeavor of our time and era

Our most Sincere Wishes to the Peoples of Earth in this Season of Peace, Happiness, and Celebration. And a Sincere Hope for a Wondrous and Historic New Year, in 2019, and for the International Space Agency proposed and planned efforts in 2020.

**International Space Agency, I.S.A.: Name, Public Identity, Logo, Emblem: Are: U.S.A. Registered ®: Trademark™ & Copyrights ©, 1986-2018, All Rights Are Reserved
United Space Federation, U.S.F.: Scientific & Aerospace - Research & Development / Non-Profit Corporation / Incorporated 1990 / New York State / United States of America**



**INTERNATIONAL SPACE AGENCY – I. S. A. – INTERNATIONAL SPACE ADMINISTRATION
AD-ASTRA – TO THE STARS – IN PEACE FOR ALL MANKIND**

Founded In 1986 - Incorporated In 1990 - Presently Seeking International Treaty And Charter Status

NOTICE: Letter Is Diplomatic & Proprietary, Non-Profit Public Release Authorized, All Use With Respect For Trademark & Copyrights

DY: 28 February 2019 SD: 59 TM: 11:31 PM TY: External CL: CAP CAT: INT PAGE: 6 of 11

INTERNATIONAL SPACE AGENCY PROPOSED OPERATIONS BUDGET – 2020

A) CHIEF EXECUTIVE OFFICER & PERSONAL STAFF	-	ANNUAL	MONTHLY
01) Chief Executive Officer (CEO)	-	\$100,000	\$8334
02) Security & Counterintelligence Officer To The CEO	-	\$52,416	\$4368
03) Executive Secretary & Scheduling Aid To The CEO	-	\$50,400	\$4200
04) Culture & Travel & Events PR Aid To The CEO	-	\$48,384	\$4032
TOTAL A	-	\$251,200	\$20,933
B) CHIEF OF OPERATIONS & OPERATIONS STAFF	-	ANNUAL	MONTHLY
01) Chief Operations Officer (COO)	-	\$52,416	\$4368
02) Director of Government & Diplomatic Affairs – “Chief ISA Ambassador”	-	\$50,400	\$4200
03) Director of National Space Agency Affairs	-	\$48,384	\$4032
04) Director of Aerospace & Commercial/Industrial Affairs	-	\$46,368	\$3864
05) Director of Scientific & Research Institutions Affairs	-	\$44,352	\$3696
06) Director of Academic Institutions & University Affairs	-	\$42,336	\$3528
07) Director of NGO’s & Non-Profits & Societies Affairs	-	\$40,320	\$3360
08) Director of Public Affairs & Outreach	-	\$40,320	\$3360
09) Director of Media Affairs & Press Office	-	\$40,320	\$3360
10) Director of Marketing & Advertising & Merchandising	-	\$40,320	\$3360
11) Director of Legal Affairs & Protocol	-	\$40,320	\$3360
12) Director of Security & Safety	-	\$38,304	\$3192
TOTAL B	-	\$524,160	\$43,680
C) CHIEF OF ADMINISTRATION & ADMINISTRATIVE STAFF	-	ANNUAL	MONTHLY
01) Chief Administrations Officer (CAO)	-	\$36,288	\$3024
02) Director of Office Administration (Office Manager)	-	\$34,272	\$2856
03) Director of Computer Data & IT & Communications	-	\$32,256	\$2688
04) Director of Grants, Donations, Contributions, Funding	-	\$30,240	\$2520
05) Office Data Entry & Files Clerk	-	\$28,224	\$2352
06) Office Accountant & Payroll Clerk	-	\$28,224	\$2352
07) Office Typist & Forms Clerk	-	\$26,208	\$2184
08) Office Public Receptionist	-	\$24,192	\$2016
09) Office Supply Clerk	-	\$22,176	\$1848
10) Office Assistant & General Office Clerk	-	\$20,160	\$1680
TOTAL C	-	\$282,240	\$23,520
D) INTERNATIONAL SPACE ADMINISTRATION PERSONNEL	-	ANNUAL	MONTHLY
01) Director of International Space Administration	-	\$52,416	\$4368
02) Director of International Space Technology R&D Center	-	\$50,400	\$4200
03) Director of International Space Academy & Training	-	\$50,400	\$4200
04) Director of International Space Agency Foundation	-	\$50,400	\$4200
05) Director of International Space Plane Program	-	\$50,400	\$4200
06) Director of Centrifugal Propulsion System Program	-	\$50,400	\$4200
07) Director of International Super Computer Center	-	\$50,400	\$4200
08) Director of International Mars Exploration Program	-	\$50,400	\$4200
09) Director of International Luna Exploration Program	-	\$50,400	\$4200
10) Director of International Earth Orbit Infrastructure	-	\$50,400	\$4200
11) Director of Asteroid/Comet Tracking & Protocol Office	-	\$50,400	\$4200
12) Director of Astronomy & Space Sciences Office	-	\$50,400	\$4200
TOTAL D	-	\$606,816	\$50,568
TOTAL OFFICERS / DIRECTORS / STAFFING BUDGET	-	ANNUAL	MONTHLY
TOTAL A & B & C & D	-	\$1,664,416	\$138,701
E) BUILDINGS & FACILITIES & OPERATIONS BUDGET	-	ANNUAL	MONTHLY
01) Washington, D.C. Office (Crystal City, Alexandria, VA)	-	\$120,000	\$10,000
02) Electric & Water Utilities	-	\$12,000	\$1,000
03) Phone & Communications Utilities	-	\$12,000	\$1,000
04) Internet Services, Websites, and Email	-	\$12,000	\$1,000
05) VIP & Staff Housing Facility	-	\$240,000	\$20,000
06) Office Furniture, Computers, Decorations, Equipment	-	\$100,000	\$8334
07) Office Supplies & Consumables & Printing	-	\$24,000	\$2,000
08) Office Staff Van (Vehicle)	-	\$38,000	\$3166
09) Office Staff Car (Vehicle)	-	\$38,000	\$3166
10) Office VIP Van (Vehicle)	-	\$46,000	\$3833

International Space Agency, I.S.A.: Name, Public Identity, Logo, Emblem: Are U.S.A. Registered ®: Trademark™ & Copyrights ©, 1986-2018, All Rights Are Reserved
United Space Federation, U.S.F.: Scientific & Aerospace - Research & Development / Non-Profit Corporation / Incorporated 1990 / New York State / United States of America



**INTERNATIONAL SPACE AGENCY – I. S. A. – INTERNATIONAL SPACE ADMINISTRATION
AD-ASTRA – TO THE STARS – IN PEACE FOR ALL MANKIND**

Founded In 1986 - Incorporated In 1990 - Presently Seeking International Treaty And Charter Status

NOTICE: Letter Is Diplomatic & Proprietary, Non-Profit Public Release Authorized, All Use With Respect For Trademark & Copyrights

DY: 28 February 2019 SD: 59 TM: 11:31 PM TY: External CL: CAP CAT: INT PAGE: 7 of 11

11) Office VIP Car (Vehicle)	-	\$46,000	\$3833
12) 4 Vehicle's Insurance, Tags, Titles, Fuel, Servicing	-	\$24,000	\$2,000
13) Buildings & Facilities Insurance Budget	-	\$24,000	\$2,000
14) Personnel & VIP Travel, Room & Board Budget	-	\$100,000	\$8334
15) Personnel & Agency Events & Conventions Budget	-	\$100,000	\$8334
16) Personnel & Agency Meetings & Hosting Budget	-	\$100,000	\$8334
17) General Operations & Facilities Budget	-	\$100,000	\$8334
18) General Security & Investigations Operations Budget	-	\$100,000	\$8334
19) Personnel Benefits & Insurance Budget	-	\$100,000	\$8334
20) Advertising (T.V., Radio, Print) Budget	-	\$240,000	\$20,000
21) Marketing & Name Recognition & Outreach Budget	-	\$120,000	\$10,000
22) International Space Agency Foundation (ISA Society's)	-	\$100,000	\$8334
23) Technology Research & Development Budget	-	\$240,000	\$20,000
24) Scientific Research & Projects Budget	-	\$120,000	\$10,000
25) International Space News Journal / Magazine Startup	-	\$100,000	\$8334
26) International Space Academy & Training Operations	-	\$240,000	\$20,000
27) International Space Agency Student Programs Globally	-	\$100,000	\$8334
TOTAL BUILDINGS & FACILITIES & OPERATIONS BUDGET	-	ANNUAL	MONTHLY
TOTAL E	-	\$2,596,000	\$216,333
TOTAL INTERNATIONAL SPACE AGENCY WASHINGTON, D.C. OFFICE BUDGET FOR 2020	-	ANNUAL	MONTHLY
TOTAL A & B & C & D & E	-	\$4,260,416	\$355,034

NOTE: This proposed startup budget for the International Space Agency Diplomatic Office in Washington, D.C. & Proposed Operations for 2020, would consist of: 38 dedicated personnel; 1 office facility; 1 housing and VIP facility; 4 staff and VIP vehicles; 12 specific key Program Initiatives; focused marketing/advertising/outreach objectives globally; focused student outreach programs globally; focused public outreach globally; 3 specific key technology initiatives; focused startup for ISA International Space Academy and Training Programs; focused startup of National ISA Societies Globally through the ISA Foundation; dedicated sponsorship of Academic Papers and Scientific Research; specific outreach and diplomatic endeavors with National Governments & National Space Agencies globally; specific outreach to Aerospace, Commercial, Industrial, Scientific, Academic Communities and Institutions globally; specific networking with NGO's, Non-Profits, Societies globally. If this initiative can be fully funded by Government, Corporate, Academic, Private Grants, Donations and Contributions, it is fully expected that the ISA will not only achieve Global recognition and awareness, but develop & secure broad support for International Science and Technology Jobs and Technology Development in an International Space Exploration Program, which will surely result in the creation of a new "Space Industrial Complex" that will far outstrip and exceed anything presently in the "Military Industrial Complex" by scope, scale, complexity, and capability, with more peaceful and productive results.

Here is the Proposed ISA Meeting Fees & Format & Schedule:

Weekly/Monthly Meeting Assets Required/Proposed:

- 1) **Partitionable Conference & Banquet Hall able to accommodate:**
 - A) 250 to 500 people in classroom desk format facing a main presentation stage and very large video projection screen.
 - B) 500+ people in banquet table format with kitchen staff and facilities able to provide 4 star white glove service and food quality
 - C) Monday Only – Buffet Breakfast – Monday 8AM to 10AM / Buffet Lunch – 1PM to 3PM / White Glove - Served Diner – 7:30PM to 8:30 PM
 - D) Monday Only – 7PM to 10PM *Placement of 20 to 30 musicians orchestra style on a stage in front of a wood dance floor
 - E) Monday Only – 7PM to Midnight *DJ and Sound Board Bay or Station on one side of stage
 - H) Sunday Only – 8AM to 8PM – 1000+ people and display booths (Power & Internet Access) for public conference event set up
- 2) 4 Private meeting rooms able to seat 50 people in class room format facing a main presentation stage & video projection screen
- 3) 1 Private meeting room able to seat 20 people in board room format – video screen & conferencing and internet access capability
- 4) Access to bulk rate monthly and weekly room rates for meeting and event attendees and isa staff and personnel
- 5) Access to restaurant or banquet rooms able to accommodate 50 to 100 people in buffet style service – Tue to Sat / 7PM to 10PM
- 6) Access to box lunch service for afternoon session lunch breaks – Tue to Saturday / 12 Noon to 1PM
- 7) **Dedicated ISA Meeting Staff requirements (\$4,200 Monthly Salary Is Based On 14 Hour Days x \$10 Hr x 30 Days) (26 Key Personnel x \$4,200 Monthly Salaries = \$109,200 Staff Salaries Monthly)**

A) Meeting Project Manger	B) Meeting Project Executive Secretary	C) Meeting Project Head of Security	D) Meeting Project Session & Events Coordinator
E) Meeting Project Attendee Relations Coordinator	F) Meeting Project Staff Photographer	G) Meeting Project Staff Reporter & Event Historian	H) Meeting Project Chief Technical Writer & Editor for all Session Reports
I) Meeting Project Dictation and Written Transcripts Specialist	J) Meeting Project Editor for the Monthly, Weekly, and Daily News letters and Magazine	K) Meeting Project Staff Writer for the Monthly, Weekly, and Daily News letters and Magazine	L) Meeting Project Pamphlet & Promotional Materials Specialist
M) Meeting Project Advertising Specialist	N) Meeting Project Printing, Type Setting, and Document Formatting Specialist	O) Meeting Project Computer Information Technology & Internet Specialist	P) Meeting Project Artist and Computer Graphics Specialist
Q) Meeting Project Video Production Specialist	R) Meeting Project Sound and Audio Specialist	S) Meeting Project Accountant & Payroll Clerk	T) Meeting Project Data Entry & Speed Typing Specialist
U) Meeting Project Public Relations Officer	V) Meeting Project Food & Beverage Coordinator	W) Meeting Project Entertainment Coordinator	X) Meeting Project Sessions & Events Steward
Y) Meeting Project Mail Clerk	Z) Meeting Project Mail Clerk		

Final ISA Meeting Event Publication – Thumb Drive: \$100 / Printed & Bound Color “?” / Printed & Bound Black & White :?”

ISA Event Monthly Magazine – Thumb Drive: \$8 / Printed \$25 (*Are Available On The First Business Day Of The Following Month)

ISA Event Weekly News Letters – Email Only: \$2 / Printed \$8 (*Weekly Updates Available Monday 8AM of the Following Week)

International Space Agency, I.S.A.: Name, Public Identity, Logo, Emblem: Are: U.S.A. Registered ®: Trademark™ & Copyrights ©, 1986-2018, All Rights Are Reserved United Space Federation, U.S.F.: Scientific & Aerospace - Research & Development/ Non-Profit Corporation / Incorporated 1990 / New York State / United States of America



**INTERNATIONAL SPACE AGENCY – I. S. A. – INTERNATIONAL SPACE ADMINISTRATION
AD-ASTRA – TO THE STARS – IN PEACE FOR ALL MANKIND**

Founded In 1986 - Incorporated In 1990 - Presently Seeking International Treaty And Charter Status

NOTICE: Letter Is Diplomatic & Proprietary, Non-Profit Public Release Authorized, All Use With Respect For Trademark & Copyrights

DY: 28 February 2019 SD: 59 TM: 11:31 PM TY: External CL: CAP CAT: INT PAGE: 8 of 11

ISA Daily Updates – Email Only – Email Only: \$.50 / Printed \$1.25 (*Daily Updates Available 8AM on the next day)

Note: Publication and Reporting Fees will be used to hire College Work Study Students As Event Reporters & Publication Staff & Costs

General Registration & Security Badge – Administrative Processing Fee is \$100 Per Person – No Exceptions

Note: The Administrative Processing Fee must be received by the International Space Agency no later than 14 Days “2 weeks” before the first day of scheduled meetings and events. – **No Exceptions**

Note: Administrative Processing Fee will be exclusively used for the production and issuing of meeting identification badges, and contracted security back ground checks and physical armed security services. Because of the Diplomatic and International Scope and Participation by International Diplomatic and Senior Executive Corporate Officials, the International Space Agency Corporation will be requesting support from the United States State Department and FBI in matters of event security and the well being and safety of all meeting participants. This event will not be publicly announced or advertised, and communications regarding this event will be exclusive to invited governments, corporations, institutions, and persons. Finalized meeting schedule and events will not be publicized outside the field of approved participants.

Note: All Event Participants will receive a thumb drive with all event literature, information, meeting schedules.

*A published printed version will be offered to those wanting a physical memory of this historic event, however the cost of this will not be known until a few weeks before the meeting occurs. Approved Advertising will be permitted for this historic publication to offset printing costs to meeting participants and to help fund meeting expenses, but any approved advertising must be Non-Military in Nature, and having to do with Civil Space Exploration Related Endeavors, Companies, or Institutions, and must be in the spirit of the purpose and mission of the International Space Agency meetings. Advertising may be offered in multiple languages, however all information presented in any advertisement must also be presented in English. Advertising will all be offered in full color in the following formats:

\$20,000 - Full Page “2” (Inside Front Cover, 1st Page)

\$18,000 - Full Page “2” (Last Page, Inside Back Cover)

\$9,000 - Half Page “4” (2nd Page, 3rd Page)

\$4,500 - Quarter Page “16” (4th Page, 5th Page, 6th Page, 7th Page)

Last several Pages of International Space Agency meeting publication will list benefactors and donors as follows:

Donation of \$1,000 or more - Business Card Sized Color Ad – If the Ad is Commercial - \$200 Ad Fee Charged

Donation of \$500 or more - Name “Bold In Gold”, Address, Phone Number, Email Address – If Ad is Commercial - \$100 Ad Fee Charged

Donation of \$250 or more - Name “Bold In Blue”, Address, Phone Number, Email Address – If Ad is Commercial - \$50 Ad Fee Charged

Donation of \$100 or more - Name “Bold In Black”, Address, Phone Number, Email Address – If Ad is Commercial - \$25 Ad Fee Charged

Donation of \$50 or more - Name, Address, Phone Number, Email Address – If Ad is Commercial - \$25 Ad Fee Charged

Note: No Media or Media Persons will be invited or allowed to attend any meeting activities do to the Sensitive, Proprietary, Diplomatic, and Classified nature of these Private Meetings. A post meeting press conference will be given by the International Space Agency, with overall general results of the meetings, but specific information about meeting participants and specific proprietary information will not be disclosed.

Note: All Information regarding meeting attendees and meeting sessions activities will be Proprietary and Confidential and will be accessed and known by ONLY approved meeting Representatives and Attendees. Furthermore, all meeting Representatives and Attendees will be required to sign a statement of Non-Disclosure in order to attend or participate in these Private ISA Meetings. This is being done, as the sensitive nature of these ISA meetings, and the wide range of political, ideological, and national polarization in the high technology global aerospace sector will limit any genuine, open, and productive dialog and group think, if these meetings are not conducted in a private and safe environment. During the meetings, Representatives and Attendees will be offered an opportunity to make a public statement at the final ISA Press Conference, IF, and ONLY, when they agree to this IN ADVANCE. This strict policy is NOT being implemented to HIDE anything, but insure that the Representatives and Attendees feel SAFE to OPENLY share ideas, concepts, hopes, and concerns, with out fear of reprisals, slander, or attacks. It is critical for these very important historic ISA meetings to develop a sense of peaceful and positive Unity and a collective consciousness of universal good will by the peoples of Earth, therefore it is our main goal to provide a safe and private place for those Representatives and attendees coming to openly participate in these historic ISA meetings.

Note: Primary Representative is a person who is the official spokesperson on behalf of a Government, Corporation, or Institution.

Note: Additional Representatives are persons officially attending from a Government, Corporation, or Institution that are not the Primary Representative. Additional Representatives may upon the appointment of the Primary Representative attend a session event on the behalf of the Primary Representative, Except for mandatory Monday Preamble Ceremonies, which all Primary Representatives must attend.

Note: Legitimate Support Personnel are people who are employed by a Primary Representative or Additional Representative that need legitimate and approved access to the meeting event & sessions for official business in support of the functions of a Primary Representative or Additional Representative, such as Executive Administrative and Security Personnel. Such support personnel must be justified to the ISA Staff, and approved by the Meeting Chief of Security.

Diplomatic Personnel Attending on the behalf of Embassies or National Governments

General Registration & Security Badge – Administrative Processing Fee is \$100 Per Person – No Exceptions

\$500 Per Primary Representative / **\$350** Per Additional Representatives / **\$250** For Legitimate Support Personnel

Legitimate Body Guards or Security Personnel will have no meeting fees, but will still be required to pay the **\$100** Administrative Processing Fee – **No Exceptions** (Note: unless specific need for armed security protection in addition to armed security that will already be provided for these events can be justified and/or approved by the FBI, such additional armed Security will not be authorized.)

Corporate Executive Personnel Attending on behalf of Corporations, Academic or Scientific or Private Institutions

General Registration & Security Badge – Administrative Processing Fee is \$100 Per Person – No Exceptions

\$400 Per Primary Representative / **\$250** Per Additional Representatives / **\$150** For Legitimate Support Personnel

Legitimate Body Guards or Security Personnel will have no meeting fees, but will still be required to pay the **\$100** Administrative Processing Fee – **No Exceptions** (Note: unless specific need for armed security protection in addition to armed security that will already be provided for these events can be justified and/or approved by the FBI, such additional armed Security will not be authorized.)

Private Persons Of Influence Not Representing Government or Corporate Entities, Approved For Participation

General Registration & Security Badge – Administrative Processing Fee is \$100 Per Person – No Exceptions

\$300 Per Primary Representative / **\$150** Per Additional Representatives / **\$50** For Legitimate Support Personnel

Legitimate Body Guards or Security Personnel will have no meeting fees, but will still be required to pay the **\$100** Administrative Processing Fee – **No Exceptions** (Note: unless specific need for armed security protection in addition to armed security that will already be provided for these events can be justified and/or approved by the FBI, such additional armed Security will not be authorized.)

**International Space Agency, I.S.A.: Name, Public Identity, Logo, Emblem: Are: U.S.A. Registered ®: Trademark™ & Copyrights ©, 1986-2018, All Rights Are Reserved
United Space Federation, U.S.F.: Scientific & Aerospace - Research & Development / Non-Profit Corporation / Incorporated 1990 / New York State / United States of America**



INTERNATIONAL SPACE AGENCY – I. S. A. – INTERNATIONAL SPACE ADMINISTRATION
AD-ASTRA – TO THE STARS – IN PEACE FOR ALL MANKIND

Founded In 1986 - Incorporated In 1990 - Presently Seeking International Treaty And Charter Status

NOTICE: Letter Is Diplomatic & Proprietary, Non-Profit Public Release Authorized, All Use With Respect For Trademark & Copyrights

DY: 28 February 2019 SD: 59 TM: 11:31 PM TY: External CL: CAP CAT: INT PAGE: 9 of 11

Academics, Students, Private Citizens, Approved For Participation

General Registration & Security Badge – Administrative Processing Fee is **\$100** Per Person – **No Exceptions**

\$150 Per Primary Representative / **\$100** Per Additional Representatives / **\$50** For Legitimate Support Personnel

W1- Week One Schedule - International Space Agency (ISA) Charter “Constitution” & Treaty Infrastructure

International Space Agency – Draft Charter and Report Regarding Identified Benefits & Detractors and Key Suggestions & Concerns

International Space Agency – 2020 Proposed Washington, D.C. Office & Staffing Budget & ISA Member Nations & Organizations

W2 – Week Two Schedule - ISA “Key” Gateway Program 1 – International Space Operations Center (I.S.O.C.)

International Space Agency – International Space Plane Program & International Electromagnetic Assisted Space Launch System

W3 – Week Three Schedule - ISA “Key” Gateway Programs 2 & 3

International Space Agency – International Earth Orbital Infrastructure (I.E.O.I.) –&- International Space Station (I.S.S.) Program

W4 – Week Four Schedule - ISA “Key” Gateway Programs 4 & 5

International Space Agency – International Planet/Moon Launcher/Lander (IPMLL) & International Solar Cruiser (I. S. C.) Program

W5 – Week Five Schedule - ISA “Key” Gateway Programs 6 & 7

International Space Agency – International Luna Exploration (I. L. E.) Program & International Mars Exploration (I. M. E.) Program

Note: W1 - All 5 Weeks will use the same weekly meeting and activities format and schedule as outlined below

W1-Meeting Registration & Badge Clearance – 7AM to 10AM (Pre-Registration Options Will Be Offered)

W1-Monday 8AM to 10AM – Meet & Greet Breakfast – All Approved Attendees Will Be Provided A Buffet Style Breakfast

W1-Monday 10AM to 12 Noon – International Space Agency Preamble Introduction Ceremony & Docudrama Movie Presentation

***This event is mandatory for all Primary Attendees, any Primary Attendee not participating in this event will be unable to participate in working groups, debate sessions, and closed door sessions for this weeks events.**

W1-Monday 12 Noon to 1PM – Introduction and Acknowledgement of Primary Meeting Attendees, Diplomats, and Representatives

***This event is mandatory for all Primary Attendees, any Primary Attendee not participating in this event will be unable to participate in working groups, debate sessions, and closed door sessions for this weeks events.**

W1-Monday 1PM to 3PM – Meet & Greet Lunch – All Approved Attendees Will Be Provided A Buffet Style Lunch

W1-Monday 3PM to 3:05PM – 5 Minute International Space Agency intro video.

W1-Monday 3:05PM to 3:10PM – Admiral, Zor from Planet Uranis from the Federation of the Order of Grumpy Zirconium Wilfer Beasts

*** Humorous funny space alien skit, as an up stage to Admiral Dobson’s address.**

W1-Monday 3:10PM to 3:15PM – International Space Agency Honor Guard enters the stage and sets ISA Flag and red carpet

W1-Monday 3:15PM to 3:20PM – Admiral, Rick R. Dobson, Jr., Founder of International Space Agency will welcome the participants

W1-Monday 3:20PM to 3:30PM – 10 Minute Key Note Address & Presentation

“Secret Honorary Good Will Ambassador and Spokes person for the International Space Agency meetings is unveiled”

W1-Monday 3:30PM to 4:30PM – 12 “5 Minute” Key Note Addresses by key Government & Private Persons, Global Space Community

W1-Monday 4:30PM to 4:35PM – International Space Agency Honor Guard leaves the stage and secures ISA Flag and red carpet

W1-Monday 4:35PM to 4:55PM – 20 Minute International Space Agency video presentation on how the working groups, debate sessions, and closed door sessions will be structured, organized, and conducted, and how the results of these sessions will be recorded and acted on over the entire International Space Agency meeting agenda and Draft Charter Formation process.

W1-Monday 4:55PM to 5PM – Public Affairs Officer for the International Space Agency hands out Participant Meeting Packets for week one events. Overview of weeks events is displayed on the stage video screen. Public Affairs Officer of ISA and event staff volunteers are positioned at information stations along the front of the stage area, and are there to answer any questions the meeting participants may have.

W1-Monday 5PM to 7PM – International Space Agency staff are available for assistance or questions the participants may have or need.

W1-Monday 7PM - Start – Black Tie & Gown – International Space Agency Gallia Fund Raising Diner and Dance

***Open to International Space Agency Meeting Attendees and Invited Guests ONLY! *No Media is allowed!**

7PM to 10PM – Live Orchestra and Talent and Ballroom Dancing

7:30PM to 9:30PM – Food Served – * 4 Star White Glove Served Meal

Main Course: Choice Of: Chicken –or- Salmon –or- Beef –or- Pork –or- Vegetarian*

Side 1: Choice of: Lobster side –or- Shrimp Cocktail –or- Clams on Shell –or- Scallops Side –or- Fruit Bowl

Side 2: Choice of: Baked Potato –or- House Salad –or- Fruit Bowl –or- Mashed Potatoes –or- Steamed Mixed Veggies

Desert: Choice of: Pie:(Apple / Peach / Cherry / Berry) –or- Chocolate Sunday –or- Chocolate Eclair –or- Fruit Bowl –or- Rainbow Sherbet

Drinks: Milk, Hot Tea, Cold Tea, Coffee, Juice: (Cranberry / Orange / Pineapple / Berry), Soda, Bottled Water ***One Free Glass of Diner Wine or Alcoholic Beverage Per Person, Only**

10PM to Midnight – DJ, Paid Bar, and Open Dance Floor

W1-Tuesday 8AM to 10AM – International Space Agency staff are available for assistance or questions the participants may have or need.

W1-Tuesday 10AM to 12 Noon – Open Session 1 – Thinking Out Loud & Think Tank Strategy – Unstructured Group Think

***This event is mandatory for all Primary Attendees**

International Space Agency, I.S.A.: Name, Public Identity, Logo, Emblem: Are: U.S.A. Registered ®: Trademark™ & Copyrights ©, 1986-2018, All Rights Are Reserved
United Space Federation, U.S.F.: Scientific & Aerospace - Research & Development / Non-Profit Corporation / Incorporated 1990 / New York State / United States of America



INTERNATIONAL SPACE AGENCY – I. S. A. – INTERNATIONAL SPACE ADMINISTRATION
AD-ASTRA – TO THE STARS – IN PEACE FOR ALL MANKIND

Founded In 1986 - Incorporated In 1990 - Presently Seeking International Treaty And Charter Status

NOTICE: Letter Is Diplomatic & Proprietary, Non-Profit Public Release Authorized, All Use With Respect For Trademark & Copyrights

DY: 28 February 2019 SD: 59 TM: 11:31 PM TY: External CL: CAP CAT: INT PAGE: 10 of 11

WI-Tuesday 12 Noon to 1PM – Catered Box Lunch & Break – Meet & Greet

WI-Tuesday 1PM to 3PM – Open Session 2 – Thinking Out Loud & Think Tank Strategy – Unstructured Group Think

* This event is mandatory for all Primary Attendees

WI-Tuesday 3PM to 4PM – Break

WI-Tuesday 4PM to 5PM – Open Session 3 – Structured Overview of the results of Session 1 & 2 Finalized & Formatted

WI-Tuesday 5PM to 7PM – Closed Door Session 1 – ISA Staff and Select Invited Persons – Editing of Session 1 & 2 Report

* The final formalized and typed and formatted results will be circulated to all participants the following day.

WI-Tuesday 7PM to 10PM – Diner Buffet and tables and private meeting spaces to facilitate organized debate

WI-Wednesday 8AM to 10 AM – International Space Agency staff are available for assistance or questions the participants may have or need. Open Session 1 & 2 Report is made available to all meeting participants in print, or email.

WI-Wednesday 10AM to 12 Noon – Open Session 4 – Item by Item, Session 1 & 2 report is debated in structured debate.

* This event is mandatory for all Primary Attendees

WI-Wednesday 12 Noon to 1PM – Catered Box Lunch & Break – Meet & Greet

WI-Wednesday 1PM to 3PM – Open Session 5 – Item by Item, Session 1 & 2 report is debated in structured debate.

* This event is mandatory for all Primary Attendees

WI-Wednesday 3PM to 4PM – Break

WI-Wednesday 4PM to 5PM – Open Session 6 – Structured Overview of the results of Session 4 & 5 Finalized & Formatted

WI-Wednesday 5PM to 7PM – Closed Door Session 2 – ISA Staff and Select Invited Persons – Editing of Session 4 & 5 Report

* The final formalized and typed and formatted results will be circulated to all participants the following day.

WI-Wednesday 7PM to 10PM – Diner Buffet and tables and private meeting spaces to facilitate organized debate

WI-Thursday 8AM to 10 AM – International Space Agency staff are available for assistance or questions the participants may have or need. Open Session 4 & 5 Report is made available to all meeting participants in print, or email.

WI-Thursday 10AM to 12 Noon – Open Session 7 – Item by Item, Session 4 & 5 report is debated in structured debate.

* This event is mandatory for all Primary Attendees

WI-Thursday 12 Noon to 1PM – Catered Box Lunch & Break – Meet & Greet

WI-Thursday 1PM to 3PM – Open Session 8 – Item by Item, Session 4 & 5 report is debated in structured debate.

* This event is mandatory for all Primary Attendees

WI-Thursday 3PM to 4PM – Break

WI-Thursday 4PM to 5PM – Open Session 9 – Structured Overview of the results of Session 4 & 5 Finalized & Formatted

WI-Thursday 5PM to 7PM – Closed Door Session 3 – ISA Staff and Select Invited Persons – Editing of Session 4 & 5 Report

* The final formalized and typed and formatted results will be circulated to all participants the following day.

WI-Thursday 7PM to 10PM – (Diner Buffet * 7PM to 8PM) and tables and private meeting spaces to facilitate organized debate

WI-Friday 8AM to 10 AM – International Space Agency staff are available for assistance or questions the participants may have or need. Open Session 4 & 5 Report is made available to all meeting participants in print, or email.

WI-Friday 10AM to 12 Noon – Open Session 10 – Item by Item, Structured Voting of Session 4 & 5 Final Report

* This event is mandatory for all Primary Attendees

WI-Friday 12 Noon to 1PM – Catered Box Lunch & Break – Meet & Greet

WI-Friday 1PM to 3PM – Closed Door Session 4 – Key Appointed Persons and ISA Staff will give an overview and presentation on the final debated results of open session 10. Primary Benefits and Detractors identified are highlighted and focused on. Key suggestions and concerns which were of noteworthy and apparent importance as generally accepted by a majority of Primary Attendees are high lighted and focused on. *This event is mandatory for all Primary Attendees

WI-Friday 3PM to 4PM – Break

WI-Friday 4PM to 5PM – Closed Door Session 5 – Structured Overview of the results of Closed Door Session 4 Finalized & Formatted – Final input and recommendations by invited key Primary Attendees is conducted.

WI-Friday 5PM to 7PM – Closed Door Session 6 – ISA Staff and Select Invited Persons – Editing of Closed Door Session 5 Report and Input, and the Final Draft Charter for the International Space Agency is assembled and edited for final submission to the International Space Agency meeting participants. Also, a debrief final report of Open Sessions 1-10 and Closed Door Sessions 1 to 6 will be finalized and formatted.

* The final formalized and typed and formatted results of Week 1 will be circulated to all participants the following day.

* The Finalized Draft International Space Agency Charter circulated to all participants the following day.

WI-Friday 7PM to 10PM – Diner Buffet and tables and private meeting spaces to facilitate organized debate

International Space Agency, I.S.A.: Name, Public Identity, Logo, Emblem: Are: U.S.A. Registered ®: Trademark™ & Copyrights ©, 1986-2018, All Rights Are Reserved
United Space Federation, U.S.F.: Scientific & Aerospace - Research & Development / Non-Profit Corporation / Incorporated 1990 / New York State / United States of America



INTERNATIONAL SPACE AGENCY – I. S. A. – INTERNATIONAL SPACE ADMINISTRATION
AD-ASTRA – TO THE STARS – IN PEACE FOR ALL MANKIND

Founded In 1986 - Incorporated In 1990 - Presently Seeking International Treaty And Charter Status

NOTICE: Letter Is Diplomatic & Proprietary, Non-Profit Public Release Authorized, All Use With Respect For Trademark & Copyrights

DY: 28 February 2019 SD: 59 TM: 11:31 PM TY: External CL: CAP CAT: INT PAGE: 11 of 11

WI-Saturday 8AM to 10 AM – Breakfast Buffet and tables and private meeting spaces to facilitate organized debate International Space Agency staff are available for assistance or questions the participants may have or need.

WI-Saturday 10AM to 12 Noon – Closed Door Session 7 – Parliamentary Protocol is in effect – A session Chair will be appointed to lead the session. Primary Attendees are given 5 minutes to address the final week 1 report and the Draft Charter of the International Space Agency. They may chose for their comments to be either off the record or for on the record. This is not a debate session, and comments are allowed without interruption or response. If there is time remaining, after all who wish to use their 5 minute comments to be heard, then Session Chair may ask if any wish to speak to further their comments time or to ask a question of another who has spoken. These will also be restricted to 5 minutes or less. *This event is mandatory for all Primary Attendees

WI-Saturday 12 Noon to 1PM – Catered Box Lunch & Break – Meet & Greet

WI-Saturday 1PM to 3PM – Closed Door Session 8 – Parliamentary Protocol is in effect – A session Chair will be appointed to lead the session. Primary Attendees will be given a vote card with a list of key items identified from Week 1:

- 1) 40 Primary Benefits Identified - as was generally accepted by majority of Primary Attendees
- 2) 40 Primary Detractors Identified - as was generally accepted by majority of Primary Attendees
- 3) 40 Key Suggestions Identified - which where of noteworthy & apparent importance as generally accepted by majority of Primary Attendees
- 4) 40 Key Concerns Identified - which where of noteworthy & apparent importance as generally accepted by majority of Primary Attendees

The Chair will ask all those wishing to make their vote "Yes or No or Abstain" public, to stay in their seats. Those wishing to cast their vote but anonymous are to fill out their vote card with no name and bring it forward to be dropped in a locked voting box. The anonymous votes will then be counted in full view of the session attendees and presented on marker boards around the room. The voting cards with no names will then be entered into the record and vote card historic archive. Then the chair will conduct an item by item vote of each item by a show of hands for yes, no, and abstain. As the vote is taken for each item, the marker boards are updated for each item. When the votes are finished, the results will be used to narrow the 40 items each category to 12 key items for each category, that will be used in future activities. The final vote count for all 40 items will be finalized and formatted and provided in a vote summary document and general overview report, and then the 12 top items in each category will then be identified and highlighted for use as a focal point for future negotiations & debate. *This event is mandatory for all Primary Attendees

WI-Saturday 3PM to 4PM – Break

WI-Saturday 4PM to 5PM – Closed Door Session 9 – Structured Overview of the results of Closed Door Session 7 & 8 Finalized & Formatted – Final input and recommendations by invited key Primary Attendees is conducted.

WI-Saturday 5PM to 7PM – Closed Door Session 10 – ISA Staff and Select Invited Persons – Editing of Closed Door Session 7 & 8 is assembled and edited for final submission to the International Space Agency meeting participants. Also, a debrief final report of Open Sessions 1-10 and Closed Door Sessions 1 to 10 will be finalized and formatted for the final Weekly Report.

* The final formalized and typed and formatted results will be circulated to all participants on Monday of the following week.

* The Finalized Draft International Space Agency Charter circulated to all participants on Monday of the following week.

WI-Saturday 7PM to 10PM – Diner Buffet and tables and private meeting spaces to facilitate organized debate

WI-Saturday 6AM to Midnight – Open to Meeting Attendees Only – Demonstrations / Presentations / Displays / White Paper Submissions

BOOTHS: \$700 - Large Booth / \$600 - Medium Booth / \$500 - Small Booth - *All Booths have Power and Internet Access

BAYS: \$400 - 3 Table Bay / \$300 - 2 Table Bay / \$200 - 1 Table Bay - *All Bays have Power and Internet Access

STATIONS: \$100 - 3 Table Station / \$75 - 2 Table Station / \$50 - 1 Table Station - *No Power or Internet Access

*Note: Flyers and Promotional Materials can not be distributed beyond the confines of a Booth, Bay, Or Table Station

\$100 – Approved Not For Profits and Academic & Student Groups with permission to distribute promotional flyers on site

WI-Sunday 6AM to 10PM – Open to Public (\$10 Adults / \$5 Others) – Demonstrations / Presentations / Displays / White Paper Submissions

BOOTHS: \$700 - Large Booth / \$600 - Medium Booth / \$500 - Small Booth - *All Booths have Power and Internet Access

BAYS: \$400 - 3 Table Bay / \$300 - 2 Table Bay / \$200 - 1 Table Bay - *All Bays have Power and Internet Access

STATIONS: \$100 - 3 Table Station / \$75 - 2 Table Station / \$50 - 1 Table Station - *No Power or Internet Access

*Note: Flyers and Promotional Materials can not be distributed beyond the confines of a Booth, Bay, Or Table Station

\$100 – Approved Not For Profits and Academic & Student Groups with permission to distribute promotional flyers on site

End of Transmission – End of Diplomatic Dispatch – End of Communication – End of Letter – End of Proposal

Dear, Esteemed Ladies and Gentlemen, Respectfully, Inclose,

Thank You, for your Precious Time, Serious Consideration, and Support to this most Historic and Important Proposal, Vision, and Endeavor, on the Creation of one of the most important Organizations of our Time and Era.

On behalf of all of my ISA Colleagues & Supporters Globally, and Myself, I wish you our very best regards,

Ad-Astra! To The Stars! In Peace For All Mankind!

Humbly, In Your Service,

Truly, I Am,
Admiral, Rick R. Dobson, Jr.

Founder, Chairman, CEO
International Space Agency, I.S.A.
International Space Administration

“The Space Man”

Signed on 28th of February, 2019



International Space Agency, I.S.A.: Name, Public Identity, Logo, Emblem: Are: U.S.A. Registered ®: Trademark™ & Copyrights ©, 1986-2018, All Rights Are Reserved
United Space Federation, U.S.F.: Scientific & Aerospace - Research & Development / Non-Profit Corporation / Incorporated 1990 / New York State / United States of America